

# SL6200/1200G Gasoline Powered Airless Paint Sprayer

## SERVICE & OPERATION MANUAL



### Specifications:

#### Usage:

**7,500 Gallons per Year**

Large New Residential Projects,  
Medium to Large Commercial Buildings, Industrial Use

#### For Spraying:

Latex - High Solids  
Oil Based Paint  
Stain  
Enamels

Lacquers  
100% Acrylics  
Elastomerics  
Block Fillers

Epoxy  
Mastics  
Dry Fall/Fog

#### Features:

High Torque Clutch - 6 in. diameter  
Stainless Steel "Slow Stroking" Paint Pump  
High Pressure Filter  
Triple Life Packings

#### Performance:

##### Spray Tip Size

**1 Gun up to 0.041 in.**

**2 Guns up to 0.028 in.**

##### Pressure Flow

**1.5 GPM      5.7 Ltr/Min.**

Free Flow

1.6 GPM      6.1 Ltr/Min.

Engine 5.5 HP Honda - Overhead Cam - Oil Alert

Weight-LoBoy/HiBoy 134/144 Lbs 61/65 Kgs

Hose Length up to 300 Feet 91 Meters



**BUILT TO PERFORM...**  
**BUILT TO LAST**

# TABLE OF CONTENTS

Introduction	3
Flushing	3
How to Flush	4
Setting Up	5
Starting Up	5 & 6
Warnings	6,7,8 & 9
PRESSURE RELIEF PROCEDURE	8
Spray Technique	10 & 11
Airless Spray Gun Operation	12
REV-TIP™ Selection Chart	13
Regular Maintenance	14
Oil and Lubrication	14
Field Troubleshooting	14 & 15
Servicing Fluid Pump	15
Servicing Inlet and Outlet Valves	16
V-Packing Replacement	17, 18
Ball Valve	19
Troubleshooting - Clutch	19
Replacement of Electrical Control Board	20
Pressure Calibration of Elec. Board	20
Clutch Replacement - Hi-Boy	21
Clutch Replacement - Lo-Boy	22, 23
Clutch Assembly Parts Lists	23
Engine Assembly Parts Lists	24
Paint System Assembly Parts List- Hi-Boy	25
Paint System Assembly Parts List- Lo-Boy	26
Manifold Filter	27
Complete Sprayer Parts List - Hi-Boy	28 & 29
Power Unit Assembly - Lo-Boy	30
Frame Assembly -Lo-Boy	31
Suction Assembly	31
Accessories	32



Manufactured by: AIRLESSCO BY DUROTECH CO.  
P.O.BOX 8006, MOORPARK, CA. 93020-8006  
SHIP TO: 5397 COMMERCE AVE. MOORPARK, CA. 93021  
TELEPHONE: 805-523-0211 FAX: 805-523-1063

Copyright 2003, All rights reserved. Subject to change without notice.

# INTRODUCTION

This gas powered airless sprayer is built tough to take the day after day high volume demands of contractors. The paint pump features a large stainless steel, severe duty, slow-stroking piston, and Airlessco's patented stationary triple-life packing. This product is "**Built to Perform...Built to Last**" using the latest technology in pump design for smooth operation and low maintenance.

## SPECIFICATIONS AIRLESSCO SL6200, ALLPRO 1200G

<i>Pressure</i>	0 - 3000 psi
<i>Output</i>	1.5 gpm, 5.7 Ltr./Min.
<i>Tip size</i>	1 gun up to 0.041" 2 guns up to 0.028"
<i>Engine</i>	5.5 hp Honda

## IMPORTANT WARNING !!



**HANDLE THIS UNIT AS YOU WOULD A LOADED FIREARM!  
High Pressure Spray Can Cause Extremely Serious Injury.  
OBSERVE ALL WARNINGS!**

Before operating this unit, read and follow all safety warnings and instructions related to the usage of this equipment. **READ** and **LEARN** the warnings on pages 4, 5, 6, & 7 and **FOLLOW** the Pressure Relief Procedure on Page 6.

All Service Procedures to be performed by an Authorized Airlessco Service Center ONLY.  
NO MODIFICATIONS or alterations of any AIRLESSCO Equipment or part is allowed.

## FLUSHING - Read Prior to Using Your Sprayer

### 1. New sprayer

Your unit was factory tested in an anti-freeze solution which was left in the pump. Before using oil-base paint, flush with mineral spirits only. Before using water-base paint flush with mineral spirits, followed by soapy water, then a clean water flush.

### 2. Changing colors

Flush with a compatible solvent such as mineral spirits or water.

### 3. Changing from water-base to oil-base paint

Flush with soapy water, then mineral spirits.

### 4. Changing from oil-base to water-base paint.

Flush with mineral spirits, followed by soapy water, then a clean water flush.

### 5. Storage

Oil-base paint: Flush with mineral spirits.

Water-base paint: Flush with water, then mineral spirits and leave the pump, hose and gun filled with mineral spirits.

For longer storage, use mixture of mineral spirits and motor oil (half & half). Shut off the sprayer, follow Pressure Relief Procedure on page 6 to relieve pressure and make sure prime valve is left open.

### 6. Start up after storage

Before using water-base paint, flush with soapy water and then a clean water flush.

When using oil-base paint, flush out the mineral spirits with the material to be sprayed.

# HOW TO FLUSH

FIG. 1

REMOVE  
SPRAY  
TIP

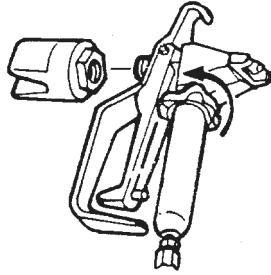

FIG. 2

PRESSURE CONTROL  
KNOB



PRIME VALVE &  
PRESSURE RELIEF  
VALVE

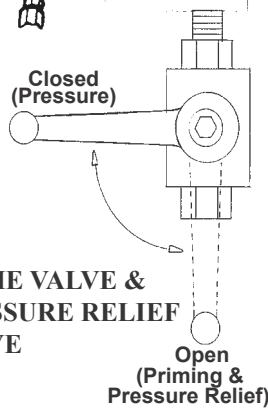

FIG. 3

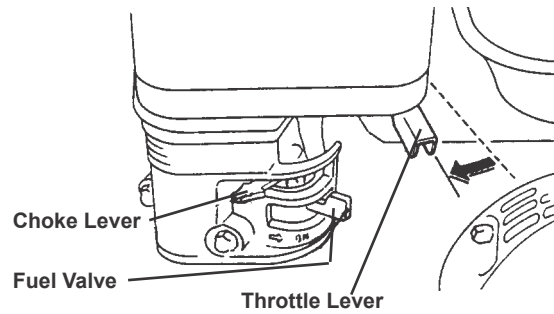

FIG. 4

MAINTAIN FIRM  
METAL TO METAL  
CONTACT BETWEEN  
GUN AND CONTAINER



1. Be sure the gun safety latch is engaged and there is no spray tip in the gun. Refer to Fig. 1. Refer to your separate instruction manual provided with your gun on its safety features and how to engage safety latch.
2. Pour enough clean, compatible solvent into a large, empty metal pail to fill the pump and hoses.
3. Place the suction tube into the pail or place the pail under the pump.
4. Turn the pressure control knob to low pressure. Refer to Fig. 2.
5. Open the prime valve to the open - "Priming Position". This will allow an easy start. Refer to Fig. 2.
6. Turn the engine ON/OFF switch to ON.
7. Move the choke toward the closed position as per Fig.3.
8. Move the throttle lever slightly to the left as per Fig.3.
9. Turn the fuel valve ON as per Fig. 3. Pull the start rope. Pull the engine over against compression stroke and then let the rope rewind slowly into the starter. Pull firmly and rapidly to start the engine. Do NOT drop the rope. Hold on to the handle while rewinding, or the rope may rewind improperly and jam the assembly. If the engine does not start, open the choke a little more. If the engine floods, open the choke all the way and continue cranking.
10. After the engine is warm, gradually close the choke lever, increase the RPM of engine slightly by moving throttle to the left. Close the prime valve. Refer to Fig. 2
11. Point the gun into the metal pail and hold a metal part of the gun firmly against the pail Refer to fig. 4

**WARNING: To reduce the risk of static sparking, which can cause fire or explosion, always hold a metal part of the gun firmly against the metal pail when flushing. This also reduces splashing. Refer to Fig.4.**

12. Disengage the gun safety latch and squeeze the gun trigger. At the same time, slowly turn the pressure control knob clockwise just enough to move liquid at low pressure.
13. Allow the pump to operate until clean solvent comes from the gun.
14. Release the trigger and engage the gun safety latch.
15. If you are going to start spraying, place the pump or suction tube into the supply container. Release the gun safety latch and trigger the gun into another empty, metal container, holding a metal part of the gun firmly against the metal pail (Fig. 4), forcing the solvent from the pump and hose. When paint starts coming from gun, turn pressure control knob to minimum pressure, place prime valve in prime (open) position and engage the gun safety latch.
16. If you are going to store the sprayer, remove the suction tube or pump from the solvent pail force the solvent from the pump and hose. Engage the gun safety latch and refer to the "Storage" Procedure on page 1. Step 5.
17. Whenever you shut off the sprayer follow the Pressure Relief Procedure warning on page 8.

# SETTING UP

## 1. Connect the hose and gun

- Remove the plastic cap plug from the outlet and screw a conductive or grounded 3000 psi spray hose onto fluid outlet.
- Connect an airless spray gun to the other end of the hose, but do not install the spray tip yet!

**NOTE:** Do not use thread sealer on swivel unions as they are made to self seal.

**NOTE:** The first 50' of hose should always be 3/8".

## 2. Fill the Packing Nut/Wet Cup

Fill the Packing Nut/Wet Cup 1/3 full with Airlessco Throat Seal Oil (TSO). Fig 5 below.

**FIG. 5**

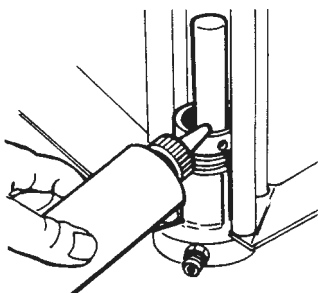

## 3. Check the Engine Oil Level

- Unscrew the oil fill plug. The dipstick is attached to the plug.
- Without threading the plug into place, check to be sure the oil is up to the top mark on the dipstick.
- If oil is needed, refer to engine manual.

## 4. Fill the Fuel Tank

**WARNING:** Fuel spilled on a hot surface can cause a fire or explosion and cause serious bodily injury and property damage. Always shut off the engine and let it cool before filling the tank, and carefully follow steps a - c below being sure not to spill any fuel.

- Close the fuel shutoff valve.
- Use only clean, fresh, well-known brands of unleaded regular grade gasoline.
- Remove the fuel cap and fill tank. Be sure the air vent in the fill cap is not plugged so fuel can flow to the carburetor, then replace the cap.

# STARTING UP

## 1. Learn the controls

**Pressure Control Knob** - used to adjust pressure only. Turn clockwise to increase pressure and counter-clockwise to decrease pressure. (See Fig. 6)

**Prime & Pressure Relief Valve** - Turn to OPEN position (see Fig. 7) to prime the pump. Turn to the CLOSED position to spray.

**FOLLOW "PRESSURE RELIEF PROCEDURES" ON PAGE 6 WHENEVER YOU:**

- are instructed to relieve pressure
- stop spraying
- checking or servicing any of the system equipment.
- or installing or cleaning the spray tip.

Handle spray system as you would a loaded firearm!

**CAUTION:** Do not start engine without fluid pump having enough fluid so that it can be primed. Running fluid pump dry will decrease life of the pumps packings.

## 2. Prepare the Material

- Prepare the material according to the material manufacturer's recommendations.
- Place pump or suction tube into material container.

**FIG. 6**

**PRESSURE CONTROL KNOB**

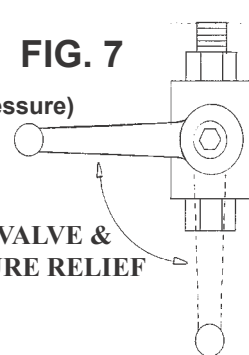

**FIG. 7**

**Closed (Pressure)**

**PRIME VALVE & PRESSURE RELIEF VALVE**

**Open (Priming & Pressure Relief)**



## 3. Starting the Sprayer (see Fig. 6 & 7 above)

- Prime Valve must be open - priming position.
- Pressure Control Knob must be in low pressure.
- Follow the procedure under "How to Flush", page 4 Steps 6 through 12.

**WARNING:** To stop the unit in an emergency or before performing any service or maintenance procedure follow the Pressure Relief Procedure on page 6 to relieve the fluid pressure.

# STARTING UP - continued

## 4. Prime the Pump

- Allow pump to operate until paint comes from gun.
- Release the trigger and engage the gun safety latch.
- Turn Prime Valve OPEN to the prime position ensuring the pressure is released from the system.
- Turn Pressure Control Knob to minimum pressure.
- Install spray tip onto gun.
- Close the prime valve to the pressure position.
- Turn the pressure control knob to desired spray pressure.
- Disengage the gun safety lock and you are ready to start spraying.

**WARNING: If you spray into the paint bucket, always use the lowest spray pressure and maintain firm metal to metal contact between gun and container. See page 6, Fig 4.**

## 5. Adjusting the Pressure

- Turn the Pressure Control Knob clockwise to increase pressure and counterclockwise to decrease pressure.
- Always use the lowest pressure necessary to completely atomize the material.

**CAUTION - Operating the sprayer at higher pressure than needed wastes material, causes early tip wear and shortens sprayer life.**

- If more coverage is needed use a larger tip rather than increasing the pressure.
- Check the spray pattern. The tip size and angle determines the pattern width and flow rate.

## 6. Reducing Clutch Wear

- The first 50 feet of airless spray hose should be 3/8", the larger diameter works as a pulsation damper and saves unnecessary cycling of the clutch. A minimum of 100 feet of hose should be used.
- Adjust the Engine Speed and Pump Pressure. First set the throttle lever to the maximum RPM setting (fully left). Trigger the gun onto a test paper to check the spray pattern and atomization. Adjust the Pressure Control Knob until you get a good pattern. Reduce RPM of engine to support pressure without laboring engines.

## 7. Cleaning a Clogged Tip

### IMPORTANT WARNING

Always follow the Pressure Relief Procedure on page 8 before performing any service or maintenance procedure.

**WARNING:** Never hold your body, fingers, or hand in a rag in front of the spray tip when cleaning or checking it for a cleared tip. Always point the gun toward the front or into a waste container when checking to see if the tip is cleared or when using a self-cleaning tip.

- Follow the Pressure Relief Procedure on page 8.
- Clean the front of the tip frequently (with toothbrush only) during the day to keep material from building up and clogging the tip.
- To clean and clear a tip if it clogs, refer to the separate instruction manual received with your gun and nozzle. *There is an easy way to keep the outside of the tip clean from material build-up:*

*Every time you stop spraying, for even a minute, lock the gun and submerge the gun into a small bucket of thinner comparable with the material sprayed. Thinner will dissolve the build up of paint on the outside of tip, tip guard and gun much more effectively than if the paint dries out completely.*

**WARNING: Clogged standard flat tip - clean only after the tip is removed from the gun. Follow the Pressure Relief Procedure Warning on Page 6.**

## 8. When Shutting Off the Sprayer

- Whenever stop spraying, even for a short break, follow the Pressure Relief Procedure Warning on page 6.
- Clean the tip and gun as recommended by your separate gun instruction manual.
- Flush the sprayer at the end of each work day if the material you are spraying is waterbased, or if it could harden in the sprayer overnight. See "Flushing" page 1 and 2. Use a compatible solvent to flush, then fill the pump and hoses with an oil based solvent such as mineral spirits.
- For long term shutdown or storage, refer to page 1.

**WARNING - Be sure to relieve pressure in the pump after filling with mineral spirits.**

# WARNINGS

## MEDICAL ALERT - Airless Spray Wounds

*If any fluid appears to penetrate your skin, get **EMERGENCY MEDICAL CARE AT ONCE. DO NOT TREAT AS A SIMPLE CUT.** Tell the doctor exactly what fluid was injected. Have him read*

**NOTE TO PHYSICIAN:** *Injection in the skin is a traumatic injury. It is important to treat the injury surgically as soon as possible. DO NOT DELAY treatment to research toxicity. Toxicity is a concern with some exotic coatings injected directly into the blood stream. Consultation with a plastic surgeon or reconstructive hand surgeon may be advisable.*

# WARNINGS

## HIGH PRESSURE SPRAY CAN CAUSE EXTREMELY SERIOUS INJURY. OBSERVE ALL WARNINGS. THIS SPRAYER IS FOR PROFESSIONAL USE ONLY.

### INJECTION HAZARD

Fluids under high pressure from spray or leaks can penetrate the skin and cause extremely serious injury, including the need for amputation.

NEVER point the spray gun at anyone or any part of the body.

NEVER put hand or fingers over the spray tip. Do not use rag or other materials over your fingers. Paint will penetrate through material and into the hand.

NEVER try to stop or deflect leaks with your hand or body.

ALWAYS have gun tip guard in place when spraying.

ALWAYS lock gun trigger when you stop spraying.

ALWAYS remove tip from the gun to clean it.

NEVER try to "blow back" paint, this is not an air spray sprayer.

ALWAYS follow the **PRESSURE RELIEF PROCEDURE**, as shown on page 8, before cleaning or removing the spray tip or servicing any system equipment.

Be sure equipment safety devices are operating properly before each use.

Tighten all fluid connections before each use.

### MEDICAL TREATMENT

If any fluid appears to penetrate your skin, get EMERGENCY CARE AT ONCE. DO NOT TREAT AS A SIMPLE CUT.

\* Go to an emergency room immediately.

\* Tell the doctor you suspect an injection injury.

\* Tell him what kind of material you were spraying with and have him read NOTE TO PHYSICIAN on pg. 6.

### GENERAL PRECAUTION

NEVER alter equipment in any manner.

NEVER smoke while in spraying area.

NEVER spray highly flammable materials.

NEVER use around children.

NEVER allow another person to use sprayer unless he is thoroughly instructed on its' safe use and given this operators manual to read.

ALWAYS wear a spray mask, gloves and protective eye wear while spraying.

ALWAYS ensure fire extinguishing equipment is readily available and properly maintained.

**NEVER LEAVE SPRAYER UNATTENDED WITH PRESSURE IN THE SYSTEM. FOLLOW PRESSURE RELIEF PROCEDURES ON PAGE 6.**

### TOXIC FLUID HAZARD

Hazardous fluid or toxic fumes can cause serious injury or death if splashed in eyes or on skin, inhaled or swallowed. Know the hazards of the fluid you are using. Store & dispose of hazardous fluids according to manufacturer, local, state & national guidelines.

ALWAYS wear protective eyewear, gloves, clothing and respirator as recommended by fluid manufacturer.

### ALWAYS INSPECT SPRAYING AREA

Keep spraying area free from obstructions.

Make sure area has good ventilation to safely remove vapors and mists.

NEVER keep flammable material in spraying area.

NEVER spray in vicinity of open flame or other sources of ignition.

Spraying area must be at least 20 ft. away from spray unit.

### SPRAY GUN SAFETY

ALWAYS set safety lock on the gun in "LOCKED" position when not in use and before servicing or cleaning.

DO NOT remove or modify any part of gun.

ALWAYS REMOVE SPRAY TIP when cleaning. Flush unit with LOWEST POSSIBLE PRESSURE.

CHECK operation of all gun safety devices before each use.

Be very careful when removing the spray tip or hose from gun. A plugged line contains fluid under pressure. If the tip or line is plugged, follow the PRESSURE RELIEF PROCEDURE as outlined on page 6.

### TIP GUARD

ALWAYS have the tip guard in place on the spray gun while spraying. The tip guard alerts you to the injection hazard and helps prevent accidentally placing your fingers or any part of your body close to the spray tip.

### SPRAY TIP SAFETY

Use extreme caution when cleaning or changing spray tips. If the spray tip clogs while spraying, engage the gun safety latch immediately. ALWAYS follow the PRESSURE RELIEF PROCEDURE before removing the spray tip to clean it.

NEVER wipe off build up around the spray tip.

ALWAYS remove tip & tip guard to clean AFTER pump is turned off and the pressure is relieved by following the PRESSURE RELIEF PROCEDURE.

### KEEP CLEAR OF MOVING PARTS

Keep clear of moving parts when starting or operating the sprayer. Do not put your fingers into any openings to avoid amputation by moving parts or burns on hot parts. Precaution is the best insurance against an accident.

When starting the engine, maintain a safe distance from moving parts of the equipment.

Before adjusting or servicing any mechanical part of the sprayer, follow the PRESSURE RELIEF PROCEDURE on page 6, and remove the ignition cable from the spark plug to prevent accidental starting of sprayer.

WARNINGS CONTINUED ON NEXT PAGE.....

# WARNINGS - Continued

## PRESSURE RELIEF PROCEDURE

To avoid possible serious bodily injury, including injection, always follow this procedure whenever the sprayer is shut off, when checking or servicing it, when installing or changing the tips, whenever you stop spraying or when you are instructed to relieve the pressure.

1. Engage gun safety latch. Refer to separate instruction manual provided with your gun on its safety features and how to engage safety latch.



2. Turn engine off.

3. Disengage safety latch & trigger gun to relieve residual fluid pressure. Hold metal part of the gun in contact with grounded metal pail.



4. Re-engage gun safety latch



5. Turn Prime/Pressure Relief Valve as shown open (priming) to relieve fluid pressure.

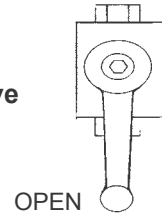

Leave prime valve OPEN until you are ready to spray again.

**IF THE SPRAY TIP OR HOSE IS CLOGGED, follow Step 1 through 5 above. Expect paint splashing into the bucket while relieving pressure during Step 5. If you suspect that pressure hasn't been relieved due to damaged prime/pressure relief valve or other reason, engage gun safety latch and take your sprayer to an authorized Airlessco Service Center for service.**

Always follow recommended pressure & operating instructions:

### HOSES

Tighten all fluid connections securely before each use. High pressure fluid can dislodge a loose coupling or allow high pressure spray to be emitted from the coupling and result in an injection injury or serious bodily injury.

Use only hose that has a spring guard. The spring guard helps protect the hose from kinks or other damage which could result in hose rupture and cause an injection injury.

NEVER use a damaged hose, which can result in hose failure or rupture and cause in injection injury or other serious bodily injury or bodily damage. Before each use, check entire hose for cuts, leaks, abrasion or bulging of cover, or damage or movement of couplings. If any of these conditions exist, replace the hose immediately. Never use tape or any device to try to mend the hose as it cannot contain the high pressure fluid. NEVER ATTEMPT TO RECOUPLE THE HOSE. High pressure hose is not recoupleable.

Help prevent damage to the hose by handling and routing carefully. Do not move the sprayer by pulling it with the hose.

### LABELING

Keep all labels on the unit clean and readable. Replacement labels are available from manufacturer.

### GROUNDING

Ground the sprayer and other components in the system to reduce the risk of static sparking, fire or explosion which can result in serious bodily injury and property damage.

Always ground all of these components:

1. Sprayer: Connect a ground wire and clamp (supplied) to a true earth ground.
2. Fluid Hose: use only grounded hoses.
3. Spray gun or dispensing valve: grounding is obtained through connection to a properly grounded fluid hose and pump.
4. Object being sprayed: according to your local code.
5. All solvent pails used when flushing should only be metal pails which are conductive.

Once each week, check electrical resistance of hose (when using multiple hose assemblies, check overall resistance of unpressurized hose must not exceed 29 megohms (max) for any coupled length or combination of hose lengths. If hose exceeds these limits, replace it immediately.

Never exceed 500 Ft. (150 m.) overall combined hose length to assure electrical continuity.

**NOTE: WARNINGS CONTINUE ON NEXT PAGE.**



# WARNINGS - Continued

## AVOID COMPONENT RUPTURE

This sprayer operates at 3000 psi (205 bar). Always be sure that all components and accessories have a maximum working pressure of at least 3000 psi to avoid rupture which can result in serious bodily injury including injection and property damage.

NEVER leave a pressurized sprayer unattended to avoid accidental operation of it which could result in serious bodily injury.

ALWAYS follow the PRESSURE RELIEF PROCEDURE whenever you stop spraying and before adjusting, removing or repairing any part of the sprayer.

NEVER alter or modify any part of the equipment to avoid possible component rupture which could result in serious bodily injury and property damage.

NEVER use weak or damaged or non-conductive paint hose. Do not allow kinking or crushing of hoses or allow it to vibrate against rough or sharp or hot surfaces. Before each use, check hoses for damage and wear and ensure all fluid connections are secure.

REPLACE any damaged hose. NEVER use tape or any device to mend the hose.

NEVER attempt to stop any leakage in the line or fittings with your hand or any part of the body. Turn off the unit and release pressure by following PRESSURE RELIEF PROCEDURE.

ALWAYS use approved high pressure fittings and replacement parts.

ALWAYS ensure fire extinguishing equipment is readily available and properly maintained.

### **WARNING**

**Do not use halogenated solvents in this system. The prime valve, 2 gun manifold and most airless guns have aluminum parts and may explode. Cleaning agents, coatings, paints or adhesives may contain halogenated hydrocarbon solvents. DON'T TAKE CHANCES! Consult your material suppliers to be sure. Some of the most common of these solvents are: Carbontetrachloride, Chlorobenzene, Dichloroethane, Dichloroethyl Ether, Ethylbromide, Ethylchloride, Tetrachloroethane. Alternate valves and guns are available if you need to use these solvents.**

## PREVENT STATIC SPARKED FIRE/ EXPLOSIONS

ALWAYS be sure all equipment and objects being sprayed are properly grounded. Always ground sprayer, paint bucket and object being sprayed. See "grounding" on page 8 for detailed grounding information.

Vapors created when spraying can be ignited by sparks. To reduce the risk of fire, always locate the sprayer at least 20 feet (6 m.) away from the spray area. Do not plug in or unplug any electrical cords in the spray area, which can create sparks, when there is any chance of igniting vapors still in the air. Follow the coating & solvent manufacturers safety warnings and precautions.

Use only conductive fluid hoses for airless applications. Be sure gun is grounded through hose connections. Check ground continuity in hose & equipment. Overall (end to end) resistance of unpressurized hose must not exceed 29 megohms for any coupled length or combination of hose length. Use only high pressure airless hoses with static wire approved for 3000 psi.

### **FLUSHING**

Reduce the risk of injection injury, static sparking or splashing by following the specific cleaning procedure on page 4 and 9.

ALWAYS follow the PRESSURE RELIEF PROCEDURE on page 8.

ALWAYS remove the spray tip before flushing. Hold a metal part of the gun firmly to the side of a metal pail and use the lowest possible fluid pressure during flushing.

NEVER use cleaning solvents with flash points below 140 degrees F. Some of these are: acetone, benzene, ether, gasoline, naphtha. Consult your supplier to be sure.

## GAS ENGINE PRECAUTIONS

Locate unit 25 feet away from spray area in well ventilated area. NEVER operate in closed building unless exhaust is piped outside. NEVER allow hose to lay against engine mufflers or hot parts. NEVER refill fuel tank while engine is hot or is running.

**Important: United States Government safety standards have been adopted under the Occupational Safety & Health Act. These standards, particularly the General Standards, Part 1910, & the Construction Standards, part 1926 should be consulted.**

## WHEN SPRAYING & CLEANING WITH FLAMMABLE PAINTS OR THINNERS:

1. When spraying with flammable liquids, the unit must be located a minimum of 25 feet away from the spraying area in a well ventilated area. Ventilation must be sufficient enough to prevent the accumulation of vapors.
2. To eliminate electrostatic discharge, ground the spray unit, paint bucket and spraying object. Use only high pressure airless hoses approved for 3000 psi which is conductive.
3. Remove spray tip before cleaning gun and hose. Make contact of gun with bucket and spray without the tip in a well ventilated area, into the grounded steel bucket.
4. Never use high pressure in the cleaning process. USE MINIMUM PRESSURE.
5. Do not smoke in spraying/cleaning area.

# SPRAY TECHNIQUE

Good Spray Gun Technique is at the core of any spray paint operation. Operator skill and efficiency is as important as good equipment and good paint. Good spray technique is a skill that can be quickly learned by following these simple instructions.

If you are not familiar with spraying techniques, we recommend that you study this section of your manual and practice the proper technique on pieces of cardboard or a suitable surface.

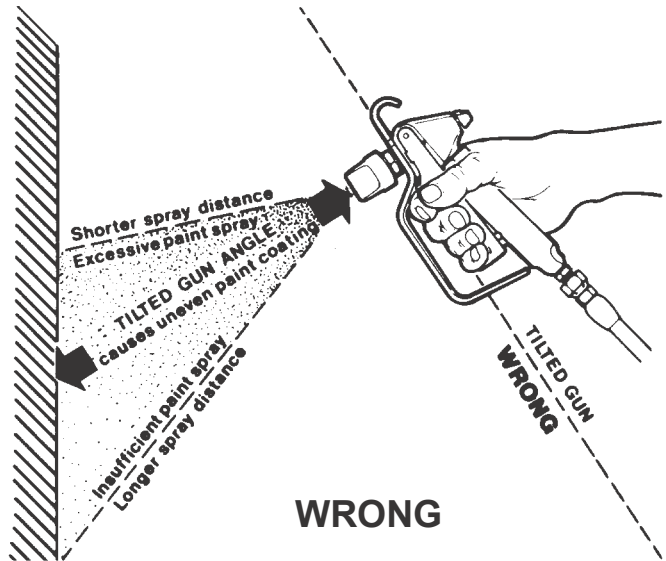
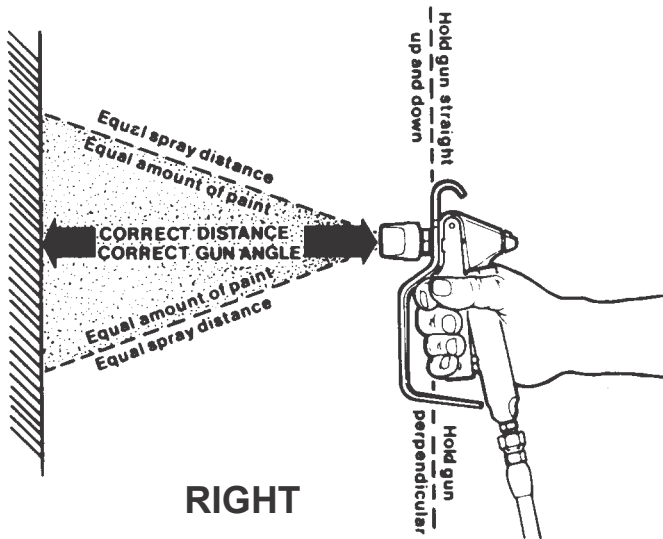

Hold the spray gun 12 - 15 inches away from the work surface and keep it perpendicular (straight) to the surface. Move the spray gun parallel to the work and at a right angle to the surface.

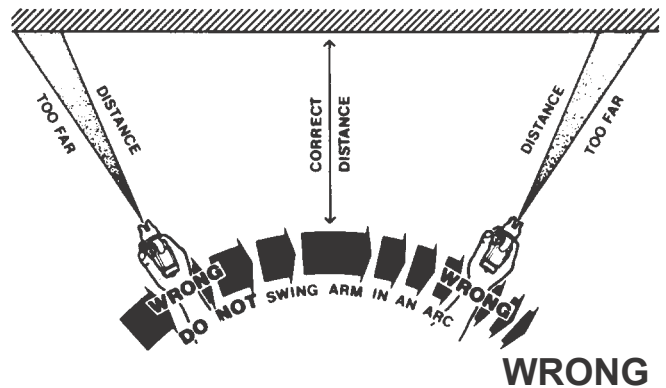
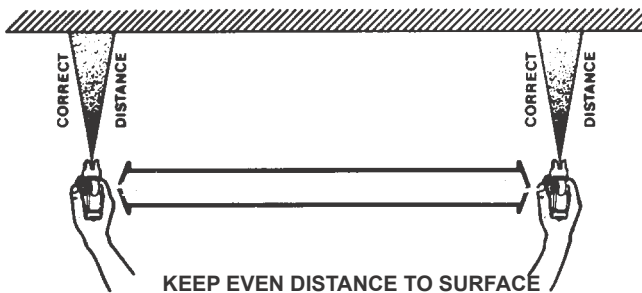

Move the gun at a steady rate in order to apply a good coverage. The wet coat should be just under the thickness at which a run or sag will occur. slow gun movement or gun held too close will result in an overly wet or thick wet or thick coat coverage that is likely to run or sag.

The closer the spray gun is held to the work, the thicker the paint is deposited and the faster the gun must be moved to prevent sags and runs. Holding the gun too far from the work will cause excessive fog, overspray, and a thin and grainy coat.

Do not wave the spray gun. This waving is called arching. Instead, hold the spray gun at a 12 to 15 inch distance perpendicular from the work.

# SPRAY TECHNIQUE - Continued

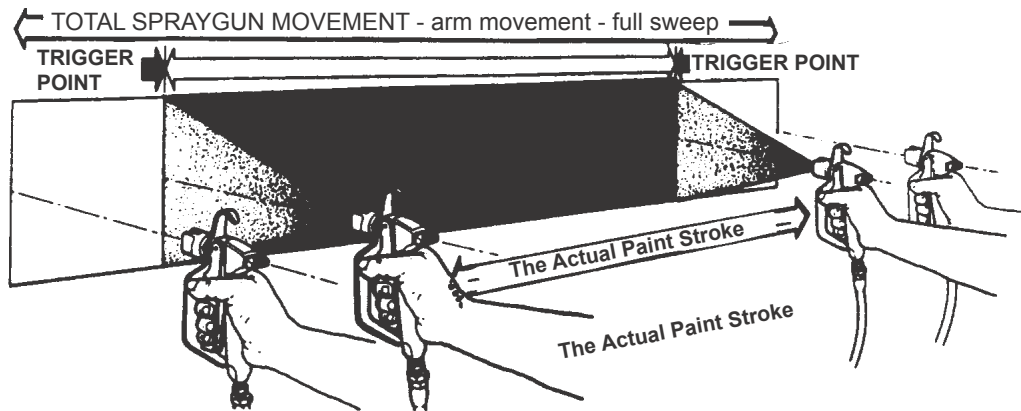

It is important to "trigger" the gun after gun movement (arm movement) has started and release trigger (shut gun off) before gun movement ends. Gun movement is always longer than actual paint (spray) stroke. In that manner, even blending and uniform paint coat thickness is achieved over the entire surface. When the gun is in motion as the trigger is pulled, it deposits an even amount of paint.



Overlap the previous pass by half the width of the spray pattern. Aim at the bottom of the previous pass.

Spray with uniform strokes from left to right and from right to left, holding stroke speed, distance, lapping, and triggering as uniform as possible.

**TAILING**

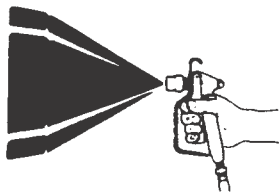

Adjust pressure control knob so that paint is completely atomized from the spray gun. Insufficient pressure will result in "tailing".

**GOOD PATTERN**

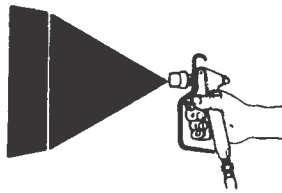

**FOG, OVERSPRAY**

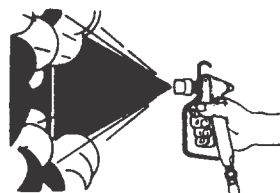

Too much pressure will result in excess fog and overspray, excessive tip wear, and increased sprayer wear and tear.

**POOR PATTERN GOOD PATTERN**



Always use the lowest pressure possible to obtain desirable results.

Test the spray pattern on a piece of cardboard or other surface.

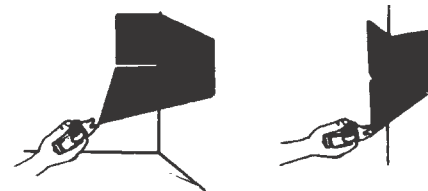

**INSIDE CORNER OUTSIDE CORNER**

"Inside" and "outside" corners can be sprayed.

Aim the spray gun toward the center of the corner. The spray pattern is divided in half, and the edges of the spray pattern on both walls are the same.

# AIRLESS SPRAY GUN OPERATION

DEFECTS	CAUSE	CORRECTION
Coarse spray	Low pressure	Increase the pressure.
Excessive fogging (overspray)	High pressure Material too thin	Reduce the pressure to satisfactory pattern distribution. Use less thinner.
Pattern too wide	Spray angle too large	Use smaller spray angle tip.
Pattern too narrow	Spray angle too small	Use larger spray angle tip (if coverage is OK, try tip in same nozzle group)
Too much material	Nozzle too large Material too thin Pressure too high	Use next smaller nozzle.  Reduce pressure.
Too little material	Nozzle too small	Use next larger nozzle Material too thick
Thin distribution in center of pattern "horns".	Worn tip Wrong tip	Change for new tip. Use nozzle with a narrow spray angle.
Thick skin on work	Material too viscous Application too heavy	Thin cautiously. Reduce pressure and/or use tip in next smaller nozzle group.
Coating fails to close & smooth over	Material too viscous	Thin cautiously.
Spray pattern irregular, deflected	Orifice clogged. Tip damaged	Clean carefully. Replace with new tip.
Craters or pock marks, bubbles on work	Solvent balance	Use 1 to 3% "short" solvents remainder "long" solvents (this is most likely to happen with material of low viscosity, lacquers etc.)
Clogged screens	Extraneous material in paint. Coarse pigments Poorly milled pigments (paint pigments glocculate)	Clean screen  Use coarse screen if orifice size allows. Use coarser screen, larger orifice tips. Obtain ball milled paint. If thinner has been added, test to see if a cover screen. Incompatible drop placed on top of paint mixes or flattens out on the paint mixture & thinners on the surface. If not, try different thinner in fresh batch of paint.

## TEST THE PATTERN

Good, full



Spotty Pattern, Increase Pressure.



# REV-TIP™ SELECTION CHART

Spray tip selection is based on paint viscosity, paint type, and job needs. For light viscosities (thin paints), use a smaller tip; for heavier viscosities (thicker paints), use a larger tip size.

Spray tip size is based on how many gallons of paint per minute can be sprayed through the tip. Do not use a tip larger than the maximum pump flow rate or capacity the sprayer can accommodate. Pump flow rate is measured in gallons per minute (GPM).

**Rev-Tip™** for **Painting P.N. 560-xxx**

**Rev-Tip™** for **Striping P.N. 562-xxxST**

For sizes not shown, call factory for availability.

### TIP IDENTIFICATION:

**1st 3-digits** identifies it as a **REV-TIP™** for airless paint spraying (P.N. 560-xxx) or a **REV-TIP™** for airless line striping (P.N. 562-xxxST).

**4th digit** is the fan width - the number is half the fan width, e.g., 5 means a 10" fan.

**5th and 6th digits** are for the orifice size and is measured in thousandths of an inch, e.g., 17 = 0.017 inch - The higher the number, the larger the tip.

Rev-Tip™ for Painting Fan Width (12" from surface) in. (mm)		SPRAY PAINTING TIP - ORIFICE SIZE (Inches)												
		.009	.011	.013	.015	.017	.019	.021	.023	.025	.027	.029	.031	.035
<b>4-6</b>	<b>102-152</b>	209	211	213	215	217	219	221	223	225	227	229		
<b>6-8</b>	<b>152-203</b>	309	311	313	315	317	319	321	323	325	327		335	
<b>8-10</b>	<b>203-254</b>	409	411	413	415	417	419	421	423	425	427	431		
<b>10-12</b>	<b>254-305</b>		511	513	515	517	519	521	523	525	527	531	535	
<b>12-14</b>	<b>305-356</b>			613	615	617	619	621	623	625	627	631	635	
<b>14-16</b>	<b>356-406</b>				715	717		721						
<b>16-18</b>	<b>406-457</b>				815		819	821				831		
<b>Gun Filter</b>	C= Coarse - 60 mesh F= Fine - 100 mesh		F	F	F,C	C	C	C	C	C	REMOVE FILTER			
<b>Wood Interior</b>	Lacquer, Varnish Stain, Sealer Enamel		.	.	.									
<b>Wood Exterior</b>	Exterior Stain Vinyl, Acrylic, Latex				.	.	.	.						
<b>Masonry</b>	Vinyl, Oil Base Alkyd Latex, Acrylic Block Filler Elastomer				.	.	.	.	.	.	.	.	.	.
<b>Ceiling</b>	Hi Build, Mil White							.	.	.	.	.	.	.
<b>Structural Steel</b>	Heavy Coatings							.	.	.	.	.	.	.
<b>Water Flow Rate</b>	(gpm) (water @ 2000psi, 138 bar)		.12	.18	.24	.31	.38	.47	.57	.67	.77	1.03	1.31	
	(lpm)		.49	.69	.91	1.17	1.47	1.79	2.15	2.54	2.96	3.90	4.98	
<b>Paint Flow Rate</b>	(gpm) (latex paint @ 2000psi, 138 bar/1.36 spec. gr.)		.10	.15	.21	.27	.33	.40	.49	.58	.66	.88	1.12	
	(lpm)		.38	.57	.79	1.02	1.25	1.51	1.85	2.20	2.50	3.33	4.24	
<b>Pump Minimum</b>	(gpm)		.25	.25	.33	.40	.50	.60	.75	.88	1.0	1.25	1.5	
<b>Output*</b>	(lpm)		1.0	1.0	1.25	1.5	1.9	2.3	2.8	3.3	3.8	4.7	5.7	
	*Pump will support tip worn to next larger size.													

Rev-Tip™ for Striping Fan Width (6" from surface) in. (mm)		STRIPING TIP - ORIFICE SIZE (Inches)												
		.009	.011	.013	.015	.017	.019	.021	.023	.025	.027	.031	.035	
<b>1-2</b>	<b>25-51</b>			113ST	115ST	117ST	119ST							
<b>2-4</b>	<b>51-102</b>				215ST	217ST	219ST	221ST						
<b>4-6</b>	<b>102-152</b>				315ST	317ST	319ST	321ST						
<b>6-8</b>	<b>152-203</b>													
<b>Striping Paint</b>				Oil Base	Oil Base	Latex	Latex	Latex	Latex	Latex	Latex			

### PATTERN WIDTH

Thickness of the paint coat per stroke is determined by spray tip "fan width", rate of the spray gun movement, and the distance to the surface being sprayed.

### SPRAY TIP SELECTION

Two tips having the same tip size, but different pattern widths will deliver the same amount of paint over a different area (wider or narrower strip). A spray tip with a narrow pattern width makes it easy to spray in tight places.

### SPRAY TIP REPLACEMENT

During use, especially with latex paint, high pressure will cause the orifice to grow larger. This destroys the pattern. Replace tips before they become excessively worn.

Worn tips waste paint, cause overspray, make cutting-in difficult, and decreases sprayer performance.

# REGULAR MAINTENANCE

1. Always stop the pump at the bottom of its stroke when you take a break or at the end of the day. This helps keep material from drying on the rod, damaging the packings.
2. Keep the displacement pump packing nut/wet cup 1/3 full of Airlessco Throat Seal Oil at all times. The TSO helps protect the packings and rod.
3. Lubricate Connecting Rod Pin every 3 months.
4. **Inspect the packing nut daily.** Your paint pump has Airlessco's patented "Triple Life Packing System".

***Packing life will be extended a minimum of 3 times if the proper packing tightening procedure is followed!***

## Packing Tightening Procedure:

Inspect the packing nut daily!

If seepage of paint into the packing nut and/or movement of the piston upward is found (while not spraying), the packing nut should be tightened enough to stop leakage only, but not any tighter.

**Overtightening Will Damage the Packings** and reduce the packing life to the life of other piston pumps.

# OIL AND LUBRICATION PROCEDURE

FIG. 8

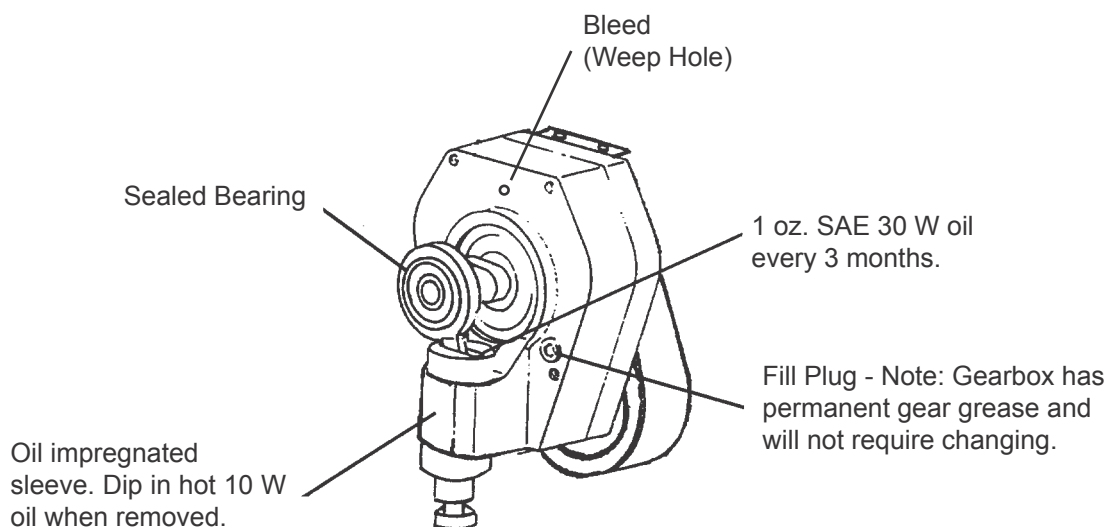

# FIELD TROUBLESHOOTING

PROBLEM	CAUSE	SOLUTION
There is spitting from the gun.	The fluid supply is low or empty.	Refill the supply container.
	Air entrapped in the fluid pump or hose.	Check for loose connections on the siphon assembly, tighten, then reprime pump.
Paint leaks into the wet cup	The packing nut/wet cup is loose.	Tighten just enough to stop leakage.
	The upper packings are worn or damaged. Worn Piston Rod.	Replace the packings. See page 17. Replace Piston Rod
The engine operates, but the paint pump doesn't cycle.	The pressure setting is too low.	Increase the pressure. See page 5.
	The clutch is not engaged. The displacement pump is seized.	See Troubleshooting pg. 19. Service the pump. See page 15

PROBLEM	CAUSE	SOLUTION
The engine and displacement pump operates, but paint pressure is too low or none	The pressure setting is too low. The tip or gun filter is clogged. The tip is worn. The fluid displacement pump filter is clogged. There is a large pressure drop in the fluid hose.	Increase the pressure, see page 4, step 5. Remove the tip and/or filter and clean them. Replace Tip. Clean the filter.  Use a larger diameter hose.
The displacement pump operates, but the output is too low on the downstroke or both strokes.	The lower check valve ball is not seating properly.	Service the lower check valve see page 16
The displacement pump operates, but the output is too low on the upstroke.	The upper check valve ball is not seating properly.  The lower packings are worn or damaged.	Service the upper check valve per page 16.  Replace the packings. See page 17.
Clutch does not engage. Clutch slippage.		See Troubleshooting page 19. Call Authorized Service Center.
Engine stops		Refer to Engine Manual.

## SERVICING FLUID PUMP

Note: Check everything in the Troubleshooting Chart before disassembling the sprayer.

### FLUID PUMP DISCONNECT

1. Flush out the material you are spraying, if possible.
2. Follow the Pressure Relief Procedure on Page 6. Stop the pump in the middle of down stroke.
3. Remove the suction tube and fluid hose (if so equipped) from the fluid pump. On the LO-BOY, detach the hose from the front of the fluid pump. (Fig. 20, item 14)
4. Remove 2 retaining rings and slip the sleeve of the coupling down and remove both coupling halves. This will disconnect fluid pump from the connecting rod. (Fig. 22, Items 10, 11 & 12)
5. Unscrew the two tie rod locknuts.
6. Pull the pump down off the tie rods.

### FLUID PUMP REINSTALL (FIG. 22)

1. Loosen the packing nut and extend piston rod to fully up position. Slip sleeve (189-047) over the piston rod.
2. Make sure that spacer tubes (301-048) are in place.
3. Connect connecting rod with fluid pump by installing coupling halves (189-046). Slide sleeve over coupling halves. Secure with retaining rings (189-048).
4. Secure the fluid pump housing to the tie rods (100-328) and screw nuts with lock washers on loosely.
5. Tighten the tie rod nuts evenly to 30 ft. lb.
6. Reconnect fluid hoses and suction tube (if so equipped).  
**NOTE: After all the rod locknuts are tight, the alignment of both rods should allow easy assembly and disassembly of the coupling. If there is any binding, loosen and retighten all the rod locknuts to improve the alignment. Misalignment causes premature wear of seal and packings.**
7. Tighten the packing nut, until there is resistance, then 1 full turn tighter. Approximately 4 threads will show, when new packings are installed. Fill the wet cup of the packing nut 1/3 full with TSO.
8. Start the pump and operate it slowly (at low engine speed and pressure setting ) to check the piston rod for binding. Adjust tie rod lock nuts if necessary to eliminate binding.
9. Run at maximum pressure for several minutes, relieve pressure and repeat step 7.

# SERVICING INLET & OUTLET VALVES

## INLET VALVE (See FIG. 9 & 11)

1. Using the rod collar tool (189-211), screw the suction nut (187-018), containing intake seat support (187-017), off of the fluid body (187-313).
2. Remove the inlet seat (187-065), O-ring (106-017), inlet ball (187-020) and ball cage (187-016) with O-ring (106-018).
3. Clean all parts and inspect them for wear or damage, replacing parts as needed. Old "O" rings should be replaced with new ones.

NOTE: Inlet seat (187-065) is reversible.

4. Clean inside of fluid body (187-313).
5. Reassemble the valve and screw it onto the fluid body if no further service is needed.

## PISTON, OUTLET VALVE (See FIG. 9 & 11)

1. Stop piston rod in middle of it's stroke. Remove retaining rings (189-048).
2. Slip the sleeve (189-047) off the coupling halves (189-046) and remove both coupling halves. This will disconnect piston rod from connecting rod and gearbox assembly.
3. Screw the suction nut (187-018) off the pump and remove inlet valve assembly.
4. Using the rod collar tool, loosen the packing nut (CCW) and push the piston down and out of the fluid body.
5. Place piston holder (187-248) in a vise. Slide the piston into the holder and lock in place with a 1/4" pin (187-250).
6. Clean all parts and inspect them carefully for wear or damage. Inspect the outside of the piston rod for scoring or wear. Replace these parts if needed. A worn piston rod will cause premature wear of packings.
7. Using a 3/8" allen wrench to unscrew the outlet seat support (187-051) from the piston (187-330).
8. Remove the outlet seat (187-061), O-ring (106-021), outlet ball (115-022) and ball cage (187-062).
9. Inspect the outlet ball and seat for wear. Replace as required.

NOTE: Inlet seat (187-061) is reversible.

10. Install parts back into piston rod as per Fig. 11, page 16. Place two drops of loctite No. 242 (blue) on threads of the outlet seat support before assembling and torque to 20 ft-lbs.

FIG. 9

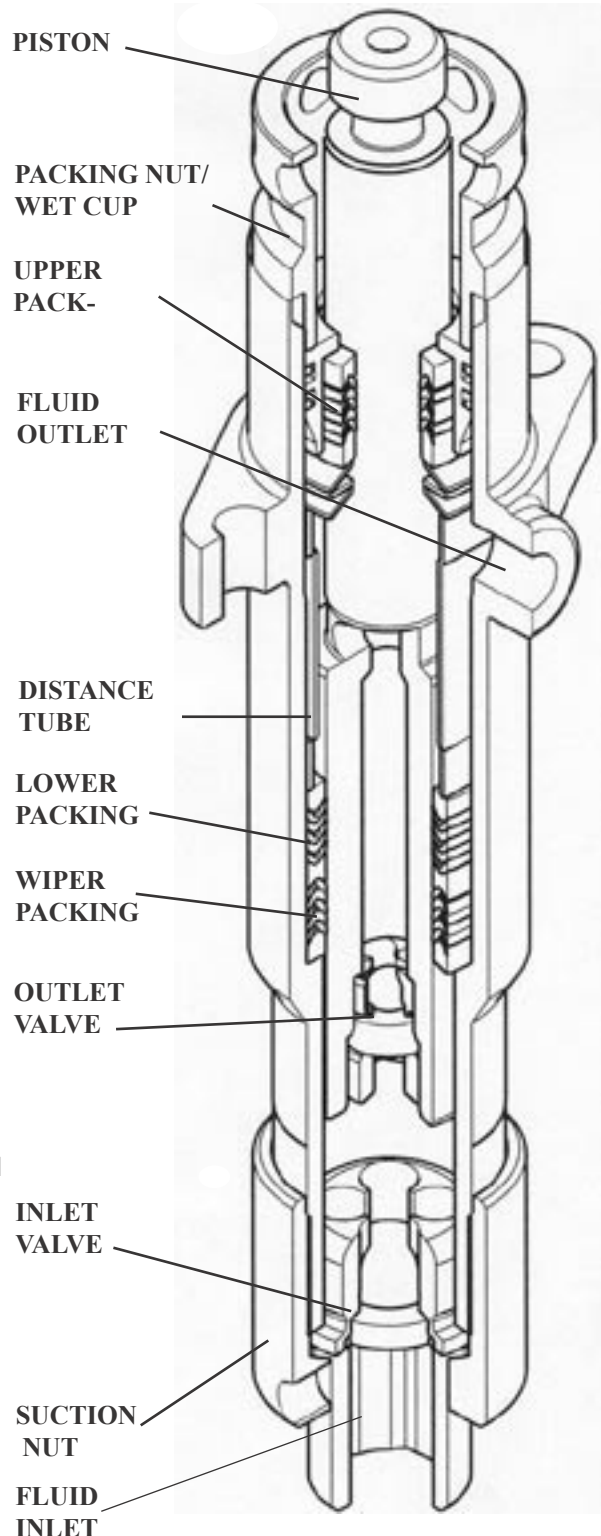



# V-PACKING REPLACEMENT

## V-PACKING REPLACEMENT KIT SEVERE DUTY- PART NO. 187-040

**Contains:** Leather & Plastic Packings,  
Teflon & Viton O-Rings, Balls &  
plastic dual sided female adaptor  
& Larger Male Glands.

**GLAND KIT - Part Number 187-064**

## V-PACKING REPLACEMENT INSTRUCTIONS (FIG. 10 & 11)

1. Remove the fluid pump as per the "Fluid Pump Disconnect" instructions on page 13.
2. Unscrew and remove the inlet valve per instructions on page 16.
3. Unscrew & remove the packing nut (187-046). Push the piston rod down through the packings and out of the pump. Utilizing packing removal tool (187-249) the complete packing set can be removed quickly and easily. Another method is to wrap some masking tape around the bottom of the piston. Now push the piston back through the pump and remove through the top. The packings and glands will be removed with the piston rod, leaving the fluid body (187-313) empty.
4. Disassemble and clean all parts for reassembly. Discard old packings.  
**Save metal upper glands (187-026 & 187-025). Replace metal lower glands 187-037 with new metal glands from Packing Kit. If the old packing had metal gland for 187-058 discard and replace with plastic 187-058.**
5. Remove the outlet seat support, outlet seat, outlet ball, O-ring and ball cage as previously described on page 16.

FIG. 10

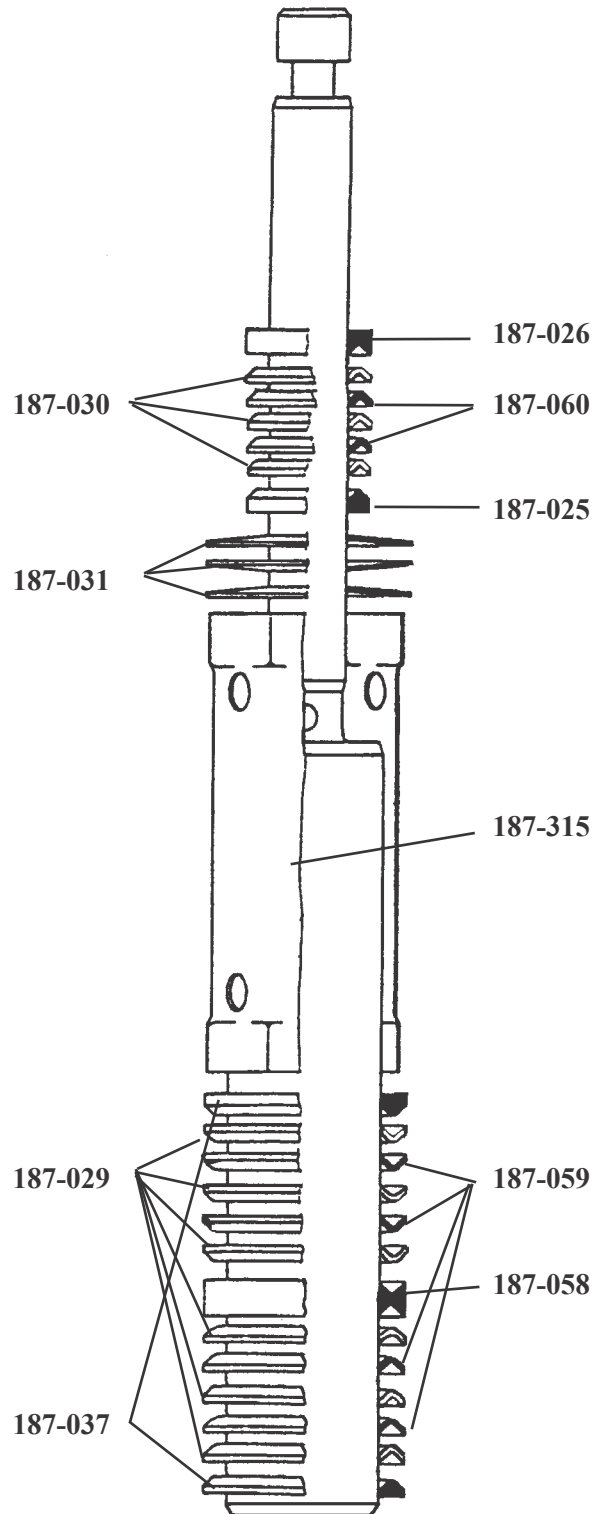

# V-PACKING REPLACEMENT (Continued)

FIG. 11

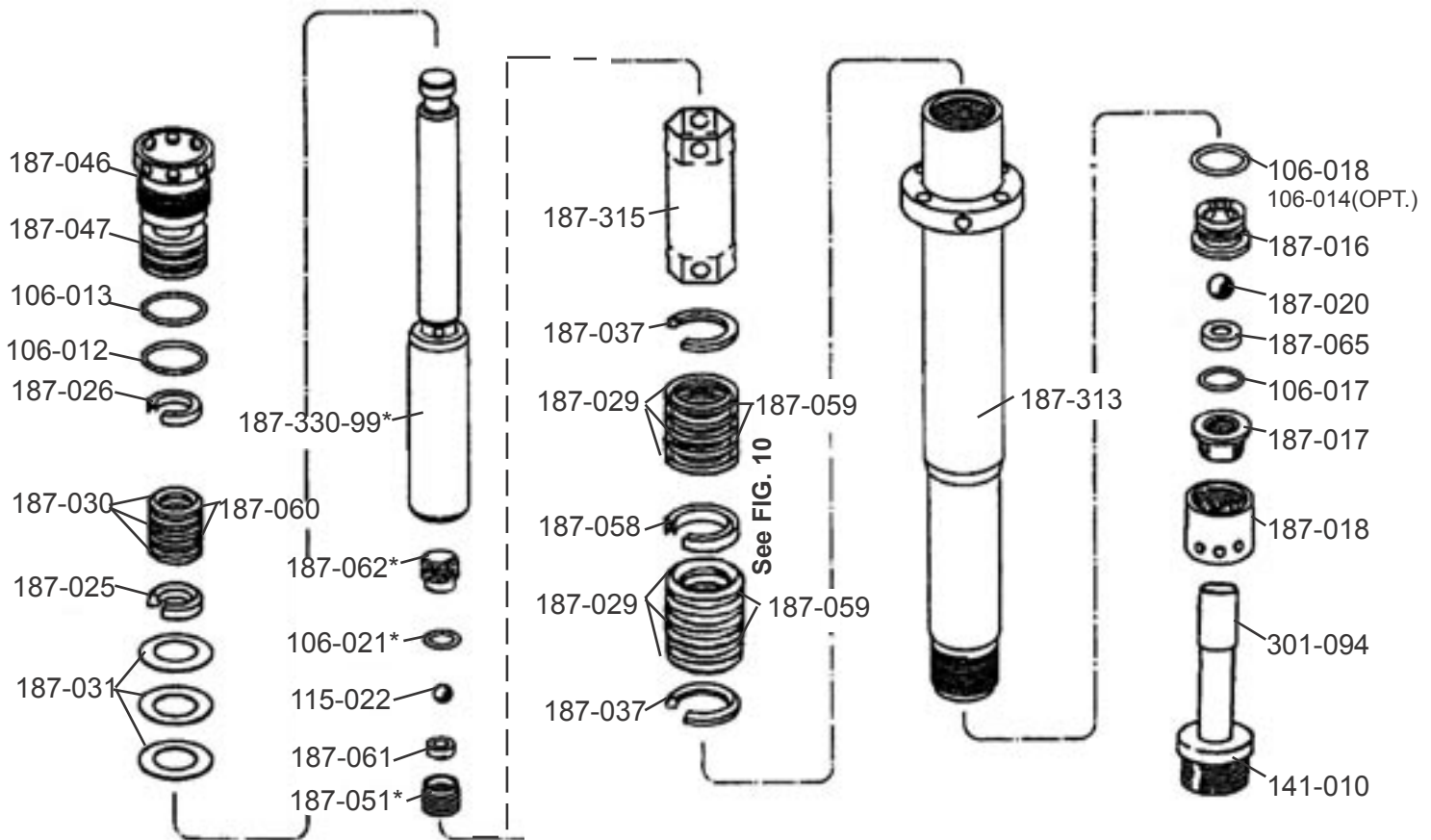

## REASSEMBLY

\* INCLUDED WITH 187-330-99 PISTON ASSEMBLY

6. Lubricate leather packings in lightweight oil for 10 minutes prior to assembly.
7. Remove masking tape from piston. (if used)
8. Reassemble all parts onto piston in the following order: (Per FIG. 10)
  - a. Start with lower metal male gland (187-037)
  - b. Five V-Packings (187-029 & 187-059). Inverted "Λ".
  - c. Female adaptor (187-058)
  - d. Five V-Packings (187-029 & 187-059). "V" up.
  - e. Upper Male gland (187-037)
  - f. Slide on distance tube (187-315)
  - g. Three Belleville Springs (187-031) starting with the first spring facing down (⤵) and next facing up (⤴) and the third facing down (⤵).
  - h. Slide on upper male gland (187-025) with bevel facing up.
  - i. Five V-Packings (187-030 & 187-060). inverted "Λ".
  - j. Female Gland (187-026)
- k. Slide on the V-Packing holder (187-047) with O-rings (106-013 & 106-012) in place over upper packings.
13. Lubricate inside of cylinder & outside of packings then slide complete assembly into the fluid body (187-313). Thread packing nut (187-046) into cylinder & tighten (handtight).
14. Install the lower check valve and tighten the lower check valve nut (187-018).
15. Connect the pump to the machine as per fluid pump reinstall procedure on page 16.
16. Tighten the packing nut (clockwise) until resistance is felt against the belleville springs. **Now turn it 1 turn clockwise.** Run unit to maximum pressure for 5 minutes.

# BALL VALVE - Part Number 100-119

FIG. 12

PARTS LIST - FIG.12		
ITEM NO.	PART NO.	DESCRIPTION
1	100-162	Handle
2	100-163	Screw
3	100-164	Ball
*	KIT-119	Repair Kit

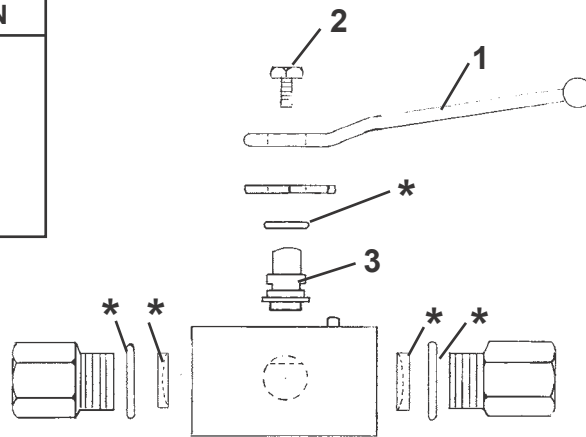

## TROUBLESHOOTING - Clutch Does Not Engage

**STEP 1:** Ensure that the pressure control knob (POT) is in the maximum (CW) position.

**STEP 2:** Remove the upper and lower clutch and electrical covers.

**STEP 3:** Check all electrical connections between the engine magneto, sensor, control board and clutch for loose connections or damaged leads. See Fig.13.

**STEP 4:** Disconnect the two leads from the control board (blue) and the clutch assembly (black). Using a multimeter, with the engine at maximum RPM, pressure control knob in the maximum position and the prime valve open (priming) position, test the DC voltage across the boards leads (blue). This voltage must be 13-14 VDC. If the readings are correct, the board, sensor and magneto are okay and the problem is the clutch assembly. If this is the case, proceed to Step 5. If the voltage is outside this range go to Step 7.

**STEP 5:** Measure resistance between the clutch leads (black). This value must be 10-16 ohms. If this reading is out of specifications the clutch is defective and must be replaced, otherwise continue troubleshooting.

**STEP 6:** If the clutch resistance readings of Step 5 are correct, check the spacing between the clutch field and plate. The gap should be .012" to .024". If the gap is greater than .028 the gap is too wide. If this gap is too wide, remove the spacer (Fig. 15, Item 4) from the clutch assembly. Should the clutch still not engage, replace the clutch assembly. See page 19 in manual.

**STEP 7:** When the DC voltage from the board is not 13-14 VDC, disconnect the control board lead (black) from the engine magneto lead (pink), located on the side of the engine. With the engine at maximum RPM, pressure control knob in maximum (CW) position and prime valve open (priming), read the AC voltage from the magneto lead to the sprayer frame. This reading should be 19-24 VAC. If outside this range, contact your local Honda repair facility for magneto replacement. If the magneto is producing the proper AC voltage, continue to Step 8.

**STEP 8:** Test the sensor by reading the resistance between the red and black wires. The resistance runs between 1.5-3 kohms. A defective sensor usually shows no resistance (open). If the reading is outside standards, replace the sensor. An alternative method to test the sensor, is to plug a new sensor into the board and see if the clutch will engage. Caution! When using this method, ensure prime/pressure valve is in the prime position. This is important because the sensor plugged into the board is not measuring pressure in the fluid section.

**STEP 9:** When Steps 7 & 8 have been completed and the magneto and sensor check good, the electrical control board is the only item left, replace the board. See page 20 in manual.

# REPLACEMENT OF ELECTRICAL CONTROL BOARD

1. Remove electrical cover. Hi Boy Fig 22 Item 37  
Lo Boy Fig 23 Item 27
2. Disconnect sensor lead from Electrical Board.
3. Disconnect two clutch leads on Electrical Board from leads on clutch.
4. Using a 1/16" allen, loosen set screw in Pressure Control Knob and remove knob.
5. Using a 1/2" nutdriver or 1/2" deep socket, remove nut from pressure control shaft. This will allow removal of electrical control board from frame.
6. Replace Electrical Board Assembly in reverse order. Adjust pressure as per procedure below, "Pressure Calibration on the Electrical Control Board".

## PRESSURE CALIBRATION ON THE ELECTRICAL CONTROL BOARD

1. Turn "Pressure Calibration" Trimpot adjustment on electrical control board in the counter clockwise direction at least 15 revolutions.
2. Connect 5000 psi glycerine pressure guage on output of pump between fluid pump & airless hose to monitor Fluid Pump Pressure.
3. Start engine and run at maximum RPM. Turn Prime/Pressure Relief Valve to the open (Prime) position. Turn Pressure Control Knob to maximum position (fully clockwise).
4. Using an insulated screwdriver, adjust "Pressure Calibration" Trimpot by turning clockwise until the clutch engages. When the clutch engages the pump will commence Priming. When pump is primed, turn the Prime/Pressure Relief Valve to the Closed (Pressure) Position
5. Trigger gun. The pressure should drop approximately 350-400 psi (when using a 3/8" hose), the clutch will engage and build pressure to 3000 psi and disengage. Trigger gun several times to ensure proper pressure setting.
6. Turn Pressure Control Knob to minimum position. The clutch should disengage and pump stop moving.
7. Secure leads with tie strap.
8. Replace cover on unit. Ensure the leads are not pinched or damaged in the process of replacing covers.

FIG. 13

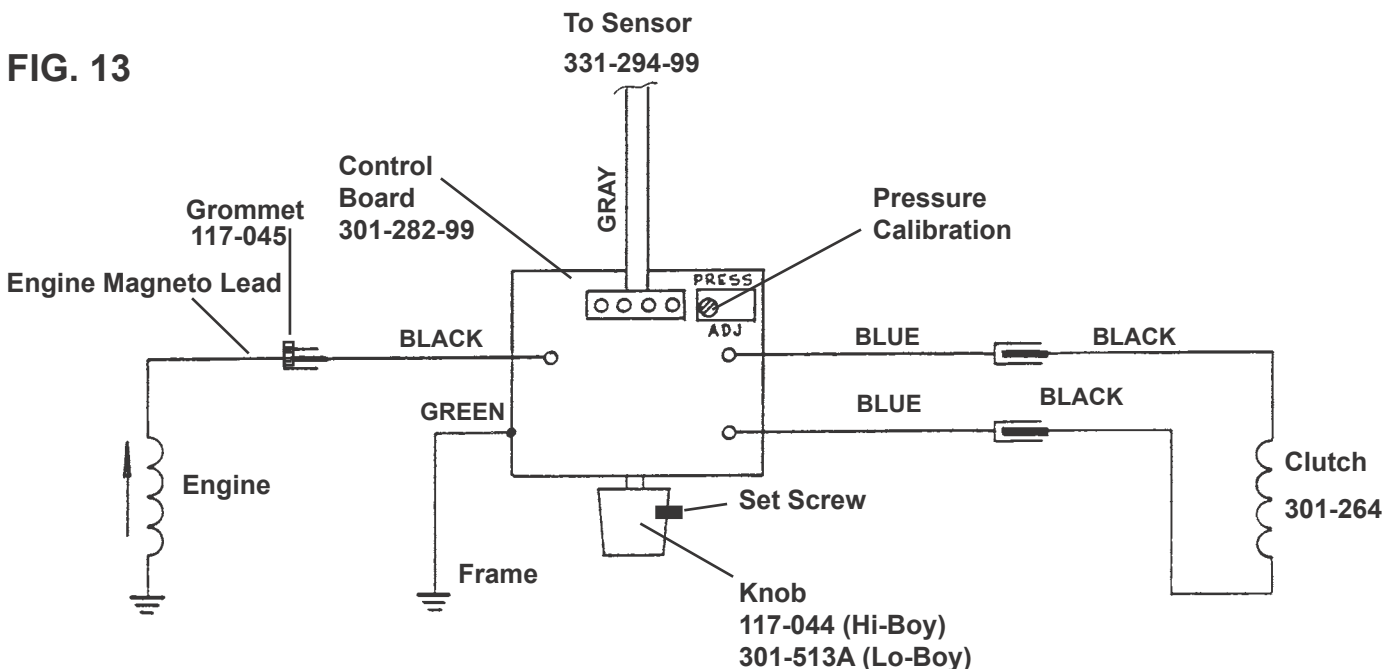

# CLUTCH REPLACEMENT - HI-BOY

## REMOVE CLUTCH AS FOLLOWS:

(See Figs. 15 & 17)

1. Remove upper and lower clutch covers (Fig. 22, Item 21,27)
2. Disconnect two clutch leads from electrical board leads. Pull clutch leads through grommet from frame.
3. Disconnect and remove fluid section from gearbox, including connecting rod assembly and cover plate.
4. Remove four bolts, (Fig. 17, Item 7), holding gearbox and clutch assembly to holder, Item 6. Remove gearbox with clutch assembly attached.

5. Place gearbox in vice by gripping the flat portion of the drive crank allowing the clutch assembly to face up. Use caution and not allow gearbox to swing and damage casting against vice.

6. Hold coupling screw, (Fig. 15, Item 2), with 13/16" wrench, then with 5/16" allen wrench screw differential screw, (Fig. 15, Item 1), out of coupling screw and gearbox shaft.

7. Screw large end of differential screw into coupling screw and pull them out of clutch assembly.

8. The clutch, Item 5, can now be removed. Items 3 to 8 should be inspected for wear, replace if needed.

## INSTALL NEW CLUTCH AS FOLLOWS:

1. With gearbox held in a vise, as described above, place first spacer, (Item 8) and bearing, (Item 6) onto gearbox shaft. (Refer to Fig. 15)

2. Insert snap rings, (Item 7), into recesses of cog pulley portion of clutch. Place cog pulley portion of clutch onto shaft.

3. Place second spacer, (Item 8) into cog pulley portion of clutch. This spacer will rest on the first bearing, (Item 6) installed.

4. Insert second bearing, (Item 6), on top of upper snap ring, (Item 5).

5. Lay removable spacer (Item 4) on top of last bearing. If the clutch air gap is larger than .028", do not use removable spacer. Put spacer (Item 3) over removable spacer, if used, and top bearing.

6. Place coil portion of clutch down onto cog pulley portion of clutch and center on gearbox shaft.

7. Screw differential screw, (Item 1) into coupling nut assembly until 1/16" is showing. (See Fig. 16).

8. Push coupling nut assembly, (Item 2), into clutch assembly until it comes to a positive stop. (Differential screw comes into contact with the threaded gearbox shaft.)

9. With 13/16" wrench on coupling screw and 5/16" allen wrench in the differential screw, simultaneously screw coupling assembly into gearbox shaft by turning clockwise until a positive stop is reached.

10. Hold coupling screw and tighten differential screw to 30 ft-lbs. This will expand the coupling assembly, thereby holding the clutch assembly to gearbox shaft. Turn clutch observing clutch gap. The pulley should turn freely with a gap of .012" to .024" between the two clutch faces. If the gap is greater than .028" remove the spacer (Item 4). Reassemble and check gap for proper clearance

11. Reconnect gearbox and clutch assembly to holder with four bolts as follows:

Place cog belt on large pulley portion of clutch. Hold belt and let gearbox hang upside down. Place belt over upper pulley on engine, (Fig.17, Item 3). Rotate gearbox upright and install bolts loosely.

Push down on gearbox with approximately 50 lbs. of force to tighten belt. Align gearbox vertically and tighten bolts.

12. Insert clutch leads back through grommet in frame and connect to electrical control board leads.

13. Connect spring, (Fig.15, Item 9) to holder, (Fig.17, Item 6).

14. Reconnect fluid section, as described on page 14.

15. Check clutch and pump for proper operation. Replace all covers.

# CLUTCH REPLACEMENT - LO-BOY

## REMOVE CLUTCH AS FOLLOWS:

1. Remove the upper and lower clutch covers (Fig. 23, Item 27, 11).
2. Remove the splash cover from the clutch brackets and spacer tubes. (Fig. 23, Item 17)
3. Disconnect the two clutch leads from the electrical control board leads.
4. Remove gearbox cover with manifold filter from gearbox.(Fig. 23, Item 30). Disconnect hose (Fig. 20, Item 14) from fluid section.
5. Disconnect and remove fluid section from gearbox, including Connecting Rod Assy. (See"Fluid Pump Disconnect, pg. 15)
6. Remove four nuts (Fig. 23, Item 23) on the engine side of (Item 18) from screws (Item 24) which pass through spacer tubes (Item 15). This will allow removal of Gearbox & Clutch Assembly from "Holder-Manifold" (Item 18).
7. Pull the cog belt loose from the engine shaft cog pulley (Fig.23, Item 10) and remove the gearbox/clutch assembly from the rest of the unit.
8. Place gearbox in vice by gripping the flat part of the drive crank allowing the clutch assembly to face up. Use caution and not allow gearbox to swing and damage casting against vice.
9. Hold coupling screw, with 13/16" wrench, then with 5/16" allen wrench, screw differential screw (Fig. 15, Item 1), out of coupling screw and gearbox shaft.
- 10.Screw large end of differential screw into coupling nut assembly (Fig. 15, Item 2) and pull out of clutch assembly.
- 11.The clutch (Fig. 15, Item 5) can now be removed.

## INSTALL NEW CLUTCH AS FOLLOWS:

1. With gearbox held as described above (Step 8), place first spacer, (Fig. 15, Item 8) and bearing, (Fig. 15, Item 6) onto gearbox shaft.
2. Insert snap rings (2), Item 7 into recesses of cog pulley portion of clutch. Place cog pulley portion of clutch with cog belt attached onto shaft.
3. Place second spacer, (Item 8) into cog pulley portion of clutch. This spacer will rest on the first bearing, (Item 6) installed.
4. Insert second bearing, (Item 6) on top of upper snap ring, (Item 7).

## INSTALL NEW CLUTCH CONTINUED

5. Lay removable spacer (Item 4) on top of last bearing. If the clutch air gap is larger than .028", do not use removable spacer. Put spacer (Item 3) over removable spacer, if used, and top bearing.
6. Place coil portion of clutch down onto cog pulley portion of clutch and center on gearbox shaft.
7. Screw differential screw, (Item 1) into coupling screw and nut (Item 2) until 1/16" is showing. (See Fig. 16)
8. Push coupling nut assembly, (Item 1 & 2) into clutch assembly until it comes to a positive stop. (Differential screw comes into contact with the threaded gearbox shaft.)
9. With 13/16" wrench on coupling screw and 5/16" allen wrench in differential screw, simultaneously with both wrenches screw coupling nut assembly into gearbox shaft by turning clockwise until a positive stop is reached.
10. Hold coupling nut ass'y and tighten differential screw to 30 ft.-lbs. This will expand the coupling assembly, thereby holding the clutch assembly to gearbox shaft. Turn clutch observing clutch gap. The pulley should turn freely with a gap of .012 to .024" between the two clutch faces. If the gap is greater than .028, remove the spacer (Item 4). Reassemble and check gap for proper clearance.
11. Place Cog Belt over Cog Pulley portion of clutch. Loosen set screws (Fig. 14, Item 6) until set screws are approximately 1/4" above Block Tensioner (Item 7)
12. Reassemble the Spacers (Fig. 23, Item 15) onto screws. (Item 24). Simultaneously lift gearbox assembly with clutch into position by placing Cog Belt over engine shaft log pulley and inserting the four Screws (Item 24) into Holder-Manifold (Item 18) and replacing Nuts (4) (Item 23). Tighten nuts to hold assembly in place.
13. Slightly loosen Screws (4) (Fig. 14, Item 5).
14. Evenly tighten Set Screws (Fig. 14, Item 6) until flush with tip of Block Tensioner (Item 7). Check tension on Cog Belt by pressing hard with thumb. Proper tensioning should allow for approximately 1/8". If belt is too loose, tighten Set Screws further.
15. Replace Connecting Rod and Fluid Section. Preplace Front Cover on gearbox. Connect Hose (Fig. 20, Item 14) to fluid section.
16. Connect the clutch and board leads. Connect Spring (Figure 15, Item 10) to spacer tube.
17. Replace the splash shield.
18. Test the clutch for proper operation.
19. Replace clutch covers.

# CLUTCH REPLACEMENT - LO-BOY

FIG 14 PARTS LIST		
ITEM NO.	PART NO.	DESCRIPTION
1	301-231	Cog Belt
2	301-264	Clutch Replacement
3	305-088	Screw
4	100-175	Shoulder Screw
5	100-173	Screw Flanged (4)
6	100-174	Set Screw (2)
7	301-534	Block Tensioner
8	301-208	New Gearbox
9	305-045	Plate
10	305-046	Spacer Tube (4)

FIG. 14

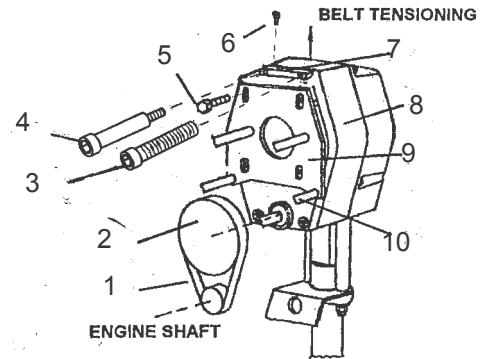

# CLUTCH ASSEMBLY HI-BOY/LO-BOY

FIG. 15

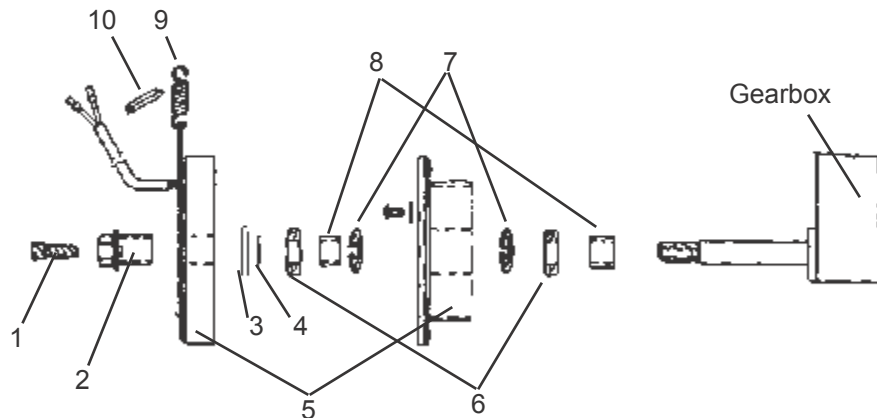
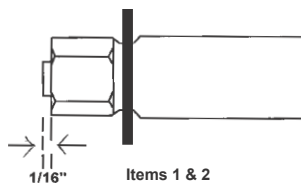

FIGURE 15 PARTS LIST					
ITEM NO.	PART NO.	DESCRIPTION	ITEM NO.	PART NO.	DESCRIPTION
1	112-041	Screw-Differential	6	301-037	Bearing (2)
2	112-054	Coupling Nut Assy	7	100-333	Retaining Ring (2)
3	301-412	Spacer	8	301-274	Spacer (2)
4	301-413	Spacer-Removable	9	136-068	Spring
5	301-264	Clutch-Replacement	10	301-316	Rubber Edge

FIG. 16



# ENGINE ASSEMBLY HI-BOY

FIG. 17

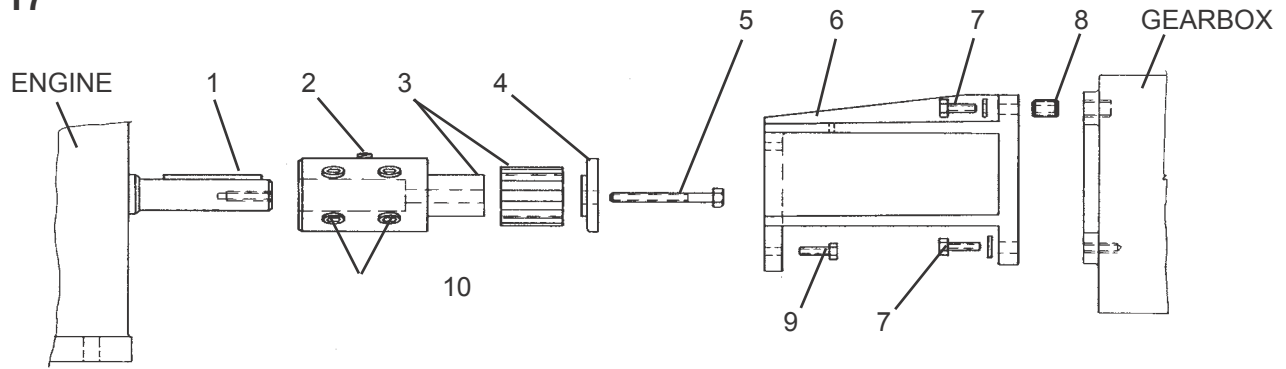

FIGURE 17 PARTS LIST

ITEM NO.	PART NO.	DESCRIPTION	ITEM NO.	PART NO.	DESCRIPTION
1	112-029	Key (3/16 x 1 1/2)	8	301-272	Insert (2)
2	100-357	Screw, Soc (1)	9	136-091	Screw, cap 5/16 - 24 (4)
3	301-222A	Hub/Sheave Ass'y	10	100-383	Screw, soc 3/8 - 24 (4)
4	301-229	Thrust Plate			
5	301-230	Screw Cap (5/16-24X 2 1/4)			
6	301-271	Holder			
7	100-169	Screw , cap 5/16 - 18 (4)			

# ENGINE ASSEMBLY LO-BOY

FIG. 18

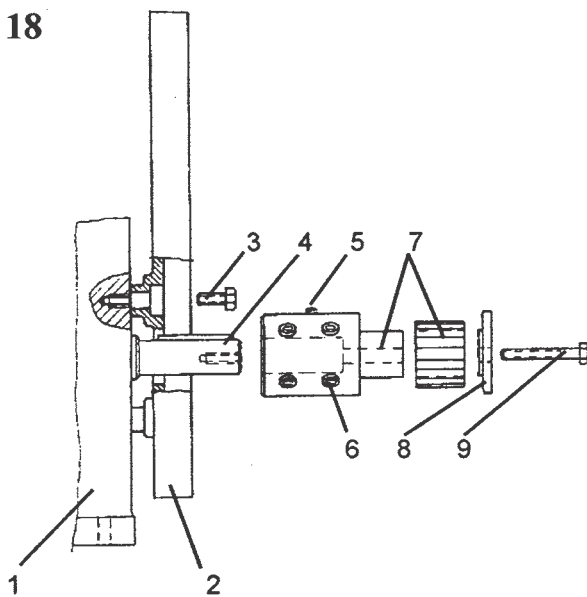

FIG. 18, ENGINE ASS'Y

ITEM NO.	PART NO.	DESCRIPTION
1	301-160	Honda 5.5HP Engine
2	305-012	Adaptor
3	136-091	Screw (4)
4	112-029	Key
5	100-357	Screw (set)
6	100-383	Screw (4)
7	301-222A	Sheave Assly.
8	301-229	Thrust Plate
9	301-230	Screw



# PAINT SYSTEM ASSEMBLY - HI-BOY Part Number 301-452

FIG. 19

Part #	Description
100-028	1/4" Plug
100-070	1/4" x 1/4" Nipple
100-109	3/8" x 1/4" Nipple
100-119	Ball Valve
100-123	3/8" x 21" Hose
100-129	3/8" Plug
100-141	3/8"M x 1/4"M Elbow
100-161	3/8" Cap w/ Ring
100-224	1/4" Barb
100-226	1/4"M x 1/4"F Fitting
111-200	Filter Assembly
169-010	3/8" x 3/8" Nipple
169-013	3/8"M x 3/8"F Elbow
187-313	Pump Body (SL)
301-260	Manifold
301-526	3/8" x 15" Hose
305-140	Filter Bracket
331-294	Sensor Assembly
331-424	ByPass Hose

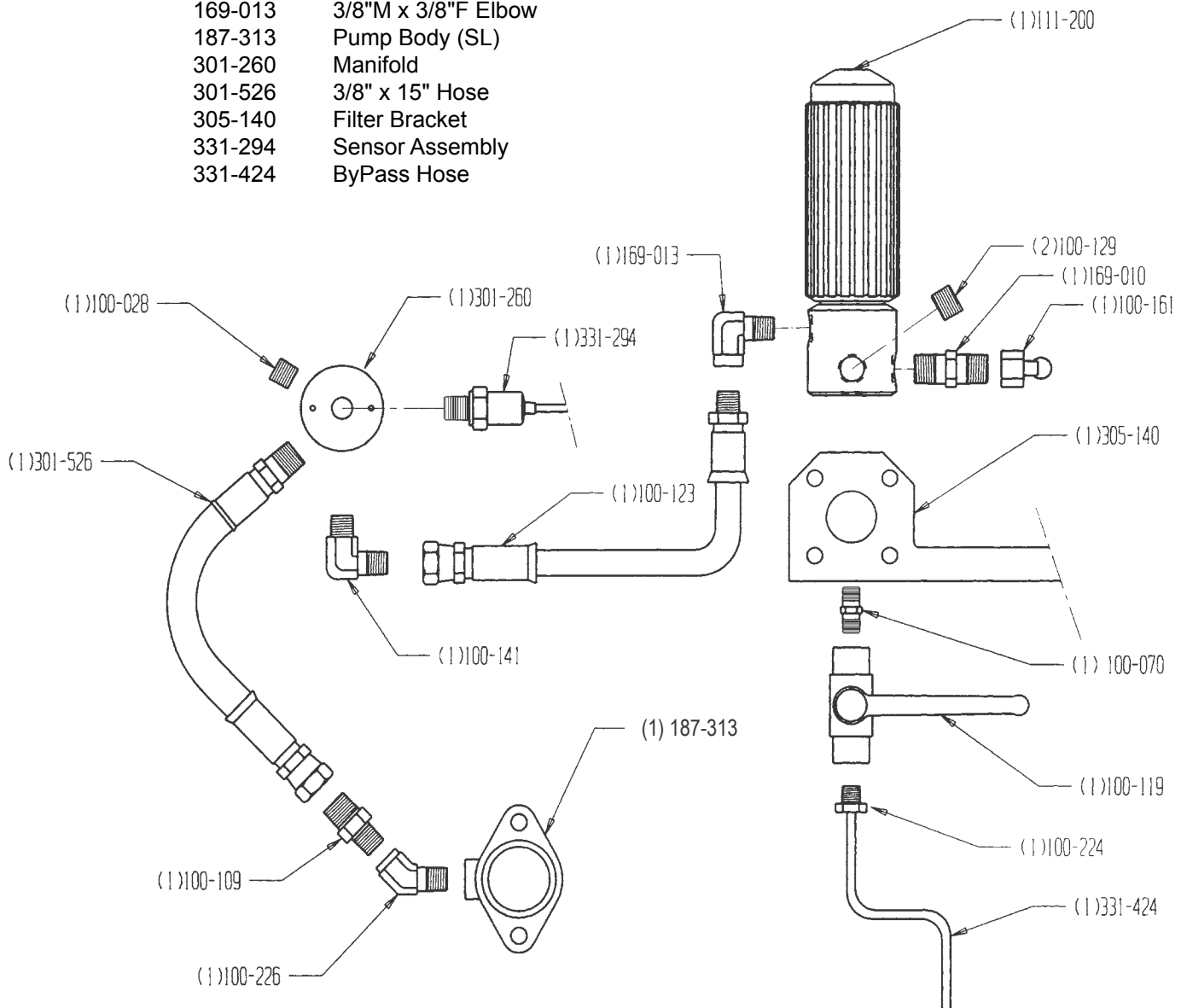

# PAINT SYSTEM ASSEMBLY - LO-BOY

FIG. 20

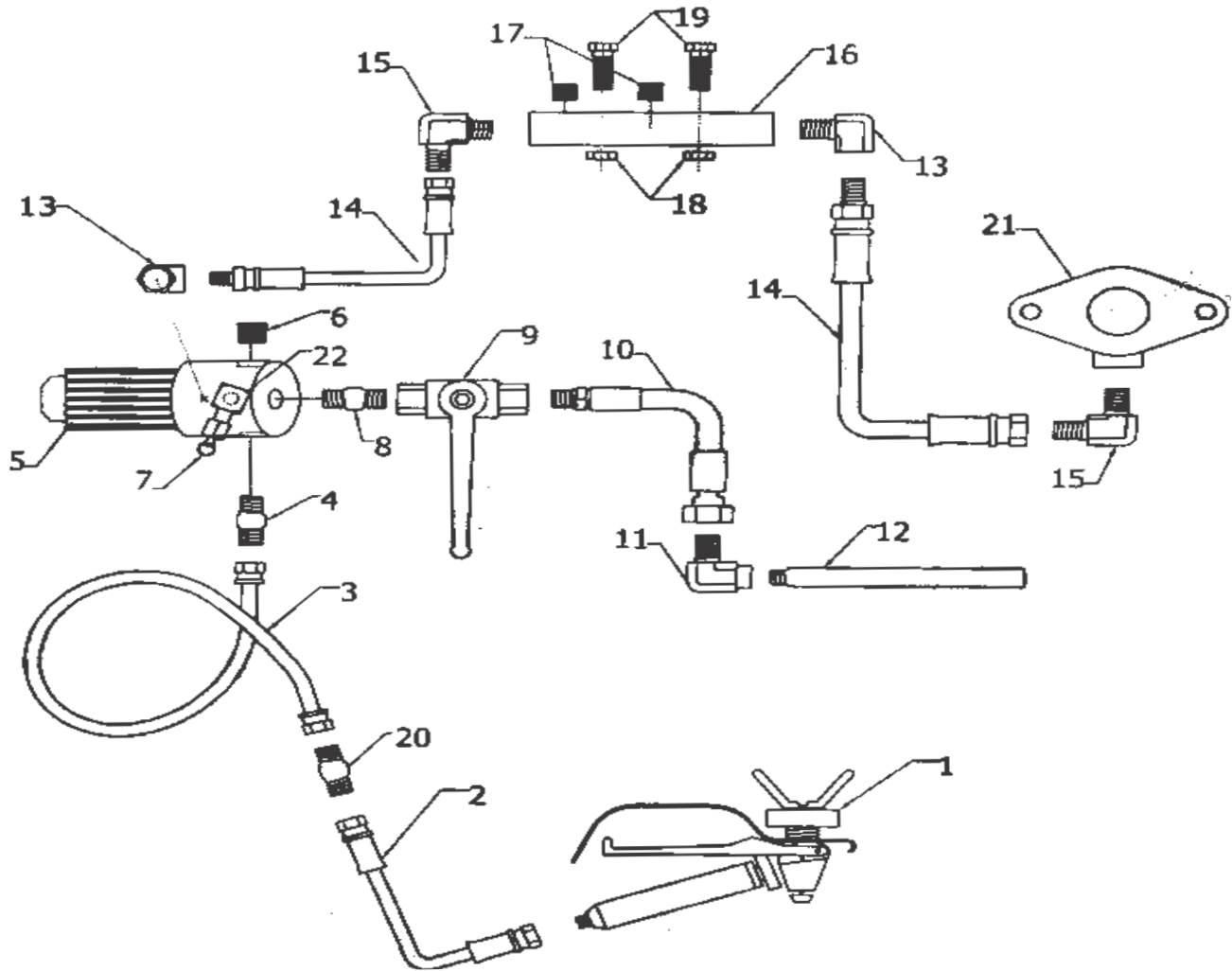

FIG. 20 PARTS LIST, PAINT SYSTEM ASSEMBLY

ITEM NO.	PART NO.	DESCRIPTION	ITEM NO.	PART NO.	DESCRIPTION
1	120-201XL	007 Gun w/Swivel (Optional)	12	188-177	1/4" Return Tube
2	100-111	50' x 1/4" Hose (Optional)	13	169-013	3/8"M x 3/8"M Elbow (x2)
3	100-023	50' x 3/8" Hose	14	100-123	3/8"F x 3/8"M x 21" Hose (x2)
4	169-010	3/8"M x 3/8"M Nipple	15	100-141	1/4"M x 3/8"M Elbow
5	111-200-99	Manifold Filter Assembly	16	301-253	Manifold
6	100-129	3/8" Plug	17	100-028	1/4" Plug (x2)
7	100-161	3/8" Cap w/ Ring	18	100-317	1/4" Nut (x2)
8	100-070	1/4" x 1/4" Nipple	19	100-345	1/4" Bolt (x2)
9	100-119	Ball Valve	20	100-109	3/8M x 1/4M NPS Nipple
10	100-012	1/4"M x 1/4"F x 4' Swivel Hose	21	187-410	SL Fluid Pump
11	100-004	1/4"M x 1/4"F Elbow	22	167-016	3/8M x 3/8M Elbow

# MANIFOLD FILTER - PN 111-200-99

FIG. 21

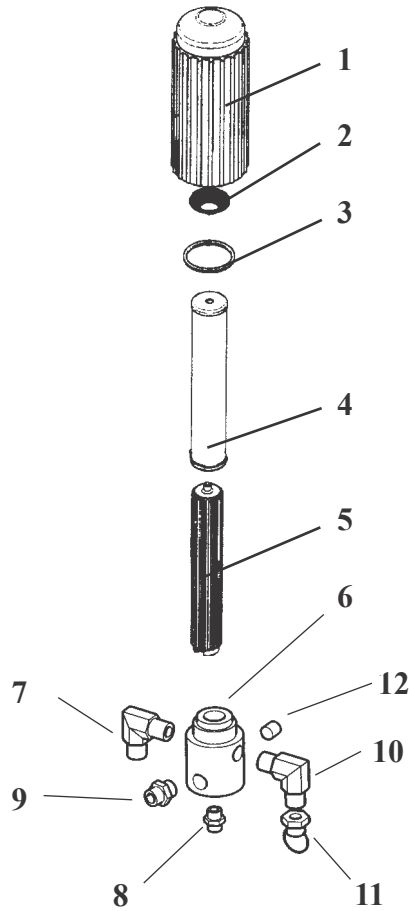
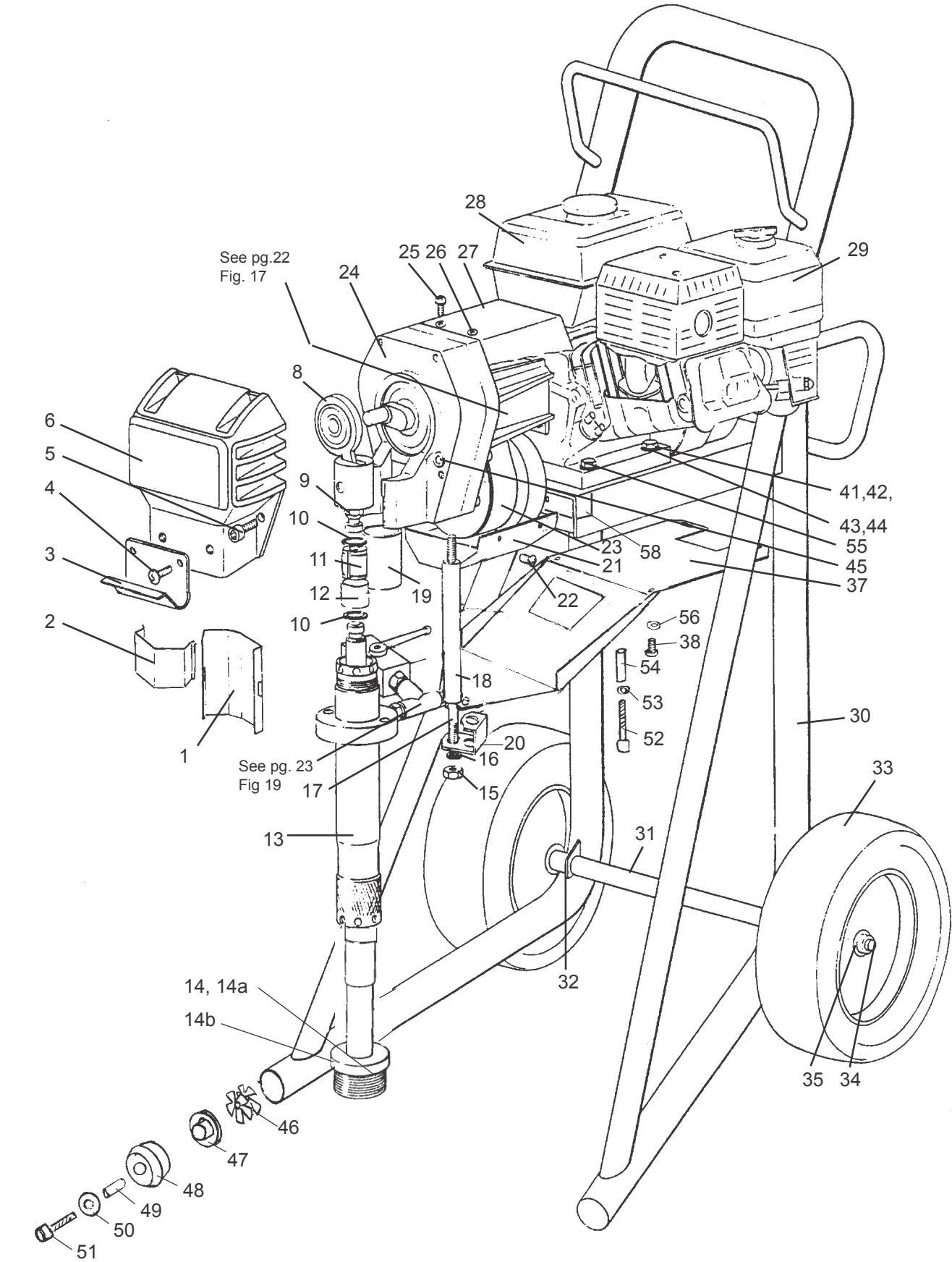

FIGURE 21 PARTS LIST		
ITEM	PART NO.	DESCRIPTION
1	111-202	Base*
2	301-356	Spring*
3	106-007	O-Ring*
4	111-204	Filter
5	111-203	Support*
6	111-201	Base*
7	169-013	3/8" M x 3/8" M Elbow
8	100-034	3/8" NPT (M) x 3/8" NPS (M) Hose Connector
9	100-129	Plug 3/8"
10	169-013	3/8" NPT (M) x 3/8" NPS (M) Elbow
11	100-161	3/8" Cap with Ring
*	111-200	Filter Assy.
12	100-028	Plug 1/4 NPT

# COMPLETE SPRAYER - HI BOY

FIG. 22



# FIGURE 22 PARTS LIST

ITEM NO.	PART NO.	DESCRIPTION	ITEM NO.	PART NO.	DESCRIPTION
1	301-092	Shield - rear	29	175-021	Air Filter , Engine
2	301-189	Shield - front	30	301-239	Frame Weldment, Gas
3	301-105	Hook	31	301-149	Spacer
4	100-360	Screw (2)	32	163-016	Spacer (2)
5	100-312	Screw (4)	33	301-165	Wheel (2)
6	301-320	Cover -gearbox	34	301-170	Axle
8	301-291	Connecting Rod Ass'y	35	143-029	Set Collar (2)
9	301-046	Rod End	36	301-134	Solid Neoprene Stopper (2)
10	189-048	Retaining Ring (2)	37	301-326	Bottom Cover
11	189-046	Coupling Set	38	100-390	Screw (4)
12	189-047	Coupling Cover	41	140-029	Washer 5/16 (8)
13	187-410	Fluid Pump	42	136-123	Screw, 5/16 (4)
14	301-090-99	Suction Ass'y, 16" (5 gal.)	43	140-029	Washer , Flat (4)
14a	301-543-99	Suction Ass'y, 36" (55 gal.)	44	100-317	Nut, 5/16 (4)
14b	141-010	Inlet Strainer	45	100-028	Plug, 1/4
15	140-051	Nut (2)	46	119-015	Tube Connector (2)
16	140-035	Washer, Lock (2)	47	112-056	Spacer (2)
17	100-328	Stud (2)	48	163-029	Shock Mount (2)
18	301-048	Spacer, Tube (2)	49	188-185	Spacer (2)
19	301-047	Sleeve Bearing	50	163-011A	Washer (2)
20	301-173	Retainer	51	100-172	Screw (2)
21	301-280	Clutch Cover - bottom	52	100-318	Screw (2)
22	111-037	Screw (4)	53	100-034	Washer (2)
23	301-231	Cog Belt	54	301-068	Spacer (2)
24	301-208	Gear Box Gas	55	100-317	Nut, Center Lock (2)
25	100-339	Screw (2)	56	140-029	Washer (2)
26	301-135	Grommet (6)		188-160	Ground Ass'y
27	301-254	Clutch cover, Top	58	112-057	Mount Bar
28	301-160	Honda Eng. QXS160(5.5hp)		117-044	Knob Ass'y for Potentiometer

FOR SAFETY, KEEP ALL LABELS ON UNIT CLEAN AND READABLE.  
ORDER NEW LABELS AS REQUIRED.

# POWER UNIT ASSEMBLY - LO-BOY

**FIG. 23**

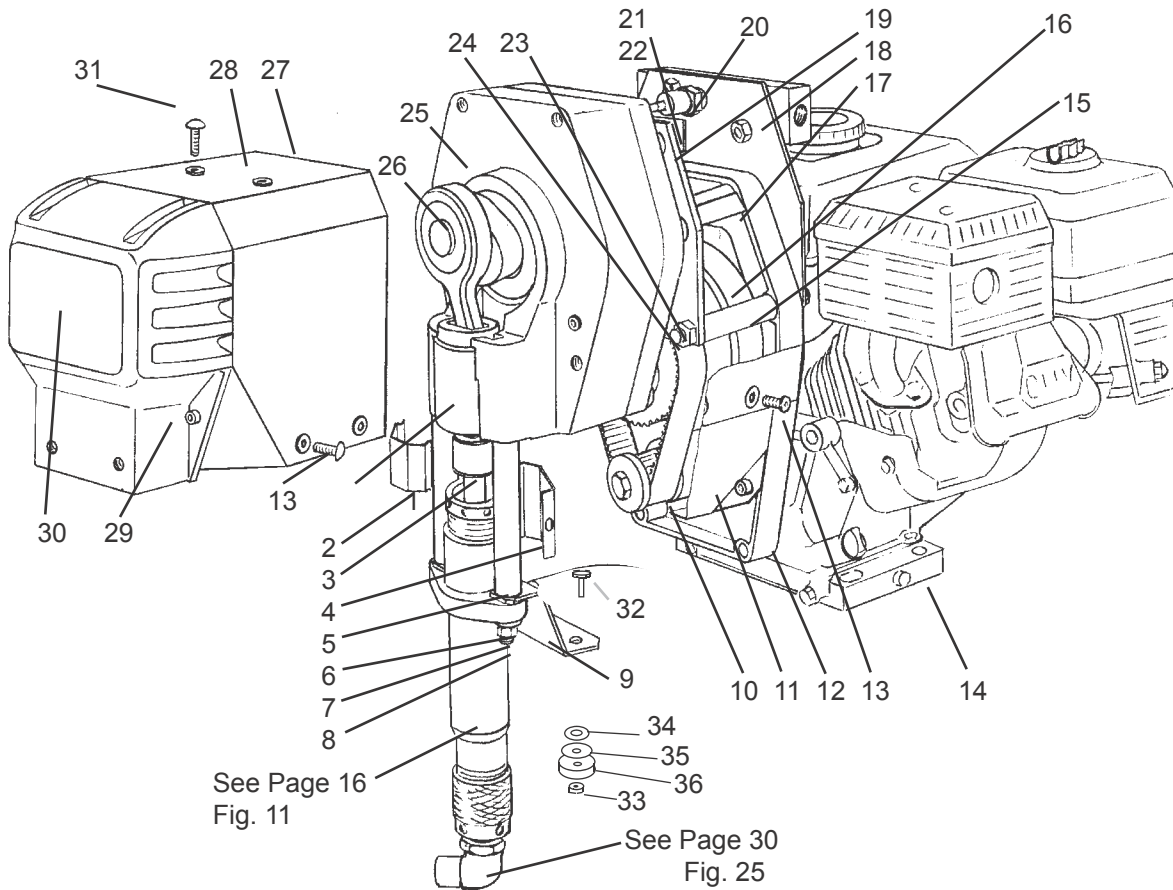

**FIG. 23 PARTS LIST, POWER UNIT ASSEMBLY, PN 301-530**

Item No.	Part No.	Description	Item No.	Part No.	Description
1	301-047	Sleeve Bearing	18	305-064	Holder-Manifold
2	301-189	Shield Front	19	305-045	Plate - Gearbox Mount
3	189-046A	Coupling Set Ass'y	20	331-294-99	Sensor Ass'y
4	301-092	Shield - Rear	21	301-282-99	Pressure Control Board
5	301-048	Spacer - Tube (2)	22	301-523A	Knob Ass'y
6	140-035	Washer, Lock (2)	23	140-044	Nut (8)
7	140-051	Nut (2)	24	305-047	Screw (4)
8	100-328	Stud (2)	25	301-208	Gearbox
9	305-013	Holder	26	301-333	Connecting Rod Ass'y
10	301-231	Cog Belt	27	301-531	Cover Top
11	305-067	Cover-Bottom	28	301-135	Grommet (6)
12	305-012	Adaptor	29	100-312	Screw (4)
13	100-339	Screw (4)	30	301-320	Cover -Gearbox
14	301-524	5.5 HP Engine Ass'y	31	301-337	Screw (2)
15	305-046	Spacer Tube (4)	32	301-547	Bolt (2)
16	301-264	Clutch Ass'y	33	100-317	Lock Nut (2)
17	301-529	Cover	34	140-029	Washer (4)
			35	100-344	Washer (4)
	188-160	Ground Ass'y	36	301-536	Shock Mount (4)

# FRAME ASSEMBLY - LO-BOY

FIG. 24

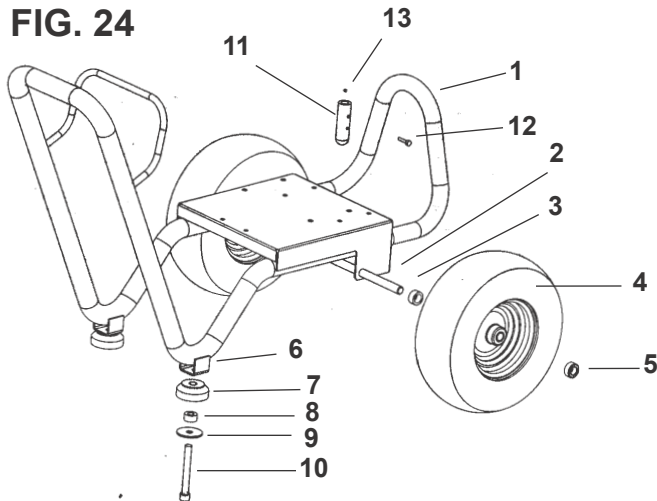

FIG. 24 PARTS LIST, FRAME ASS'LY, 301-515

ITEM #	PART NO.	DESCRIPTION
1	301-510	Frame Weldment
2	188-367	Axle 5/8 x 21.81"
3	113-031	Spacer 5/8" ID x 1"
4	301-165	Wheel (2) 13x500-6
5	143-029	Set Collar (2) 5/8"
6	100-317	Centerlock Nut (2) 5/16-18
7	163-008A	Rubber Foot (2)
8	188-185	Spacer (2) .25X .08WX
9	163-011A	Washers (4) 1.25 x .31
10	169-050	Screw (2) 5/16-18 x 1
11	100-170	Cup
12	301-546	Screw 10-24 x 1.7
13	120-021	Nut 10-24 Vinyl

Above Part Numbers are for quantity one only.

# SUCTION ASSEMBLY - 5 GAL. - P.N. 301-090-99

FIG. 25

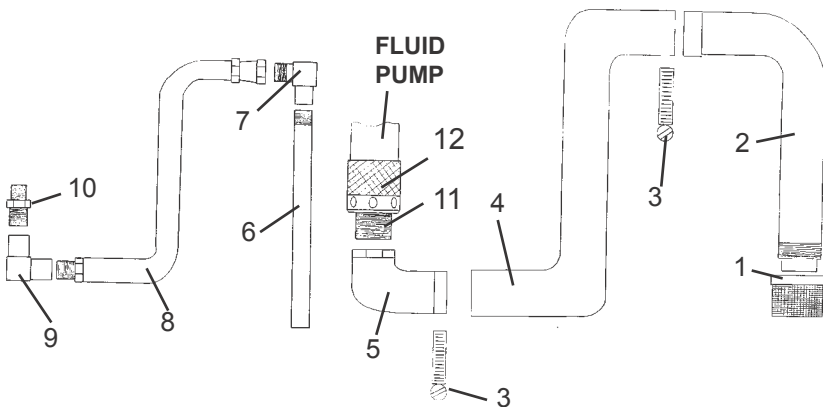

FIG.25 PARTS LIST

ITEM NO	PART NO.	DESCRIPTION
*	301-517	Suction Hose Ass'y (includes items 1-5)
1	141-008	Inlet Strainer
2	301-514	Suction Tube
3	301-516	Hose Clamps (2)
4	301-513A	Hose
5	100-165	Elbow
6	188-377	Return Pipe
7	100-128	Elbow
8	100-012	Whip
9	100-126	Elbow **
10	100-385	Reducer**
11	187-017	Fitting
12	187-018	Suction Nut

\*\* used on units equipped with either the 100-180 or 331-050 prime valves. The 301-090 suction ass'y also includes the 100-081A Elbow for units with the 138-001 marathon prime valve.

# SUCTION ASSEMBLY - 55 GAL. - P.N. 301-543-99

FIG. 26

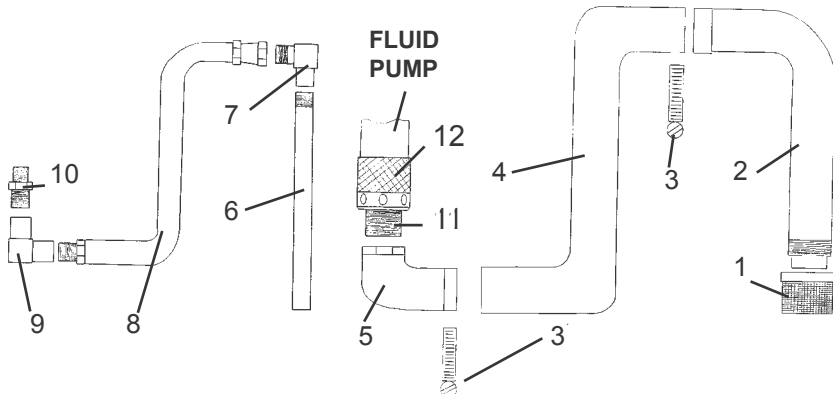

FIG. 26 PARTS LIST

ITEM NO	PART NO.	DESCRIPTION
1	141-008	Inlet Strainer
2	301-545	Suction Tube
3	301-516	Hose Clamps (2)
4	301-544	Hose
5	100-165	Elbow
6	188-377	Return Pipe
7	100-128	Elbow
8	100-012	Whip
9	100-126	Elbow **
10	100-385	Reducer**
11	187-017	Fitting
12	187-018	Suction Nut

\*\* used on units equipped with either the 100-180 or 331-050 prime valves. The 301-090 suction ass'y also includes the 100-081A Elbow for units with the 138-001 marathon prime valve.



## PUMP CONDITIONER

Should be used on piston pumps between uses to prevent paint from drying on the piston & causing packing wear.

- 010-001 Display of 48 - 1 oz. bottles
- 010-009 1 quart bottle
- 010-019 1 Gallon bottle

Case quantity: 12 on quarts, 4 on gallons



## PAINT STRAINERS

Pre filter your paint using strainer bags. One dozen per pack.

- 100-064 Used to cover suction filter
- 100-065 5 Gallon strainer



## HOSE COVER

4 mil clear poly protects your airless hose from paint and abrasion damage. Comes in 1000' roll with perforations every 50'.

- 100-219 Hose Cover Roll
- 100-426 Case of 6 Rolls



## HIGH PRESSURE HOSE

*Strong yet flexible, suitable for Airless equipment up to 3000 PSI*

- Part No: \_\_\_\_\_
- 100-012 3/16" Whip Hose, 4 Ft.
  - 100-011 1/4" Hose, 50 Ft.
  - 100-023 3/8" Hose, 50 Ft.
  - 100-037 1/2" Hose, 50 Ft.
  - 100-010 1/4" Hose Connector
  - 100-009 3/8" Hose Connector



## SPRAY TIP ADAPTER

- 032-012 "F to G" Gun adapter to attach Graco® tips to Airlessco 007 Spray Gun.



## GUN FILTERS

- 120-090CX Coarse
- 120-090FX Fine
- 120-088 Filter Spring



For a complete listing of all available accessories see the Airlessco Accessories Catalog, Part # 001-357.



## STAY CLEAN™

Spray protectant for machine to prevent paint from sticking to it.

- 114-030 20 oz. can
- Case quantity: 12 cans



## THROAT SEAL OIL

Used in the wet cup of a piston pump to prevent paint from drying on the piston & causing damage to the upper packing. Use with all piston pumps.

- 188-187 6 oz. Bottle
- 188-392 1 qt. Bottle

## XTEND-A-POLE SYSTEM

Tip Extensions - Complete with Patented SPRAY CLEAN REV-GUARD

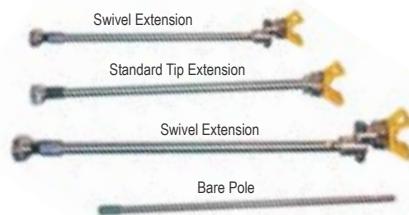

### TIP EXTENSIONS, "G" THREAD

- 032-170 6" Long
- 032-171 12" Long
- 032-172 18" Long
- 032-173 24" Long

### SWIVEL EXTENSION, "G" THREAD

- 032-184 36" Long

### EXTENSIONS (BARE POLES)

Add Tip Extension or Swivel Extension to create desired length

- 032-053 24" Long
- 032-054 36" Long



### SWIVEL "G" THREAD

- 032-035 7/8" - 14 Swivel

### ADAPTERS



- 90° Pole to Gun Adapter
- 032-042



- Gun Nut "F" Thread 11/16-16
- 032-010



- Gun Nut "G" Thread
- 032-011