



AIRLESS PAINT SPRAYER SERVICE/OPERATION MANUAL



**AIRLESSCO - SL810 & 1100
ALLPRO - 910E & 1110E**

TABLE OF CONTENTS

SECTION	FIGURE
Introduction.....	1
Safety Warnings	2
Flushing	5
How To Flush.....	5
Setting Up.....	6
Starting Up	6
Pressure Relief Procedure	8
Airless Spray Gun Operation	9
Airless Spray Troubleshooting	11
Spray Tip Selection Guide.....	12
Regular Maintenance	13
Oil and Lubrication Instructions.....	13
Electric Motor Maintenance.....	13
Field Troubleshooting	14
Replacement and Belt Adjustment	14
Servicing the Fluid Pump	15
Servicing Inlet and Outlet Valves	16
Packing Replacement Procedures	17
Paint System	19
Manifold Filter.....	19
Complete Sprayer Assembly.....	20
Complete Sprayer Parts List	21
Suction Assembly 5 Gal.	22
Suction Assembly 55 Gal.	22
Troubleshooting - Machine does not start.....	23
Pressure Control Assembly Calibration	24
Electrical System.....	25
Replacement of Electrical Components	26
Notes	27
Airlessco Accessories	30
1. Spray Gun Tip	5
2. Pressure Control knob	5
3. Flushing	5
4. Flushing	5
5. Throat Seal Oil	6
6. Controls	6
7. Gun Safety Latch	9
8. Gun Components	9
9. Spray Tip	9
10. Spray Tip Assembly.....	9
11. Airless Spray Gun.....	10
12. Oil and Lubrication	13
13. Belt Replacement	14
14. Fluid Pump Connection	15
15. Fluid Pump Connection	15
16. Fluid Pump Connection	15
17. Fluid Pump Connection.....	15
18. Fluid Pump Connection	15
19. Fluid Pump Connection	15
20. Inlet Valve	16
21. Outlet Valve	16
22. V-Packings	18
23. V-Packings	18
24. Paint System	19
25. Manifold Filter.....	19
26. Complete Sprayer	20
27. Suction Assembly (5gal).....	22
28. Suction Assembly (55gal)	22
29. Electrical System.....	25
30. Liquid Crystal Display.....	26



INTRODUCTION



Your new Airlessco or ALLPRO airless series paint sprayers are designed to meet the demands of the professional painting contractor as well as the homeowner. The famous Airlessco slow-stroking stainless steel piston pump delivers extra long life for the piston, packings, valve seats and balls. The patented Triple-Life packing system is externally adjustable, extending packing life and reducing repacking costs. Its large high-torque electric motor runs slower reducing heat. The motor is fan cooled and totally enclosed to reduce brush wear and to prevent the ignition of paint fumes in the motor.

Model 810, 910E, 1100, and 1110E spray a wide range of coatings from latex to block filler, elastomerics, and epoxy.

	SL810 910E	SL1100 1110E
Max Pressure	3300 PSI	3300 PSI
Output (FreeFlow)	0.90 GPM	1.10 GPM
Output (At Pressure)	0.80 GPM	1.00 GPM
Tip Size (1 Gun)	0.031 in.	0.033 in.
Tip Size (2 Gun)	0.019 in.	0.021 in.
Motor	DC TEFC 1.25 HP	DC TEFC 1.25 HP
Weight	135 lbs	141 lbs

WARNING

**HANDLE THIS UNIT AS YOU WOULD A LOADED FIREARM!
HIGH PRESSURE SPRAY CAN CAUSE EXTREMELY
SERIOUS INJURY. OBSERVE ALL WARNINGS!**

MANUAL NOTATIONS

WARNING - Alerts user to avoid or correct conditions that could cause bodily injury.

CAUTION - Alerts user to avoid or correct conditions that could cause damage to or destruction of equipment.

IMPORTANT - Alerts users to steps or procedures that are essential to proper equipment repair and maintenance.

NOTE - Identifies essential procedures or extra information.

BEFORE OPERATING THIS UNIT, READ AND FOLLOW ALL SAFETY WARNINGS AND INSTRUCTIONS RELATED TO THE USAGE OF THIS EQUIPMENT ON PAGES 2, 3 & 4. READ, LEARN, AND FOLLOW THE PRESSURE RELIEF PROCEDURE ON PAGE 8 OF THIS MANUAL.

All Service Procedures to be performed by an Authorized Airlessco Service Center **ONLY**.
NO MODIFICATIONS or alterations of any **AIRLESSCO** Equipment or part is allowed.

WARNINGS

MEDICAL ALERT - Airless Spray Wounds

If any fluid appears to penetrate your skin, get **EMERGENCY MEDICAL CARE AT ONCE. DO NOT TREAT AS A SIMPLE CUT.** Tell the doctor exactly what fluid was injected. Have him read the following "NOTE TO PHYSICIAN".

NOTE TO PHYSICIAN: Injection in the skin is a traumatic injury. It is important to treat the injury surgically as soon as possible. **DO NOT DELAY** treatment to research toxicity. Toxicity is a concern with some exotic coatings injected directly into the blood stream. Consultation with a plastic surgeon or reconstructive hand surgeon may be advisable.

WARNING

HIGH PRESSURE SPRAY CAN CAUSE EXTREMELY SERIOUS INJURY. OBSERVE ALL WARNINGS. THIS SPRAYER IS FOR PROFESSIONAL USE ONLY.

INJECTION HAZARD

FLUIDS UNDER HIGH PRESSURE FROM SPRAY OR LEAKS CAN PENETRATE THE SKIN AND CAUSE EXTREMELY SERIOUS INJURY, INCLUDING THE NEED FOR AMPUTATION.

NEVER point the spray gun towards anyone or at any part of the body.

NEVER put hand or fingers over the spray tip. Do not use rag or other materials over your fingers. Paint will penetrate through material and into the hand.

NEVER try to stop or deflect leaks with your hand or body.

ALWAYS have gun tip guard in place when spraying.

ALWAYS lock gun trigger when you stop spraying.

ALWAYS remove tip from the gun to clean it.

NEVER try to "blow back" paint, it's not an air sprayer.

ALWAYS follow the **PRESSURE RELIEF PROCEDURE**, as shown on page 8, before cleaning or removing the spray tip or servicing any system equipment.

Be sure equipment safety devices are operating properly before each use.

ALWAYS tighten all fluid connections before each use.

MEDICAL TREATMENT

If any fluid appears to penetrate your skin, get **EMERGENCY CARE AT ONCE.**

DO NOT TREAT AS A SIMPLE CUT.

- Go to an emergency room immediately.
- Tell the doctor you suspect an injection injury.
- Tell him what kind of material you were spraying with and have him read **NOTE TO PHYSICIAN** above.

GENERAL PRECAUTION

NEVER alter equipment in any manner.

NEVER smoke while in spraying area.

NEVER spray highly flammable materials.

NEVER use around children.

NEVER allow another person to use sprayer unless he is thoroughly instructed on its' safe use and given this operators manual to read.

ALWAYS wear a spray mask, gloves and protective eye wear while spraying.

ALWAYS ensure fire extinguishing equipment is readily available and properly maintained.

NEVER LEAVE SPRAYER UNATTENDED WITH PRESSURE IN THE SYSTEM. FOLLOW PRESSURE RELIEF PROCEDURES ON PAGE 8.

ALWAYS INSPECT SPRAYING AREA

Keep spraying area free from obstructions.

Make sure area has good ventilation to safely remove vapors. **NEVER** keep flammable material in spraying area. **NEVER** spray in vicinity of open flame or other sources of ignition. Spraying area must be at least 20 ft. away from spray unit.

SPRAY GUN SAFETY

ALWAYS set safety lock on the gun in "**LOCKED**" position when not in use and before servicing or cleaning.

DO NOT remove or modify any part of gun.

ALWAYS remove spray tip when cleaning.

Flush unit with **LOWEST POSSIBLE PRESSURE.**

CHECK operation of all gun safety devices before each use. Be very careful when removing the spray tip or hose from gun. A plugged line contains fluid under pressure. If the tip or line is plugged, follow the **PRESSURE RELIEF PROCEDURE** as outlined on page 8.

TIP GUARD

ALWAYS have the tip guard in place on the spray gun while spraying. The tip guard alerts you to the injection hazard and helps prevent accidentally placing your fingers or any part of your body close to the spray tip.

SPRAY TIP SAFETY

USE EXTREME CAUTION when cleaning or changing spray tips. If the spray tip clogs while spraying, engage the gun safety latch immediately.

ALWAYS follow the **PRESSURE RELIEF PROCEDURE** before removing the spray tip to clean it.

NEVER wipe off build up around the spray tip.

ALWAYS remove tip & tip guard to clean **AFTER** pump is turned off and the pressure is relieved by following the **PRESSURE RELIEF PROCEDURE.**

WARNINGS CONTINUED ON NEXT PAGE.....

WARNINGS - CONTINUED

HOSES

Tighten all fluid connections securely before each use. High pressure fluid can dislodge a loose coupling or allow high pressure spray to be emitted from the coupling and result in an injection injury or serious bodily injury.

Use only hose that has a spring guard. The spring guard helps protect the hose from kinks or other damage which could result in hose rupture and cause an injection injury.

NEVER use a damaged hose, which can result in hose failure or rupture and cause in injection injury or other serious bodily injury or bodily damage. Before each use, check entire hose for cuts, leaks, abrasion or bulging of cover, or damage or movement of couplings. If any of these conditions exist, replace the hose immediately. Never use tape or any device to try to mend the hose as it cannot contain the high pressure fluid. **NEVER ATTEMPT TO RECOUPLE THE HOSE.** High pressure hose is not recoupleable.

Help prevent damage to the hose by handling and routing it carefully. Do not move the sprayer by pulling it with the hose.

LABELING

Keep all labels on the unit clean and readable. Replacement labels are available from manufacturer.

TOXIC FLUID HAZARD

Hazardous fluid or toxic fumes can cause serious injury or death if splashed in eyes or on skin, inhaled or swallowed. Know the hazards of the fluid you are using. Store & dispose of hazardous fluids according to manufacturer, local, state & national guidelines.

ALWAYS wear protective eyewear, gloves, clothing and respirator as recommended by fluid manufacturer.

GROUNDING

Ground the sprayer and other components in the system to reduce the risk of static sparking, fire or explosion which can result in serious bodily injury and property damage.

ALWAYS GROUND ALL OF THESE COMPONENTS:

1. Sprayer: Connect a ground wire and clamp (supplied) to a true earth ground.
2. Fluid Hose: use only grounded hoses.
3. Spray gun or dispensing valve: grounding is obtained through connection to a properly grounded fluid hose and pump.
4. Object being sprayed: according to your local code.
5. All solvent pails used when flushing should only be metal pails which are conductive.

Once each week, check electrical resistance of hose (when using multiple hose assemblies, check overall resistance of unpressurized hose must not exceed 29 megohms (max) for any coupled length or combination of hose lengths. If hose exceeds these limits, replace it immediately.

Never exceed 500 Ft. (150 m.) overall combined hose length to assure electrical continuity.

KEEP CLEAR OF MOVING PARTS

Keep clear of moving parts when starting or operating the sprayer. Do not put your fingers into any openings to avoid amputation by moving parts or burns on hot parts. Precaution is the best insurance against an accident.

When starting the engine, maintain a safe distance from moving parts of the equipment.

Before adjusting or servicing any mechanical part of the sprayer, follow the **PRESSURE RELIEF PROCEDURE** on page 8, and remove the ignition cable from the spark plug to prevent accidental starting of sprayer.

UL RECOMENDATION FOR MINIMUM GAUGE EXTENSION CORD

AMPERAGE RATING RANGE	VOLTAGE	LENGTH OF CORD IN FEET								
		25	50	100	150	200	250	300	400	500
5-6	120	18	16	12	12	10	10	8	8	6
6-8	120	18	16	12	10	10	8	6	6	6
8-10	120	18	14	12	10	8	8	6	6	4
10-12	120	16	14	10	8	8	6	6	4	4

WARNINGS CONTINUED ON NEXT PAGE.....

WARNINGS - CONTINUED

AVOID COMPONENT RUPTURE

This sprayer operates at 3000 psi (205 bar). **ALWAYS** be sure that all components and accessories have a maximum working pressure of at least 3000 psi to avoid rupture which can result in serious bodily injury including injection and property damage.

NEVER leave a pressurized sprayer unattended to avoid accidental operation of it which could result in serious bodily injury.

ALWAYS follow the **PRESSURE RELIEF PROCEDURE** whenever you stop spraying and before adjusting, removing or repairing any part of the sprayer.

NEVER alter or modify any part of the equipment to avoid possible component rupture which could result in serious bodily injury and property damage.

NEVER use weak or damaged or non-conductive paint hose. Do not allow kinking or crushing of hoses or allow it to vibrate against rough or sharp or hot surfaces. Before each use, check hoses for damage and wear and ensure all fluid connections are secure.

REPLACE any damaged hose. **NEVER** use tape or any device to mend the hose.

NEVER attempt to stop any leakage in the line or fittings with your hand or any part of the body. Turn off the unit and release pressure by following **PRESSURE RELIEF PROCEDURE**.

ALWAYS use approved high pressure fittings and replacement parts.

ALWAYS ensure fire extinguishing equipment is readily available and properly maintained.

WARNING: Do not use halogenated solvents in this system. The prime valve, 2 gun manifold and most airless guns have aluminum parts and may explode. Cleaning agents, coatings, paints or adhesives may contain halogenated hydrocarbon solvents. **DON'T TAKE CHANCES!** Consult your material suppliers to be sure. Some of the most common of these solvents are: Carbontetrachloride, Chlorobenzene, Dichloroethane, Dichloroethyl Ether, Ethylbromide, Ethylchloride, Tetrachloroethane. Alternate valves and guns are available if you need to use these solvents.

IMPORTANT: United States Government safety standards have been adopted under the Occupational Safety & Health Act. These standards, particularly the General Standards, Part 1910, & the Construction Standards, part 1926 should be consulted.

WHEN SPRAYING & CLEANING WITH FLAMMABLE PAINTS OR THINNERS:

1. When spraying with flammable liquids, the unit must be located a minimum of 25 feet away from the spraying area in a well ventilated area. Ventilation must be sufficient enough to prevent the accumulation of vapors.
2. To eliminate electrostatic discharge, ground the spray unit, paint bucket and spraying object. Use only high pressure airless hoses approved for 3000 psi which is conductive.
3. Remove spray tip before cleaning gun and hose. Make contact of gun with bucket and spray without the tip in a well ventilated area, into the grounded steel bucket.
4. Never use high pressure in the cleaning process. **USE MINIMUM PRESSURE.**
5. Do not smoke in spraying/cleaning area.

PREVENT STATIC SPARKED FIRE/ EXPLOSIONS

ALWAYS be sure all equipment and objects being sprayed are properly grounded.

ALWAYS ground sprayer, paint bucket and object being sprayed. See "grounding" on page 3 for detailed grounding information.

Vapors created when spraying can be ignited by sparks. To reduce the risk of fire, always locate the sprayer at least 20 feet (6 m.) away from the spray area.

DO NOT plug in or unplug any electrical cords in the spray area, which can create sparks, when there is any chance of igniting vapors still in the air. Follow the coating & solvent manufacturers safety warnings and precautions.

Use only conductive fluid hoses for airless applications. Be sure gun is grounded through hose connections. Check ground continuity in hose & equipment. Overall (end to end) resistance of unpressurized hose must not exceed 29 megohms for any coupled length or combination of hose length. Use only high pressure airless hoses with static wire approved for 3000 psi.

FLUSHING

Reduce the risk of injection injury, static sparking or splashing by following the specific cleaning procedure on page 5 and 10.

ALWAYS follow the **PRESSURE RELIEF PROCEDURE** on page 8.

ALWAYS remove the spray tip before flushing. Hold a metal part of the gun firmly to the side of a metal pail and use the lowest possible fluid pressure during flushing.

NEVER use cleaning solvents with flash points below 140 degrees F. Some of these are: acetone, benzene, ether, gasoline, naphtha. Consult your supplier to be sure.

NEVER SMOKE IN THE SPRAYING/CLEANING AREA.

NEVER leave water in fluid pump, to prevent freezing during storage.

FLUSHING

1. NEW SPRAYER

Your unit was factory tested in an oil solution which was left in the pump. Before using oil-base paint, flush with mineral spirits only.

Before using water-base paint flush with mineral spirits, followed by soapy water, then a clean water flush.

2. CHANGING COLORS

Flush with a compatible solvent such as mineral spirits or water.

3. CHANGING FROM WATER-BASE TO OIL-BASE PAINT

Flush with soapy water, then mineral spirits.

4. CHANGING FROM OIL-BASE TO WATER-BASE PAINT

Flush with mineral spirits, followed by soapy water, then a clean water flush.

5. STORAGE

Oil-base paint: Flush with mineral spirits.

Water-base paint: Flush with water, then mineral spirits and leave the pump, hose and gun filled with mineral spirits.

For longer storage, use mixture of mineral spirits and motor oil (half & half). Shut off the sprayer, follow **PRESSURE RELIEF PROCEDURE** on page 8 to relieve pressure and make sure prime valve is left open.

ALWAYS store unit indoors.

6. START UP AFTER STORAGE

Before using water-base paint, flush with soapy water and then a clean water flush.

When using oil-base paint, flush out the mineral spirits with the material to be sprayed.

HOW TO FLUSH

FIG. 1

REMOVE SPRAY TIP



FIG. 2

PRESSURE CONTROL KNOB



FIG. 3

CLOSED
(Pressure)

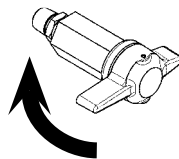

PRIME VALVE

OPEN

(Priming & Pressure Relief)

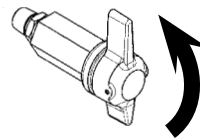

FIG. 4

MAINTAIN FIRM METAL TO METAL CONTACT
BETWEEN GUN AND CONTAINER



Flushing Procedure

1. Be sure the gun safety latch is engaged and there is no spray tip in the gun. Refer to Fig. 1. Refer to your separate instruction manual provided with your gun on its safety features and how to engage safety latch.
2. Pour enough clean, compatible solvent into a large, empty metal pail to fill the pump and hoses.
3. Place the suction tube into the pail or place the pail under the pump.
4. Turn pressure control knob to low. Refer to Fig. 2.
5. Open the prime valve to the open - "Priming Position". This will allow an easy start. Refer to Fig. 3.
6. Turn the engine ON/OFF switch to ON.
7. Point the gun into the metal pail and hold a metal part of the gun firmly against the pail Refer to fig.4.
8. Disengage the gun safety latch and squeeze the trigger. At the same time, slowly turn the pressure control knob clockwise just enough to move liquid at low pressure.
9. Allow the pump to operate until clean solvent comes from the gun.
10. Release the trigger and engage the gun safety latch.
11. If you are going to start spraying, place the pump or suction tube into the supply container. Release the gun safety latch and trigger the gun into another empty, metal container, holding a metal part of the gun firmly against the metal pail (Fig. 4), forcing the solvent from the pump and hose. When paint starts coming from gun, turn pressure control knob to minimum pressure, place prime valve in prime (open) position and engage the gun safety latch.
12. If you are going to store the sprayer, remove the suction tube or pump from the solvent pail force the solvent from the pump and hose. Engage the gun safety latch and refer to the "Storage" Procedure above. Step 5.
13. Whenever you shut off the sprayer follow **PRESSURE RELIEF PROCEDURE** warning on page 8.

WARNING: To reduce the risk of static sparking, which can cause fire or explosion, always hold a metal part of the gun firmly against the metal pail when flushing. This also reduces splashing. Refer to Fig 4.

SETTING UP

1. CONNECT THE HOSE AND GUN

- Remove the plastic cap plug from the outlet and screw a conductive or grounded 3000 psi spray hose onto fluid outlet.
- Connect an airless spray gun to the other end of the hose, but do not install the spray tip yet!

NOTE: Do not use thread sealer on swivel unions as they are made to self seal.

2. FILL THE PACKING NUT/WET CUP

FIG. 5

Fill the Packing Nut/Wet Cup with 5 drops of Airlessco Throat Seal Oil (TSO).

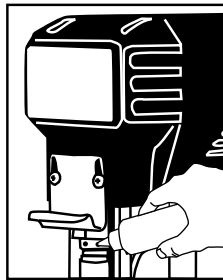

3. ELECTRICAL SERVICE

Be sure the electrical service is 120 VAC, 15 amp minimum, and that the outlet you use is properly grounded. **NOTE: FOR GENERATOR POWER, A MINIMUM OF 7000 WATT GENERATOR WITH VOLTAGE REGULATION MUST BE USED.**

4. GROUNDING

WARNING: To reduce the risk of static sparking, fire or explosion which can result in serious bodily injury and property damage, always ground the sprayer and system components and the object being sprayed, as instructed in the safety warning section of this manual.

5. FLUSH THE SPRAYER

Follow "Flushing Procedure" on page 5 of this manual.

STARTING UP

1. LEARN THE FUNCTIONS OF THE CONTROLS.

PRIME/PRESSURE (PR) RELIEF VALVE is used to prime pump and to relieve pressure from gun, hose and tip. Prime/Pressure Relief Valve

PRESSURE CONTROL KNOB is used to adjust pressure. Turn clockwise (CW) to increase pressure and counterclockwise (CCW) to decrease pressure.

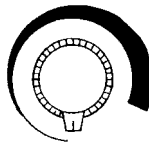

(Prime/PR Valve) Used to relieve pressure from gun, hose & tip and to prime the unit when in **OPEN** position. (It is in open position when there is a wider gap between valve handle and cam body.)

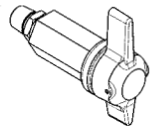

When in **CLOSED** position, there is only a very slight gap between handle & body. When closed the system is pressurized. Handle as a loaded firearm!

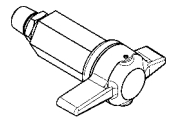
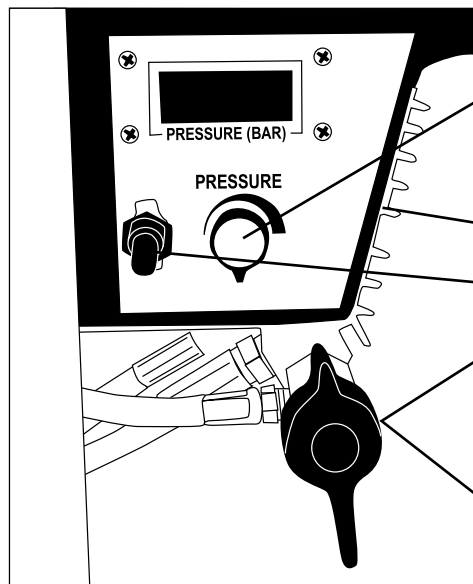

FIG. 6



PRESSURE CONTROL KNOB: used to adjust pressure only. Turn clockwise to increase pressure and counterclockwise to decrease pressure.

35 AMP CIRCUIT BREAKER

ON/OFF SWITCH

PRIME/PRESSURE RELIEF VALVE (PRIME/PR VALVE): Used to relieve pressure from gun/hose/tip and to prime the unit when in **OPEN** position. (It is in open position when there is a wider gap between valve handle and cam body). Learn and follow the **PRESSURE RELIEF PROCEDURE** on page 8 of this manual. When in closed position (very slight gap) the system is pressurized and ready to spray.

When you turn the valve handle and the gap between the valve handle and the cam body becomes wider - this means the valve is in the open position. It is in the closed position when the gap becomes very small.

STARTING UP

2. PREPARE THE MATERIAL

- Prepare the material according to the material manufacturer's recommendations.
- Place the suction tube into the material container.

3. STARTING THE SPRAYER

- Prime/PR Valve must be "OPEN" in the priming position.
- When you have ensured that the gun safety latch is engaged, attach tip and safety guard.
- Turn the engine ON/OFF switch to the "ON" position.
- Turn Pressure Control Knob clockwise to prime the pump.
- After the pump is primed, turn Prime/PR Valve to the "Closed" position.
- Turn Pressure Control Knob to the desired spray pressure.
- Disengage the gun safety latch and you are ready to spray.

4. ADJUSTING THE PRESSURE

- Turn the Pressure Control Knob Clockwise to increase pressure and counterclockwise to decrease pressure.
- Always use the lowest pressure necessary to completely atomize the material.

NOTE: OPERATING THE SPRAYER AT HIGHER PRESSURE THAN NEEDED, WASTES MATERIAL, CAUSES EARLY TIP WEAR, AND SHORTENS SPRAYER LIFE.

- If more coverage is needed, use a larger tip rather than increasing the pressure.
- Check the spray pattern. The tip size and angle determines the pattern width and flow rate.

WARNING

FOLLOW THE "PRESSURE RELIEF PROCEDURE".

To reduce the risk of injection, never hold your hand, body, fingers or hand in a rag in front of the spray tip when cleaning or checking for a cleared tip. Always point the gun toward the ground or into a waste container when checking to see if the tip is cleared or when using a self-cleaning tip.

WARNING

When you spray into the paint bucket, always use the lowest spray pressure and maintain firm metal to metal contact between gun and container.

WARNING

To stop the unit in an emergency, turn the engine off. Then relieve the fluid pressure in the pump and hose as instructed in the **PRESSURE RELIEF PROCEDURE**.

5. WHEN SHUTTING OFF THE SPRAYER

- Whenever you stop spraying, even for a short break, follow the **PRESSURE RELIEF PROCEDURE**.
- Clean the tip & gun as recommended in the separate Gun Manual supplied with the gun.
- Flush the sprayer at the end of each work day, if the material you are spraying is water-based, or if it could harden in the sprayer overnight. See "Flushing". Use a compatible solvent to flush, then fill the pump and hoses with an oil based solvent such as mineral spirits.
- For long term shutdown or storage, refer to the "Flushing" section of this manual.

WARNING

Be sure to relieve pressure in the pump after filling with Airlessco Pump Conditioner.

AVOIDING TIP CLOGS

There is an easy way to keep the outside of the tip clean from material build up:

Every time you stop spraying, for even a minute, lock the gun and submerge it into a small bucket of thinner suitable for the material sprayed.

Thinner will dissolve the buildup of paint on the outside of tip, tip guard and gun much more effectively if the paint doesn't have time to dry out completely.

PRESSURE RELIEF PROCEDURE



IMPORTANT!

TO AVOID POSSIBLE SERIOUS BODY INJURY, ALWAYS FOLLOW THIS PROCEDURE WHENEVER THE SPRAYER IS SHUT OFF, WHEN CHECKING IT, WHEN INSTALLING, CHANGING OR CLEANING TIPS, WHENEVER YOU STOP SPRAYING, OR WHEN YOU ARE INSTRUCTED TO RELIEVE THE PRESSURE.

1. Engage the gun safety latch. Refer to the separate instruction manual provided with your gun on its safety features and how to engage safety latch.

2. Turn the unit off.

3. Disengage the gun safety latch and trigger the gun to relieve residual fluid pressure.

HOLD METAL PART OF THE GUN IN CONTACT WITH GROUNDED METAL PAIL. USE MINIMUM PRESSURE !

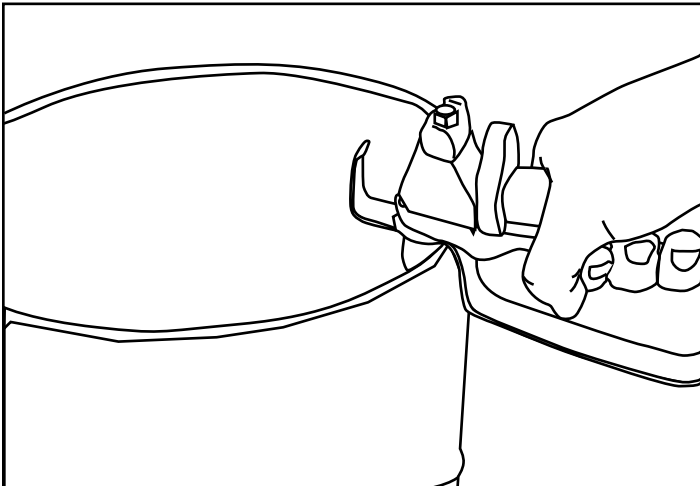

4. Turn Prime/Pressure Relief Valve (PR Valve) to the open (priming) position to relieve residual fluid pressure.

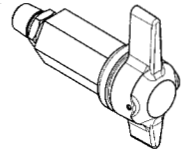

THERE WILL BE A WIDER GAP BETWEEN VALVE HANDLE AND CAM BODY WHEN IN OPEN POSITION. IN THE CLOSED POSITION THERE IS ONLY A VERY SLIGHT GAP.

NOTE: THE VALVE HANDLE CAN MOVE BOTH CLOCKWISE AND COUNTER CLOCKWISE AND CAN FACE DIFFERENT DIRECTIONS.

5. Re-engage gun safety latch and close Prime/Pressure Relief Valve.

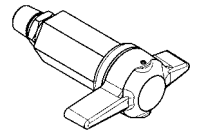

If the **SPRAY TIP OR HOSE IS CLOGGED**, follow Step 1 through 5 above. Expect paint splashing into the bucket while relieving pressure during Step 4.

If you suspect that pressure hasn't been relieved due to damaged Prime/Pressure Relief Valve or other reason, engage the gun safety latch and take your unit to an authorized Airlessco Service Center.

DAILY MAINTENANCE

1. Keep the displacement pump packing nut/wet cup lubricated with Airlessco TSO (Throat Seal Oil) at all times. The TSO helps protect the rod and the packings.
2. Inspect the packing nut daily. Your pump has a patented Triple Life Packing System. Packing life will be extended a minimum of three times if the following "Packing Adjustment" procedure is followed:

IF SEEPAGE OF PAINT INTO THE PACKING NUT AND/OR MOVEMENT OF THE PISTON UPWARD IS FOUND (WHILE NOT SPRAYING), THE PACKING NUT SHOULD BE TIGHTENED ENOUGH TO STOP LEAKAGE ONLY, BUT NOT ANY TIGHTER. OVERTIGHTENING WILL DAMAGE THE PACKINGS AND REDUCE THE PACKING LIFE.

AIRLESS SPRAY GUN OPERATION

SPRAY

Attach spray gun to airless unit and tighten fittings securely. Set the gun safety latch. (Also may be called gun safety lock, or trigger lock)

* The gun safety latch should always be set when the gun is not being triggered.

Read all warnings and safety precautions supplied with the spray gun and in product manual.

FIG. 7 GUN SAFETY LATCH IN LOCKED POSITION GUN SAFETY LATCH

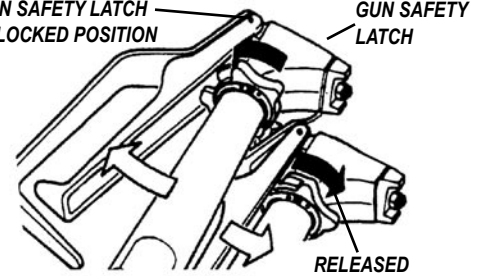

MAJOR COMPONENTS OF SPRAY GUN AND REVERSIBLE SPRAY TIP

FIG. 8

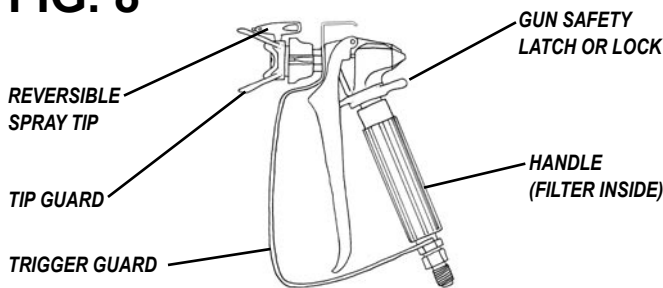
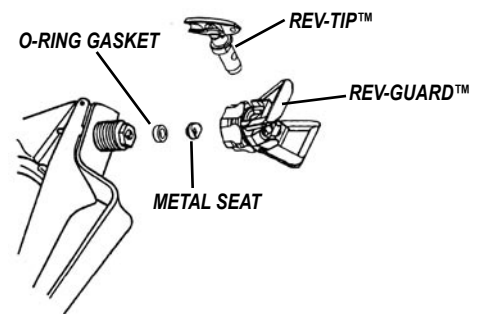

FIG. 9



SPRAY TIP ASSEMBLY

1. Be sure **PRESSURE RELIEF PROCEDURE** is followed before assembling tip and housing to the gun.
2. Lock gun safety latch.
3. Insert **REV-TIP™** cylinder into the **REV-GUARD™** (guard housing assembly).
4. Guide metal seat into **REV-GUARD™** (guard housing assembly) through retaining nut & turn until it seats against the cylinder.
5. Insert O-Ring gasket on metal seat so it fits in the grooves.
6. Finger tighten **REV-GUARD™** retaining nut on gun.
7. Turn guard in the desired position.
8. Completely tighten the retaining nut.

FIG. 10

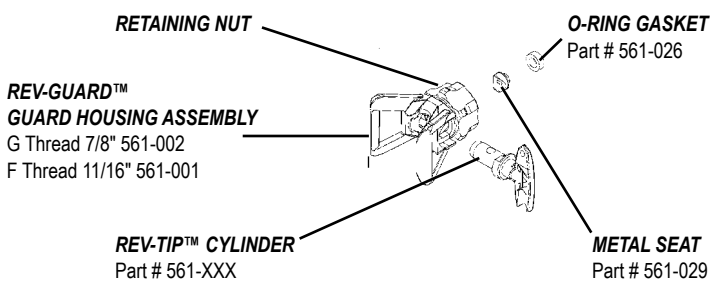

CLEANING FILTER IN GUN HANDLE

To clean the filter, use a brush dipped in an appropriate solvent. Change or clean filters at least once a day. Some types of latex may require a filter change after four hours of operation.

TO REMOVE CLOGS FROM SPRAY TIP

1. Lock gun safety latch.
2. Turn **REV-TIP™** handle 180 degrees.
3. Disengage trigger lock & trigger gun into pail.
4. If the **REV-TIP™** handle appears locked (resists turning), loosen the retaining nut. The handle will now turn easily.
5. Engage gun safety latch & return handle to the spray position.

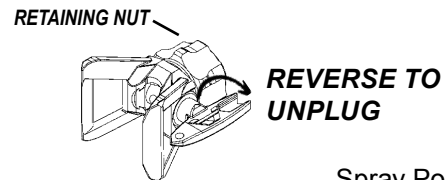

Spray Position Shown

CLOGGED FLAT TIP

Should the spray tip become clogged, relieve pressure from hose by following the **PRESSURE RELIEF PROCEDURE**. Secure gun with the safety latch, take off guard, take out the tip, soak in appropriate solvent & clean with a brush. (Do not use a needle or sharp pointed instrument to clean the tip. The tungsten carbide is brittle and can chip.)

CLEANING SPRAY GUN

Immediately after the work is finished, flush the gun out with a solvent. Brush pins with solvent and oil them lightly so they will not collect dried paint.

AIRLESS SPRAY GUN

FIG. 11

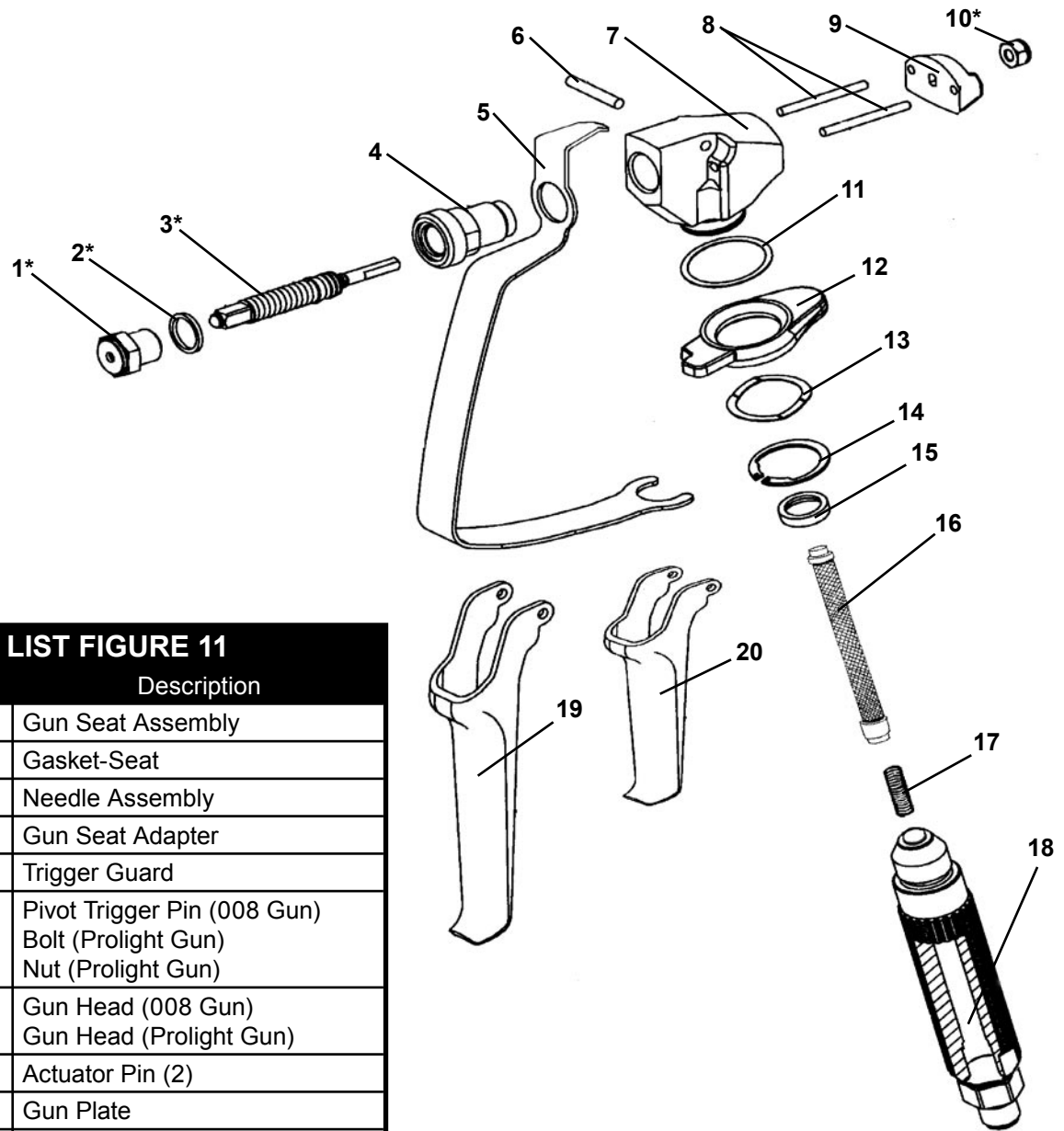

PARTS LIST FIGURE 11

Item No.	Part No.	Description
1	120-530*	Gun Seat Assembly
2	120-535*	Gasket-Seat
3	120-520*	Needle Assembly
4	120-529	Gun Seat Adapter
5	120-562	Trigger Guard
6	120-539 119-055 119-054	Pivot Trigger Pin (008 Gun) Bolt (Prolight Gun) Nut (Prolight Gun)
7	120-509 120-109	Gun Head (008 Gun) Gun Head (Prolight Gun)
8	120-540	Actuator Pin (2)
9	120-536	Gun Plate
10	120-038*	Nut
11	120-056	Plastic Washer
12	120-538	Gun Trigger Lock
13	120-055	Wave Washer
14	120-049	Retaining Ring
15	120-082	Handle Seal
16	120-090CX 120-090FX	Gun Filter-Coarse Gun Filter-Fine
17	120-088	Spring
18	120-099 120-106	Gun Handle Assy (008 Gun) Gun Handle Assy (Prolight Gun)
19	120-506 120-542	Gun Trigger (008) Gun Trigger (Prolight)
*	120-534	Gun Repair Kit

AIRLESS SPRAY TROUBLESHOOTING

DEFECTS	CAUSE	CORRECTION
Coarse spray	Low pressure	Increase the pressure
Excessive fogging (overspray)	High pressure Material too thin	Reduce the pressure to satisfactory pattern distribution Use less thinner
Pattern too wide	Spray angle too large	Use smaller spray angle tip
Pattern too narrow	Spray angle too small	Use larger spray angle tip (if coverage is OK, try tip in same nozzle group)
too much material	Nozzle too large Material too thin Pressure too high	Use smaller nozzle Reduce pressure
too little material	Nozzle too small	Use next larger nozzle Material too thick
thin distribution in center of pattern "horns"	Worn tip Wrong tip	Change to new tip Use nozzle with narrow spray angle
Thick skin of work	Material too viscous Application too heavy	Thin cautiously Reduce pressure and/or use tip in next smaller nozzle group
Coating fails to close & smooth over	Material too viscous	Thin cautiously
Spray pattern irregular, deflected	Orifice clogged Tip damaged	Clean carefully Replace with new tip
Craters or pock marks, bubbles on work	Solvent balance	Use 1 to 3% "short solvents remainder "long" solvents (this is most likely to happen with material of low viscosity, lacquers, etc.)
Clogged screens	Extraneous material in paint Course pigments Poorly milled pigments (paint pigments glocculate)	Clean screen Use coarse screen if orifice size allows. Use courser screen, larger orifice tips. Obtain ball milled paint. If thinner has been added, test to see if a cover screen. Incompatible drop placed on top of paint mixes or flattens out on the paint mixture & thinners on the surface. If not, try different thinner in fresh batch of paint.
Excess paint builds on tip guard	Spray gun too close to surface Pressure setting too high	Hold gun further from surface sprayed Reduce pressure setting
Drips, spits from tip	Valve seat and/or ball in gun head damaged or worn	Service spray gun, replace valve assembly
Tip clogs continually	Debris in paint Gun filter missing Coarse filter mesh	Thoroughly strain the paint before use Do not operate without inlet strainer

TEST THE PATTERN

GOOD, FULL **SPOTTY PATTERN, INCREASE PRESSURE**



TIP SELECTION GUIDE

Spray tip selection is based on paint viscosity, paint type, & job needs. For light viscosities (thin paints), use a smaller tip; heavier (thicker paints), use a larger tip size. Spray tip size is based on how many gallons of paint per minute can be sprayed through the tip. Do not use a tip larger than maximum pump flow rate or capacity the sprayer can accommodate. Pump flow rate is measured in gallons per minute (GPM).

TIP IDENTIFICATION:

1ST 3-DIGITS identifies it as a **REV-TIP™** for airless paint spraying (P.N. 560-xxx) or a **REV-TIP™** for airless line striping (P.N. 562-xxxST).

4TH DIGIT is the fan width - the number is half the fan width, e.g., 5 means a 10" fan.

5TH AND 6TH digits are for the orifice size and is measured in thousandths of an inch, e.g., 17 = 0.017 inch - The higher the number, the larger the tip.

REV-TIP™ for Painting Fan Width (12" from surface)		SPRAY TIP - ORIFICE SIZE (INCHES)															
in.	mm	.009	.011	.013	.015	.017	.019	.021	.023	.025	.027	.029	.031	.035	.039	.041	
4-6	102-152	209	211	213	215	217	219	221	223	225	227	229					
6-8	152-203	309	311	313	315	317	319	321	323	325	327		335				
8-10	203-254	409	411	413	415	417	419	421	423	425	427	431					
10-12	254-305		511	513	515	517	519	521	523	525	527	531	535				
12-14	305-356			613	615	617	619	621	623	625	627	631	635	639	641		
14-16	356-406				715	717		721						739	741, 754		
16-18	406-457				815		819	821				831					
20-24	508-610	NEW WIDE TIPS:						W21	W23	W25	W28	W29	W31				
Gun Filter	C=course-60 mesh F=Fine-100 mesh		F	F	F, C	C	C	C	C							REMOVE FILTER	
Wood Interior	Lacquer, Varnish, Stain, Sealer, Enamel		•	•	•												
Wood Exterior	Exterior Stain, Vinyl, Acrylic, Latex				•	•	•	•									
Masonry	Vinyl, Oil Base, Alkyd, Latex, Acrylic, Block Filler, Elastomer				•	•	•	•	•	•	•	•	•	•	•	•	
Ceiling	Hi Build, Mil White							•	•								
Structural Steel	Heavy Coatings							•	•	•	•	•	•	•	•	•	
Water Flow Rate @ 2000psi, 138 bar	(gpm) (lpm)		.12 .49	.18 .69	.24 .91	.31 1.17	.38 1.47	.47 1.79	.57 2.15	.67 2.54	.77 2.96	1.03 3.90	1.31 4.98	1.63 6.17	1.80 6.81		
Paint Flow Rate latex paint @ 2000psi, 138 bar/1.36 spec. gr.	(gpm) (lpm)		.10 .38	.15 .57	.21 .79	.27 1.02	.33 1.25	.40 1.51	.49 1.85	.58 2.20	.66 2.50	.88 3.33	1.12 4.24	1.39 5.26	1.54 5.83		
Pump Minimum Output*	(gpm) (lpm)		.25 1.0	.25 1.0	.33 1.25	.40 1.5	.50 1.9	.60 2.3	.75 2.8	.88 3.3	1.0 3.8	1.25 4.7	1.5 5.7	2.0 8.2	2.2 8.2		

*Pump will support tip worn to next larger size.

Thickness of the paint coat per stroke is determined by spray tip "fan width", rate of the spray gun movement, and distance to surface. Two tips having the same tip size, but different pattern widths will deliver the same amount of paint over a different area (wider or narrower strip). A spray tip with a narrow pattern width makes it easy to spray in tight places.

During use, especially with latex paint, high pressure will cause the orifice to grow larger. This destroys the pattern. Replace tips before they become excessively worn. Worn tips waste paint, cause overspray, make cutting-in difficult, and decreases sprayer performance.

REGULAR MAINTENANCE

1. Always stop the pump at the bottom of its stroke when you take a break or at the end of the day. This helps keep material from drying on the rod, damaging the packings.
2. Keep the displacement pump packing nut/wet cup 1/3 full of Airlessco Throat Seal Oil at all times. The TSO helps protect the packings and rod.
3. Lubricate Connecting Rod Pin every 3 months.
4. Inspect the packing nut daily. Your paint pump has Airlessco's patented "Triple Life Packing System". Packing life will be extended a minimum of 3 times if the proper packing tightening procedure is followed!

PACKING TIGHTENING PROCEDURE:

Inspect the packing nut daily! If seepage of paint into the packing nut and/ or movement of the piston upward is found (while not spraying), the packing nut should be tightened enough to stop leakage only, but not any tighter.

OVERTIGHTENING WILL DAMAGE THE PACKINGS and reduce the packing life to the life of other piston pumps.

OIL AND LUBRICATION INSTRUCTIONS

FIG. 12

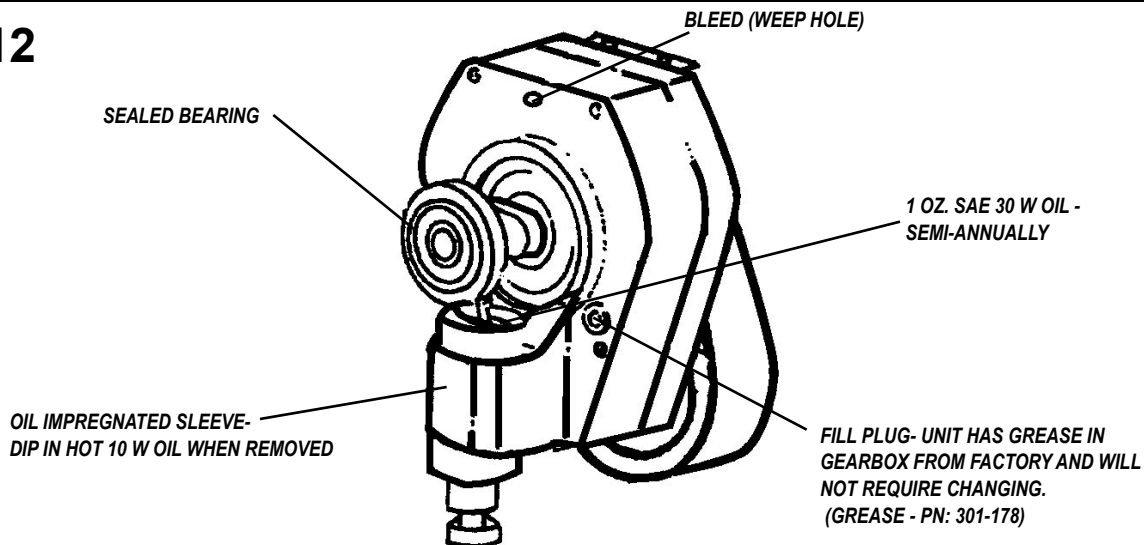

ELECTRIC MOTOR MAINTENANCE

1. **LUBRICATION** - This motor is supplied with pre-lubricated ball bearings, lubricated for the life of the bearing.
2. **MOTOR BRUSHES** - need periodic inspection and replacement as wear indicates. Brush wear is greatly influenced by individual application. It is recommended that brush wear be checked at early intervals of operation in order to determine future required inspection. Standard Leeson brushes have an initial length of 1 and 1/4". When the brushes are worn to a length of 5/8" they should be replaced.

TO CHANGE THE BRUSHES:

1. Unplug the machine.
2. Remove the cover over the motor.
3. Open the two covers at the rear of the motor.
4. Loosen the screw under the brush.
5. Pull out the wire.
6. Push the brush retainer clip in and withdraw.
7. Remove the worn brushes.
8. Install new brushes in the reverse order.

For long life, new brushes (Part # 301-146 for 110 volt, Part # 301-147 for 220 - 240 volts) need to have a run in period. After changing brushes, set the machine for spraying. With a bucket of Pump Conditioner and water, a 50' 1/4" airless hose, airless gun and tip on unit, open the prime valve and switch on. The pump will now prime. With pump running in the prime mode, turn the pressure control knob to high pressure. (The pump has to cycle fast with no pressure in the pump). Run the pump for 20 minutes and the brushes will be run in.

FIELD TROUBLESHOOTING

PROBLEM	CAUSE	SOLUTION
Unit doesn't prime	Airleak due to: <ul style="list-style-type: none"> • Loose suction nut • Worn o-rings Stuck or fouled balls Prime/Pressure Relief valve not opening	<ul style="list-style-type: none"> • tighten suction nut • replace o-ring (106-018) on suction seat & o-ring (106-017) below suction seat • service inlet and outlet valves • clean or replace Prime Valve (100-180)
Unit primes but has poor or no pressure	Pressure set too low Filter(s) are clogged Outlet valve fouled/worn Prime/pressure relief valve bypassing Packings and/or piston worn	<ul style="list-style-type: none"> • turn up pressure • clean or replace gun filter, inlet filter, and/or manifold filter • service outlet valve • clean or replace prime valve (100-180) • tighten packing nut • repack unit
Unit does not maintain good spraying pressure	Blown spray tip Packings and/or pistons worn Upper seat worn	<ul style="list-style-type: none"> • replace spray tip • repack unit • replace upper seat
Unit does not run.		• see electrical troubleshooting

REPLACEMENT OF BELT/BELT ADJUSTMENT

NOTE: The Cog Belt System does not require alignment. When upper sheave is placed on motor shaft it is pushed on until a positive stop is reached. The set screws (Fig. 26, Item 50) are then loctited. The lower pulley is placed on gearbox and held in place with keyway and snap ring (Fig. 26, Item 23) The flange on upper sheave holds the belt in alignment and the belt self aligns on lower pulley eliminating having to align.

FIG. 13

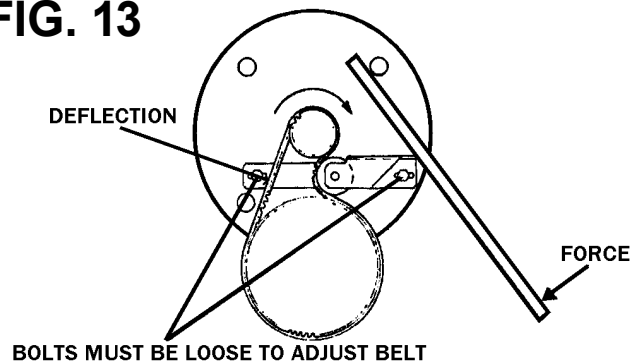

REPLACEMENT OF BELT

1. Remove cover (Fig. 26, Item 42) from unit.
2. Remove Tensioner Assembly (Fig 26). Then loosen screws (Fig. 26, Item 53). Move gearbox forward to allow removal and replacement of belt.
3. Retighten screws into gearbox until they bottom out. (Fig. 26, Item 53) This will align gearbox correctly.
4. Replace tensioner with bolts and leave loose to allow adjusting belt tension.
5. Tighten belt as shown in Figure 13. When properly tightened the deflection play should be 1/4 inch when pushing hard with thumb. (20 ft/lbs)

NOTE: WHEN PLACING BELT ON PULLEYS AND INSERTING THE TENSIONER AGAINST BELT, ENSURE COGS ON BELT ARE ENGAGED INTO COGS ON PULLEYS BEFORE TIGHTENING BELTS. ROTATING UPPER PULLEY WHILE HOLDING THE TENSIONER AGAINST THE BELT WILL ALLOW PROPER ENGAGEMENT OF COGS PRIOR TO TIGHTENING.

SERVICING THE FLUID PUMP

NOTE: CHECK EVERYTHING IN THE TROUBLESHOOTING CHART BEFORE DISASSEMBLING THE SPRAYER.

FLUID PUMP DISCONNECT

1. Flush out the material you are spraying, if possible.
2. Follow the Pressure Relief Procedure on page 8. Stop the pump in the middle of down stroke.
3. Remove the suction tube and fluid hose (if so equipped) from the fluid pump.
4. Remove the connecting rod shield from the pump.
5. Remove 2 retaining rings and slip the sleeve of the coupling down and remove both coupling halves. This will disconnect fluid pump from the connecting rod.
6. Using a 7/8" box wrench, disconnect the high pressure fluid line from the pump.
7. Using a 9/16" wrench, unscrew the two tie rod locknuts.
8. Pull the pump off the tie rods.

FIG. 14

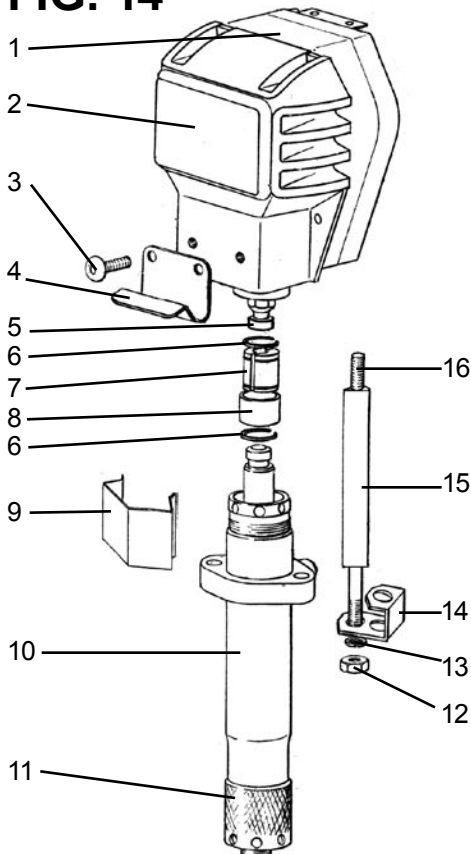

FLUID PUMP REINSTALL

1. Loosen the packing nut & extend piston rod to fully up position. Slip sleeve over the piston rod. See figure 15.
2. Insert one of the retaining rings through the packing nut and rest the sleeve on top of it. See figure 16 & 17.
3. Connect the connecting rod with the fluid pump by installing the coupling halves. Slide sleeve over the coupling halves and secure with retaining ring. See figure 18.
4. Remove the retaining ring from the packing nut and insert into coupling halves. See figure 19
5. Secure the fluid pump housing to the tie rods and screw locknuts with washers on loosely.
6. Tighten the tie rod locknuts evenly to 30 ft. lb.
NOTE: AFTER ALL THE ROD LOCKNUTS ARE TIGHT, THE ALIGNMENT OF BOTH RODS SHOULD ALLOW EASY ASSEMBLY AND DISASSEMBLY OF THE COUPLING. IF ANY BINDING, LOOSEN AND RETIGHTEN ALL THE ROD LOCKNUTS TO IMPROVE THE ALIGNMENT. MISALIGNMENT CAUSES PREMATURE WEAR OF SEAL AND PACKINGS.
7. Tighten packing nut clockwise until resistance against the packings can be felt. Turn it one full turn more.
8. Start the pump and operate it slowly (at low engine speed) to check the piston rod for binding. Adjust tie rod lock nuts if necessary to eliminate binding.
9. Prime the unit and run at maximum pressure for several minutes, then release the pressure & repeat step 7.
10. Fill the wet cup (packing nut) with five drops of TSO (Throat Seal Oil).

PARTS LIST FIGURE 14

Item No.	Part No.	Description
1	301-203-99	Gearbox 3/4" (810/910E)
	301-204-99	Gearbox 1" (1100/1110E)
2	301-320	Cover
3	100-360	Screw
4	301-105	Hook
5	301-046	Rod End
6	189-048	Retaining Ring
7	189-046	Coupling Set
8	198-047	Retaining Sleeve
9	301-467	Front Shield
10	187-410	SL Paint Pump Assy
11	187-002	Suction Nut
12	140-051	Nut (2)
13	140-035	Lock Washer (2)
14	301-173	Bracket-Return Tube
15	301-059	Spacer (2)
16	100-328	Stud (2)

FIG. 15

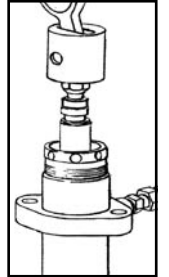

FIG. 16

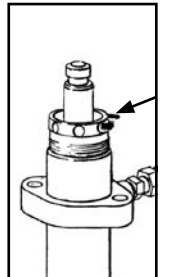

FIG. 17

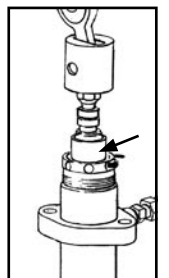

FIG. 18

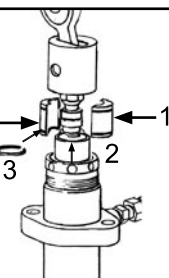
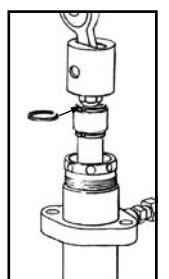

FIG. 19



SERVICING INLET NUT & OUTLET VALVE

INLET VALVE

1. Using the rod collar tool (189-211), unscrew the suction nut, containing suction seat support, off of the fluid body.
2. Remove the suction seat, O-ring, suction ball and suction ball guide with O-ring.
3. Clean all parts and inspect them for wear or damage, replacing parts as needed. Old O-rings should be replaced with new ones.

***NOTE: SUCTION SEAT (187-065) IS REVERSIBLE.**

PISTON OUTLET VALVE

1. Place piston holder in a vise. Slide the piston into the holder & lock in place with the 1/4" dowel.
2. Use a 3/8" allen wrench to unscrew the outlet seat support from the piston.
3. Remove the outlet seat, O-ring, outlet ball and ball guide.
4. Inspect the outlet ball and seat for wear. Replace as required.

***NOTE: OUTLET SEAT (187-061) IS REVERSIBLE.**

5. While piston is still locked in the holder, install parts back into the piston in the following order: ball guide, ball, O-ring, outlet seat. Before reinstalling the outlet seat support apply two drops of Loctite No. 242 (blue) on the threads and torque to 20 ft-lbs.

PARTS LIST FIGURE 20 & 21

Item No.	Part No.	Description
1	187-020	Ball
2	187-014	O-Ring
3	187-065	Seat
4	187-016	Retainer
5	187-002	Nut
6	187-330-99	Piston Rod
7	187-062	Ball Guide
8	115-022	Outlet Ball
9	106-021*	O-Ring
10	187-061	Outlet Seat
11	187-051*	Outlet Seat Support

FIG. 20

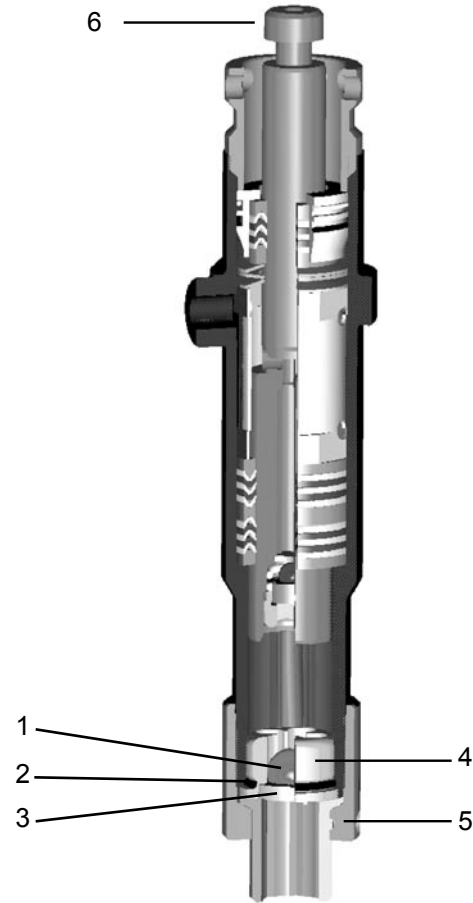
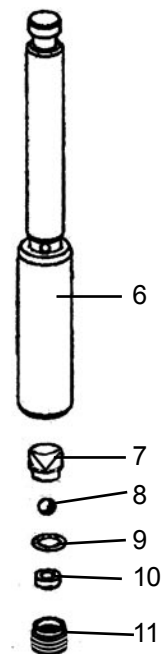

FIG. 21



PACKING REPLACEMENT PROCEDURES

DISASSEMBLY OF THE FLUID PUMP

1. Unscrew & remove the packing nut.
2. Push the piston rod down through the packings & out of the pump.
3. Now push the packing removal tool up through the pump & remove from the top bringing the packings, spacer & springs along with it, leaving the fluid body empty.











***NOTE: MAKE SURE ALL PACKINGS & GLANDS HAVE BEEN REMOVED FROM THE FLUID PUMP.**

4. Clean inside of fluid body.
5. Disassemble all parts & clean for reassembly. Discard any old packings. Save the metal upper glands. Replace metal lower glands with new metal glands from the packing kit.

*** NOTE: IF THE OLD PACKING HAD A METAL GLAND FOR (187-058), DISCARD & REPLACE WITH A NEW PLASTIC ONE FROM PACKING KIT.**

6. Lubricate leather packing in lightweight oil for 10 minutes prior to reassembly.

REASSEMBLY

1. Take the lower metal male gland and place it down on the flat side. 
2. Take three of the lower polyethylene V-packings and two of the leather V-packings and place onto your male gland in the following order with the inverted side down:  polyethylene, leather, polyethylene, leather, polyethylene.
3. Take the female adaptor, which is inverted on both sides,  and place it on top of your assembled lower packings.
4. Follow step 2 above but with packings inverted side up. 
5. Take the second lower male gland and place it on top of your assembled packings with the rounded side down. 
6. Take your assembled glands & packings (13 pieces all together) and slide on to the lower half of the piston.
7. Take the spacer and slide over the top of the piston (it doesn't matter which direction it sits), falling onto the lower packings.
8. Take the three Belleville Springs and slide over the top of the piston in the following order:
 - * First spring, curve facing down 
 - * Second spring, curve facing up 
 - * Third spring, curve facing down 
9. Take the upper male gland and place it with the rounded side up. 
10. Take the three upper polyethylene V-packings and two leather packings and assemble with the inverted side down,  on to the male gland in the following order: polyethylene, leather, polyethylene, leather, polyethylene.

11. Take the upper female gland & place on top of your assembled upper packings with the inverted side down. 
12. Take your assembled upper glands and packings (7 pieces) and slide on over the top of the piston, making sure the inverted sides are facing down.
13. Take the V-packing holder and replace the white O-ring and the black O-ring with new ones from the packing kit.
14. Slide the V-packing holder over the top of the upper packings so they fit inside.
15. Lubricate the inside of the fluid pump body and the outside of the packings with a light weight oil.
16. Slide the completed assembly into the fluid pump body. ***NOTE: TO KEEP PACKINGS SECURED IN THE CORRECT POSITION, HOLD THE PUMP BODY UPSIDE DOWN AND PUSH THE COMPLETED ASSEMBLY UPWARDS INTO THE PUMP BODY. ONCE PLACED INSIDE, TILT THE PUMP BODY BACK UP TO KEEP ALL PIECES.**
17. Thread the packing nut into the top of the fluid body and tighten hand tight.
18. Take the suction retainer and replace the black O-ring with a new one from the packing kit. Replace the suction ball with the new one from the kit into the suction retainer. Place the suction seat into the flat side of the ball guide, over the suction ball. Now place the white O-ring into the groove around the suction seat.
19. Take the completed suction valve assembly and place it into the bottom of the fluid body, with the rounded side fitting inside.
20. Take the suction seat support and place the flat side down on to the suction valve assembly (threads will be facing upwards).
21. Thread the suction nut, over the suction seat support.
22. Tighten the packing nut (utilizing the packing nut adjustment tool) clockwise one full turn.

PACKING REPLACEMENT PROCEDURES

FIG. 22

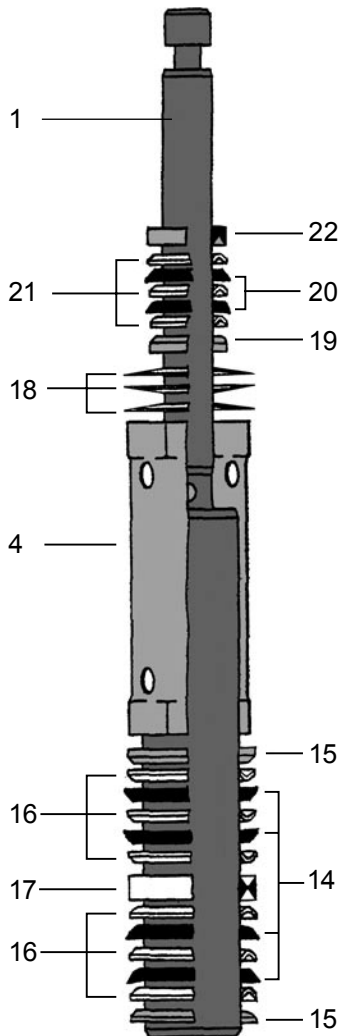
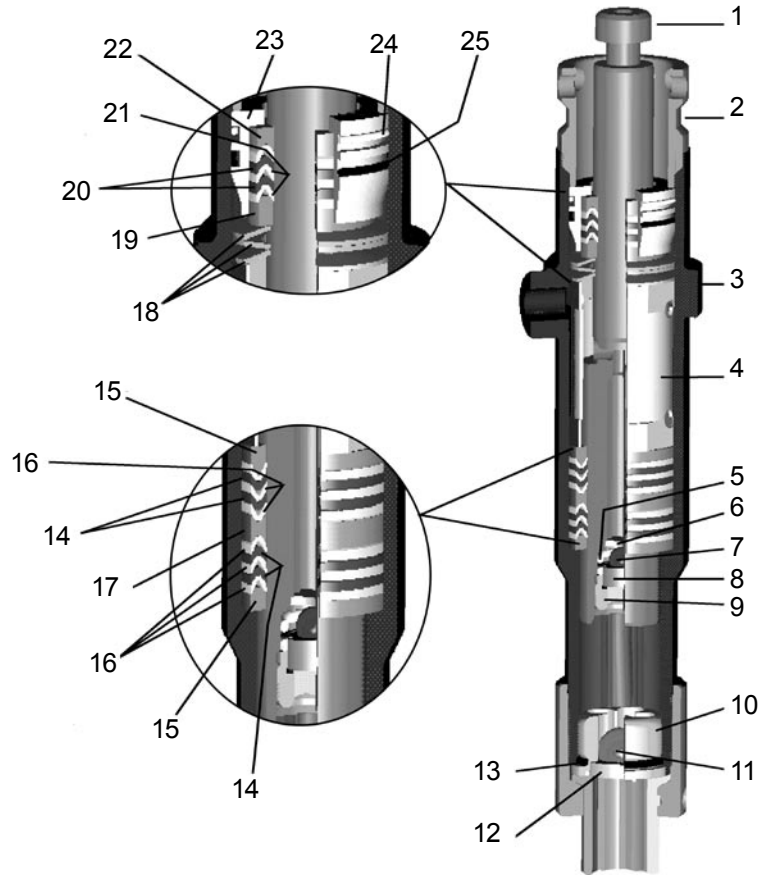

FIG. 23



PARTS LIST FIGURE 22 & 23

Item No.	Part No.	Description
1	187-330-99	Piston Rod
2	187-046	Packing Nut
3	187-313	Fluid Body
4	187-315	Spacer
5	106-021	O-Ring
6	187-062	Ball Guide
7	115-022	Outlet Ball
8	187-061	Outlet Seat
9	187-051	Outlet Seat Support
10	187-016	Suction Retainer
11	187-020	Suction Ball
12	187-065	Suction Seat
13	106-014	O-Ring

PARTS LIST FIGURE 22 & 23

Item No.	Part No.	Description
14	187-059	Packing Leather
15	187-037	Male Gland
16	187-029	Packing Polyethylene
17	187-058	Female Adaptor
18	187-031	Belleville Springs
19	187-025	Male Gland
20	187-060	Packing Leather
21	187-030	Packing Polyethylene
22	187-026	Female Gland
23	187-047	Packing Holder
24	106-012	White O-Ring
25	106-013	Black O-Ring

PAINT SYSTEM

FIG. 24

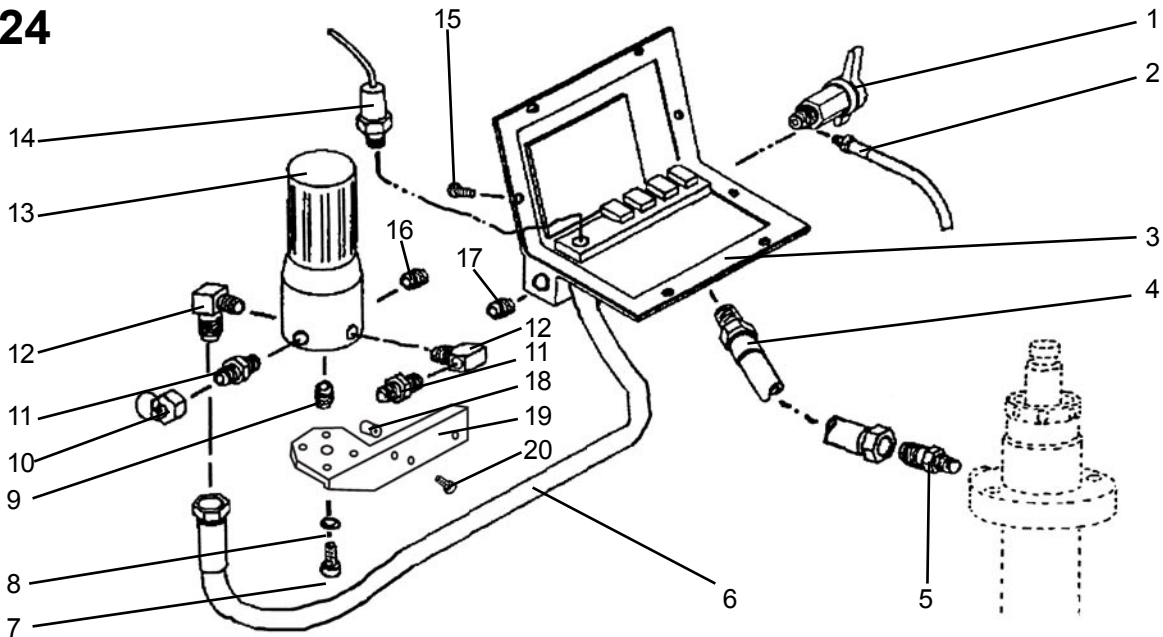

PARTS LIST FIGURE 24		
Item No.	Part No.	Description
1	100-180	Prime Valve
2	301-348	Bypass Tube
3	301-318-99	Pressure Control Assy (110V)
	301-364-99	Pressure Control Assy (230V)
4	301-308	Hose
5	169-010	Nipple
6	100-123	Hose
7	100-312	Screw
8	331-103	Washer
9	100-028	Plug (1/4")
10	100-160	Cap Plug Set

PARTS LIST FIGURE 24		
Item No.	Part No.	Description
11	100-109	Nipple (3/8"-1/4")
12	169-013	Elbow
13	111-200	Manifold Filter
14	331-249-99	Sensor
15	111-034	Screw (8)
16	100-329	Plug (3/8")
17	100-028	Plug (1/4")
18	301-290	Spacer
19	305-140	Filter Bracket
20	100-371	Screw

MANIFOLD FILTER (111-200-99)

FIG. 25

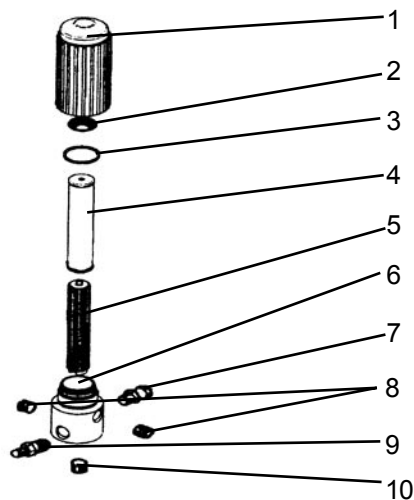

PARTS LIST FIGURE 25		
Item No.	Part No.	Description
1	111-202	Base
2	301-356	Spring
3	106-007	O-Ring
4	111-204	Filter 60 Mesh
5	111-203	Support
6	111-201	Base
7	100-159	Swivel
8	100-129	Plug 3/8" (2)
9	100-109	Nipple 3/8"M x 1/4"M
10	100-028	Plug 1/4"

COMPLETE SPRAYER

FIG. 26

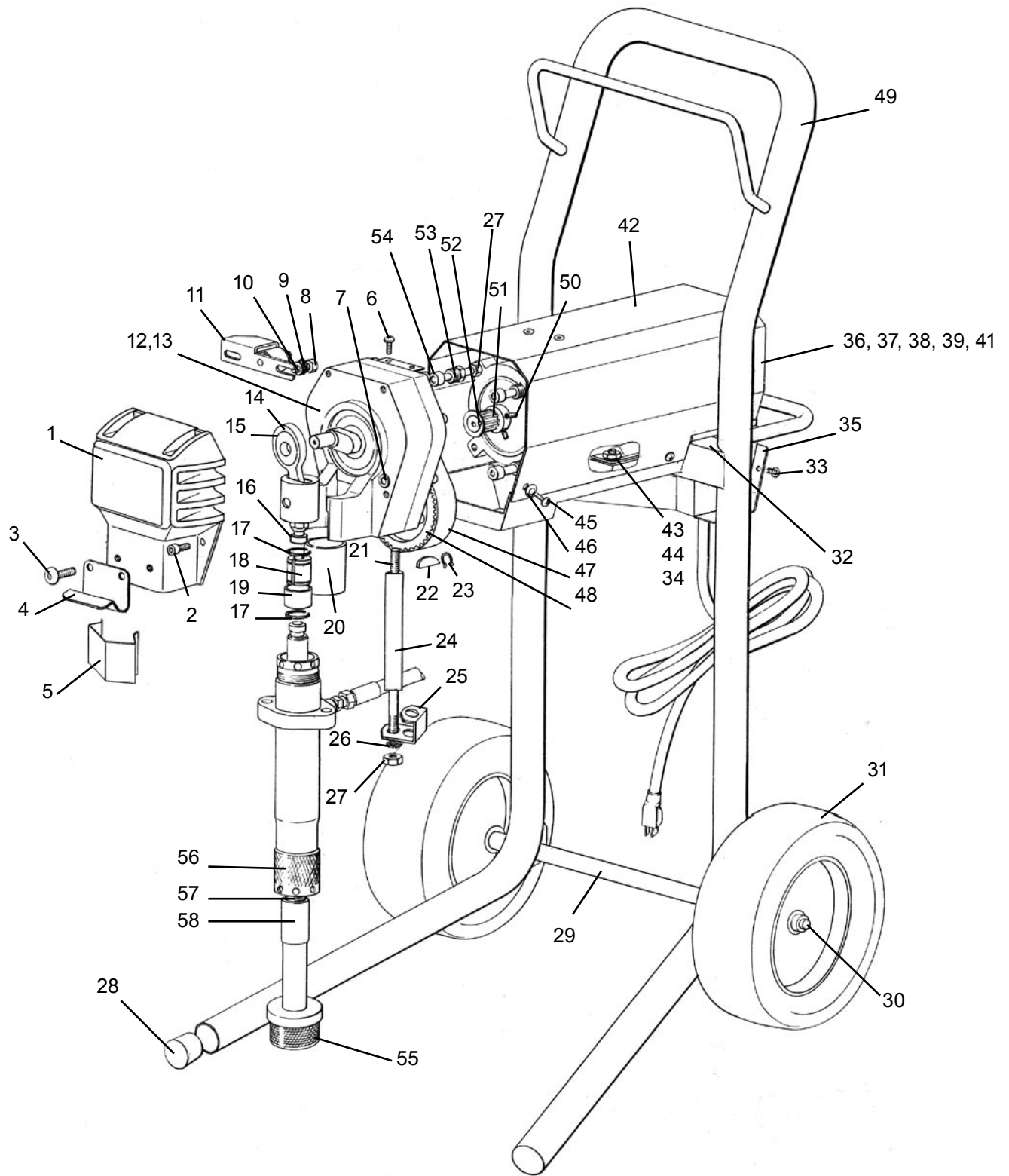

COMPLETE SPRAYER PARTS LIST

PARTS LIST FIGURE 26

Item No.	Part No.	Description
1	301-320	Cover
2	100-312	Screw (4)
3	100-360	Screw (2)
4	301-105	Hook
5	301-467	Front Shield
6	301-337	Screw (2)
7	100-028	Plug 1/4 NPT
8	111-044	Screw (2)
9	113-023	Lock Washer (2)
10	100-344	Washer (2)
11	301-193	Tensioner Assembly
12	301-203-99	Gearbox 3/4" (810/910E)
13	301-204-99	Gearbox 1" (1100/1110E)
14	301-333	Connecting Rod Assy (1100/1110E)
15	301-291	Connection Rod Assy (810/910E)
16	301-046	Rod End
17	189-048	Retaining Ring (2)
18	189-046	Coupling Set
19	189-047	Retaining Sleeve
20	301-047	Sleeve Bearing
21	100-328	Stud (2)
22	301-139	Woodruff Key
23	100-332	Retaining Ring
24	301-059	Spacer (2)
25	301-173	Bracket-Return Tube
26	140-035	Lock Washer (2)
27	140-051	Nut (2)
28	301-134	Stopper (2)

PARTS LIST FIGURE 26 CONT

Item No.	Part No.	Description
29	113-056	Axel
30	143-029	Set Collar (2)
31	301-165	Wheel (2)
32	301-316	Rubber Edge 1.17' (makes 2)
33	111-037	Screw (4)
34	140-029	Washer
35	101-060	High Voltage Label
36	301-190	Fan
37	301-191	Retaining Clip Fan
38	117-052	Screw (3)
39	301-106A	1.25HP Motor
41	301-089	Fan Cover
42	301-321	Cover
43	113-022	Nut (4)
44	113-023	Lock Washer (4)
45	111-037	Screw (4)
46	301-135	Grommet (6)
47	301-231	Cog Belt
48	301-237	Cog Pully
49	301-206	Frame
50	100-387	Set Screw (2)
51	301-233	Sheave
52	112-029	Key
53	301-099	Retainer (3)
54	301-044	Screw (3)
55	141-010	Inlet Strainer
56	187-002	Suction Nut
57	187-001	Suction Fitting
58	301-004	Suction Tube

Replacement Label Kits

Part No.	Description
301-430	Airlessco SL810
301-435	Allpro 910E
301-431	Airlessco SL1100
301-436	Allpro 1110E
101-232	Decal, Center Stripe

SUCTION ASSY - 5 GAL. - (301-090-99)

FIG. 27

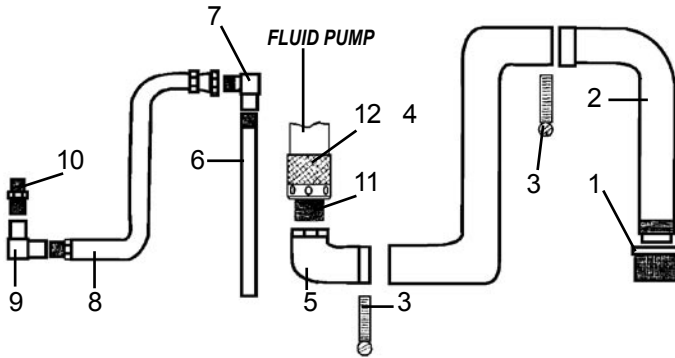

PARTS LIST FIGURE 27

Item No.	Part No.	Description
*	301-517-99	Suction Hose Assy (includes items 1-5)
1	141-008	Inlet Strainer
2	301-514	Suction Tube
3	301-516	Hose Clamps (2)
4	301-513A	Hose
5	100-165	Elbow
6	188-377	Return Pipe
7	100-128	Elbow
8	100-012	Whip
9	100-126	Elbow**
10	100-385	Reducer**
11	187-017	Fitting
12	187-018	Suction Nut

SUCTION ASSY - 55 GAL. - (301-543-99)

FIG. 28

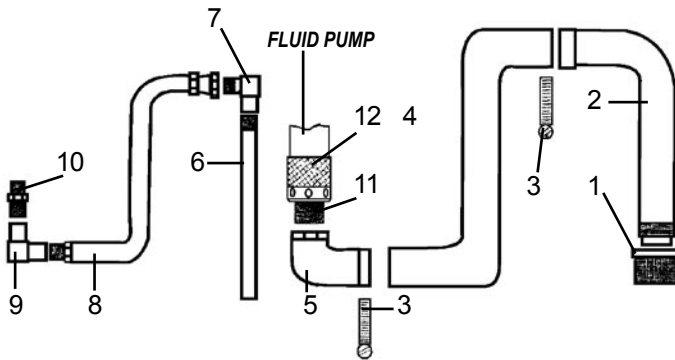

PARTS LIST FIGURE 28

Item No.	Part No.	Description
1	141-008	Inlet Strainer
2	301-545	Suction Tube
3	301-516	Hose Clamps (2)
4	301-544	Hose
5	100-165	Elbow
6	188-377	Return Pipe
7	100-128	Elbow
8	100-012	Whip
9	100-126	Elbow**
10	100-385	Reducer**
11	187-017	Fitting
12	187-018	Suction Nut

TROUBLESHOOTING - MACHINE DOES NOT START

Cause	Steps
Control Settings	STEP 1: After making sure that the machine is plugged into the wall, verify that the on-off switch is in the ON position and that the pressure control knob is turned all the way to the right (clockwise for maximum pressure).
Circuit Breaker	STEP 2: Using your multi-meter, test the breaker for continuity or replace with a new breaker. If the breaker reads good, move on to step three.
Power Source	STEP 3: Using a Phillips Head screwdriver, remove the eight screws holding the pressure control assembly. Locate the red light on the board indicating that there is power. If the light is OFF proceed to step four. If the light is ON go to step six.
Power Source	STEP 4: Locate the L1 and L2 terminals on the board, and then using your multi-meter check to make sure you have 110 volts AC across the two terminals (the cord wires will still be attached). If there is no voltage at these leads, there is no power getting to the machine. Check your power source (outlet, circuit breaker, extension cord, and power cord). If you have AC voltage at the L1 and L2 terminals, go to step 5.
Thermal Overload	STEP 5: Disconnect the two red motor leads (S1 & S2) and test for continuity between them. No continuity means that the thermal coupler has opened due to excessive motor heat. If the motor is still hot to the touch, allow it to cool and then retest. If the motor is cool and there is not continuity on the red leads, contact Airlessco Technical Support to repair/replace the thermal coupler. Continuity shows that the motor's thermal coupler has not tripped. Proceed to step six.
Pressure Control Assembly (Board)	STEP 6: If everything checks out in steps one through five and the power indicating light is still out, replace the pressure control assembly.
Motor	STEP 7: Remove the motor brush covers and turn the machine on. Set the potentiometer (POT) at maximum pressure and check for DC voltage across both brush terminals. You should read greater than 80 volts DC. IF YOU DO NOT HAVE DC VOLTAGE GO TO STEP EIGHT. If you have DC voltage, turn the machine off and unplug it from the wall. Check to make sure that the brushes are making good contact with the armature. Replace the brushes if they are less than 5/8" long. If the brushes are good, replace the motor.
Sensor	STEP 8: Plug another sensor into the board and perform the zero calibration procedure. If the machine starts to run, the sensor was bad. If there is no replacement sensor available, use a multi-meter to test the resistance across the red and black wires of the sensor (be sure to test at the plug). You should read 1.5 - 3.5k ohms. A faulty sensor usually reads no continuity (open). If the sensor passes all the tests move to step nine.
Pressure Control Knob (Potentiometer)	STEP 9: Plug another potentiometer (POT) into the control board. If the machine starts, the old POT is bad. When a replacement POT is not available, remove the POT lead (with the machine turned off) from the control board and test the resistance between the red and black wires (be sure to test at the plug). The resistance should read between 8-12k ohms if it is outside of this range replace the POT.
Pressure Control Assembly (Board)	STEP 10: If you have DC voltage at the motor brushes and all of the components check out fine in steps eight and nine, replace the pressure control assembly.

PRESSURE CONTROL ASS'Y CALIBRATION

NOTE: ANYTIME A SENSOR OR PRESSURE CONTROL ASSEMBLY (BOARD) OR BOTH ARE REPLACED, THE FOLLOWING CALIBRATIONS MUST BE PERFORMED.

NOTE: PRESSURE CONTROL ASSEMBLIES (BOARDS) ARE NOW BEING EQUIPPED WITH A GREEN GROUNDING WIRE ATTACHED. CONTACT THE GROUNDING WIRE TO TERMINAL BOX USING THE SAME SCREW THAT HOLDS THE GROUNDING WIRE FROM THE POWER CORD.

1. ZERO CALIBRATION

1. Place prime/pressure relief valve in the prime (open) position.
2. Set the pressure control knob to the minimum setting (CCW).
3. Remove the screws and lower the pressure control assembly.
4. Remove any jumper on the "P-ZR" terminal. Note: This Jumper is no longer used.
5. Turn machine "ON" and ensure it is not cycling.
6. If the yellow light on the electrical board is ON and you have "0000" on the LCD display, the Zero Calibration is complete no further adjustment is necessary. If the light is ON and there are numbers on the display, use an insulated screwdriver to turn the "ZERO" trimpot counter-clockwise until the light goes out. Then turn it clockwise until the yellow light comes on, continue to turn the trimpot and the numbers will reduce until the LCD shows "0000." The Zero Calibration is now complete. If you adjust beyond "0000" the numbers will start to increase.

If the digital display shows "- -" and no yellow light, you should turn the Zero trimpot clockwise until the yellow light is on, continue turning until "0000" is shown.

The goal is to see "0000" on the digital display, this is when you have Zero Calibration. Relying on the yellow light is no longer used.

2. PRESSURE CALIBRATION

1. Complete the ZERO calibration, as per "ZERO CALIBRATION" prior to commencing this calibration.
2. Attach a 50', 1/4" airless hose, airless gun with 0.017 tip and a 5000 psi glycerin filled pressure gauge to pump.
3. Place the suction tube into a bucket of Coro-chek and water.
4. Turn prime/pressure relief valve to the prime (open) position.
5. Turn pressure control knob clockwise until machine starts to prime.
6. Place the prime/pressure relief valve in the pressure (closed) position.
7. While watching pressure gauge, slowly adjust the pressure trimpot (clockwise to increase and counter clockwise to decrease) until the maximum static pressure is 3000 psi, with the pressure control knob fully clockwise. Trigger the gun several times to ensure pressure returns to 3000 psi .

3. LCD DISPLAY CALIBRATION

IF SO EQUIPED

1. Complete the "ZERO CALIBRATION" and "PRESSURE CALIBRATION" procedures prior to commencing this calibration.
2. Turn pressure control knob up until system pressure is above 2500 psi (as indicated on glycerin filled pressure gauge) and the machine is not cycling.
3. Use an insulated screwdriver to adjust the Set trimpot. Turn trimpot CCW until it clicks, then adjust to match pressure against pressure gauge reading.
4. Move the pressure control knob to different settings and trigger the gun several times to ensure that the LCD continues to match the pressure gauge reading.

4. PASE LIMIT CALIBRATION

FORMERLY KNOWN AS THE LOW VOLTAGE OR MASTER VOLTAGE CALIBRATION

1. Attach a 50', 1/4" airless hose, airless gun with .017 tip and a 5000 psi glycerin filled pressure gauge to the pump.
2. Place the suction tube into a bucket of anti-freeze and water.
3. Turn pump on and turn up pressure control until the machine starts to prime.
4. Place the prime/pressure relief valve in the pressure (closed) position.
5. Pressurize pump to 600 psi.
6. Trigger the gun several times noting the deadband (the amount of pressure drop before the pump rebuilds to set pressure).
7. If deadband is greater than 150 psi, adjust the phase limit trimpot so that the deadband is less than 150 psi and the pressure increase after the gun trigger is released is less than 250 psi. These pressures are guidelines and may vary slightly from pump to pump.
8. Reattach pressure control assembly to unit.

ELECTRICAL SYSTEM

FIG. 29

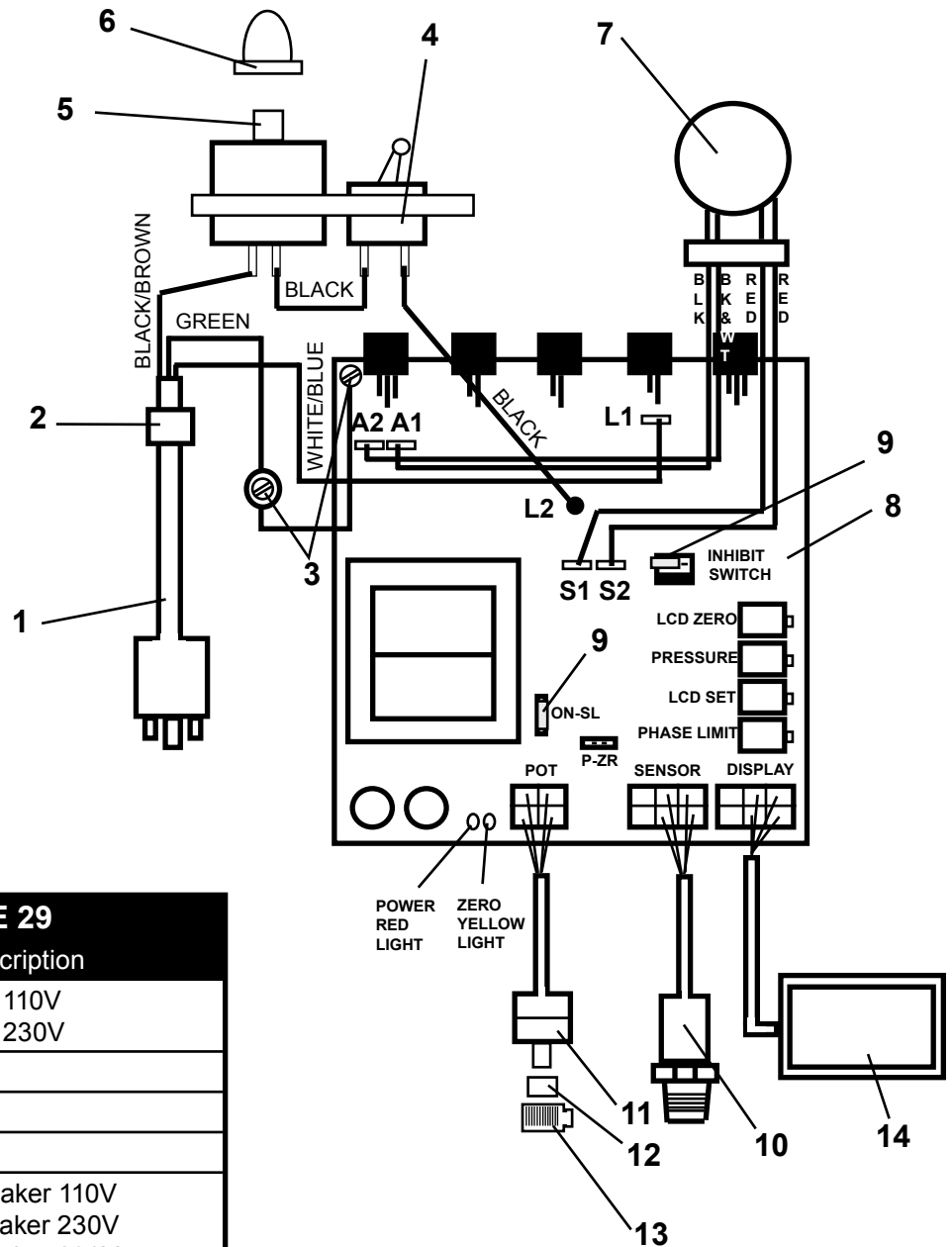

PARTS LIST FIGURE 29

Item No.	Part No.	Description
1	331-168	Electrical Cord 110V
	301-101	Electrical Cord 230V
2	331-185	Strain Relief
3	331-138	Screw
4	301-083	Toggle Switch
5	301-518	35A Circuit Breaker 110V
	301-084A	10A Circuit Breaker 230V
	301-084B	15A Circuit Breaker 230V
6	117-035	Rubber Boot
7	301-058A	1HPDC Motor 230V (810/910)
	301-106A	1.25HP Motor 110V
	301-255A	1.25HPDC Motor 230V (1100/1110E)
8	301-318-99	Pressure Control Assy 110V
	301-364-99	Pressure Control Assy 230V
9	117-207	Jumper (2)
10	331-294-99	Sensor
11	331-297	Potentiometer
12	331-184	Spacer
13	117-044	Knob
14	331-377	LCD Display (PSI)
	301-397	LCD Display (BAR)

REPLACEMENT OF ELECTRICAL COMPONENTS

WARNING: ALWAYS UNPLUG THE ELECTRICAL CORD BEFORE SERVICING MACHINE!

NOTE: ANYTIME THE PRESSURE CONTROL ASSEMBLY, SENSOR, OR BOTH ARE REPLACED, PERFORM THE CALIBRATIONS.

PRESSURE CONTROL ASSEMBLY (ELECTRICAL CONTROL BOARD)

1. Unplug machine's power cord.
2. Remove eight screws and lower the pressure control assembly.
3. Disconnect all leads from pressure control assembly.
4. Reassemble in reverse order.

SENSOR

1. Remove the screws and lower the pressure control assembly.
2. Disconnect sensor lead from the board.
3. Unscrew sensor from pressure control assembly using a 7/8" wrench.
4. Reassemble in reverse order. Use telfon tape on the sensor threads prior to reinstalling it into the pressure control assembly.

POTENTIOMETER

1. Lower pressure control assembly as described above.
2. Disconnect potentiometer lead from pressure control assembly.
3. Use a 1/16" allen wrench, loosen set screw in the potentiometer knob and remove knob and spacer.
4. Using a 1/2" wrench or deep socket, remove the nut from the potentiometer shaft assembly.
5. Pull entire potentiometer assembly out of the frame.
6. Replace in reverse order.

ON-OFF TOGGLE SWITCH

1. Lower the pressure control assembly as described above.
2. Disconnect the two wires on the toggle switch.
3. Use a 9/16" wrench to loosen the nut on the toggle switch shaft.
4. Reassemble in reverse order.

CIRCUIT BREAKER

1. Lower pressure control assembly as described above.
2. Disconnect the two wires on breaker.
3. Unscrew rubber boot from breaker shaft.
4. Use 1/2" wrench to remove the bushing from the breaker shaft.
5. Remove breaker from frame.

LIQUID CRYSTAL DISPLAY (LCD)

1. Ensure that the power switch is OFF and that the machine is unplugged.
2. Detach the pressure control assembly from the frame by unscrewing the eight screws.
3. Disconnect the LCD lead from the the pressure control assembly.
4. Separate the LCD assembly from the frame by undoing the four screws.
5. Disassemble Items 1-6.
6. Remove and replace LCD Display.
7. Reassemble in reverse order.

NOTE: DO NOT OVER TIGHTEN THE SCREW AND NUTS (ITEM 1 & 6). THIS CAN WARP THE LCD AND DAMAGE IT.

8. Perform "LCD Calibration Procedure". See page 26.

FIGURE 30

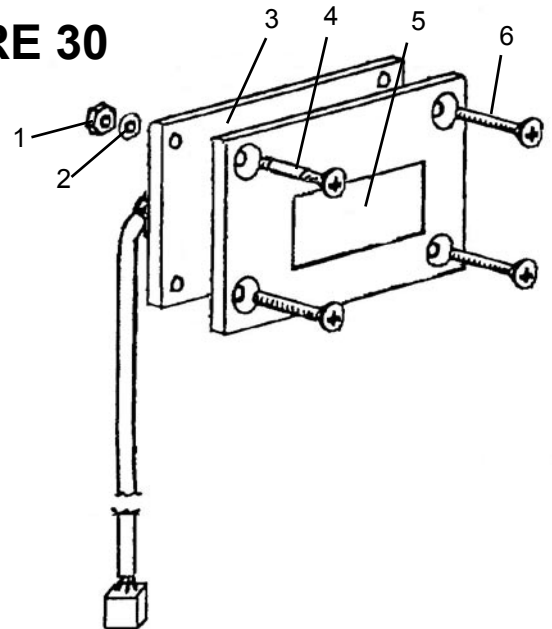

PARTS LIST FIGURE 30

Item No.	Part No.	Description
1	117-128	Nut (4)
2	120-048	Plastic Washer (4)
3	331-377	Display Board Assy (PSI)
	331-397	Display Board Assy (BAR)
4	117-281	Spacer (4)
5	331-360	Window
6	100-362	Screw (4)
-	331-304-99	LCD Kit (PSI)
-	331-305-99	LCD Kit (BAR)

Quick Flush™

- The only clean water flushing system
- Cuts sprayer clean-up time in half!
- Connects to standard garden hose to backflush sprayer through gun
- Includes "F" and "G" adapters to work with all brands of gun

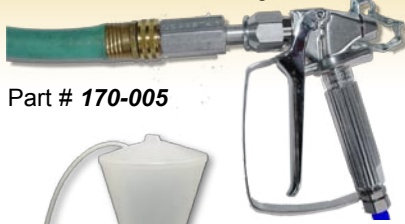

Part # **170-005**



PAINT HOPPER

For use on small jobs where paint is kept in smaller than 5 gallon containers. Threads onto pick-up tube of carry or LoBoy framed Airlessco sprayers.

331-775 6 Liter Paint Hopper



PUMP CONDITIONER

Should be used on piston pumps between uses to prevent paint from drying on the piston & causing packing wear.

010-001 Display of 48 - 1 oz. bottles
010-009 1 quart bottle
010-019 1 Gallon bottle

Case quantity: 12 on quarts, 4 on gallons



PAINT STRAINERS

Pre-filter your paint using strainer bags. One dozen per pack.

100-064 Used to cover suction filter
100-065 5 Gallon strainer



HOSE COVER

4 mil poly protects your airless hose from paint and abrasion damage. Comes in 1000' roll with perforations every 50'.

100-219 Hose Cover Roll
100-426 Case of 6 Rolls



HIGH PRESSURE AIRLESS HOSE

Strong yet flexible, for airless sprayers up to 3300 PSI

Part No:	Hose Description
100-012	3/16" Whip Hose, 4 Ft.
100-040	1/4" Whip Hose, 3 Ft.
100-204	1/4" Whip Hose, 5 Ft.
100-199	3/8" Whip Hose, 6 Ft.
100-011	1/4" Hose, 50 Ft.
100-023	3/8" Hose, 50 Ft.
100-037	1/2" Hose, 50 Ft.
100-010	1/4" Hose Connector
100-009	3/8" Hose Connector



STAY CLEAN™

Spray protectant for machine to prevent paint from sticking to it. Keeps your sprayer looking new for years!

114-030 20 oz. can
 Case quantity: 12 cans



THROAT SEAL OIL

Used in the wet cup of a piston pump to prevent paint from drying on the piston & causing damage to the upper packing. Use with all piston pumps.

188-187 6 oz. Bottle
188-392 1 qt. Bottle



XTEND-A-POLE SYSTEM

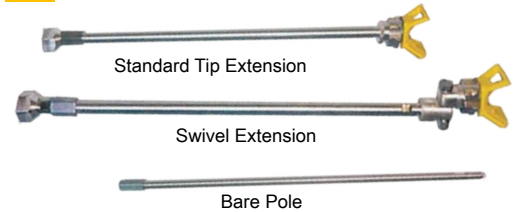

STANDARD TIP EXTENSION, "G" Thread

032-170 6" Long
032-171 12" Long
032-172 18" Long
032-173 24" Long

SWIVEL EXTENSION, "G" Thread

032-184 36" Long

BARE POLE

Add Tip Extension or Swivel Extension to create desired length

032-053 24" Long
032-054 36" Long

SWIVEL "G" THREAD

032-035-55 7/8" x 14 Swivel



ADAPTERS



90° Pole to Gun Adapter
032-042



Gun Nut "F" Thread 11/16-16
032-010



Gun Nut "G" Thread 7/8-14
032-011



"F to G" Gun adapter to attach Graco® tips to Airlessco guns.
032-012