



AIRLESS PAINT LINE STRIPER SERVICE/OPERATION MANUAL



**SURE STRIPE
3650 & 4050
FIELD STRIPE
MODEL D & PLUS**

TABLE OF CONTENTS

SECTION	FIGURE
Introduction.....	1 Filling the Packing Nut/Wet Cup.....
Safety Warnings	2 Spray Tip
Setting Up.....	3 Prime Valve
Flushing	4 Pressure Control Knob
How to Flush	5 Choke, Fuel Throttle
Starting Up	6 Static Discharge
Pressure Relief Procedure	7 Gun Safety Latch.....
Daily Maintenance	8 Major Gun Components
Line Striping Operation.....	9 Spray Tip
Airless Spray Gun Operation.....	10 Spray Tip Assembly.....
Airless Spray gun Assembly	11 Airless Spray Gun Assembly.....
Airless Spray Gun Troubleshooting.....	12 Fluid Pump
Rev Tips	13 Outlet Valve
Field Troubleshooting	14 Inlet Valve
Servicing Fluid Pump	15 Packing.....
Servicing Outlet Valve	16 Packing Cutaway.....
Servicing Inlet Valve	17 Gearbox Assembly
Packing Replacement Procedures	18 Clutch Assy.....
Gearbox Assembly	19 Frame Assembly.....
Clutch Assembly	20 Swivel Wheel Assembly
Frame Assembly.....	21 Gun Assembly
Swivel Wheel Assembly	22 Gun Holder Assembly.....
Gun Assembly	23 Paint System
Gun Holder Assembly.....	24 Suction Assembly
Paint System	25 Floating Gun Assembly
Suction Assembly	26 Control Board
Floating Gun Assembly	
Replacement of Electrical Control Board	
Pressure Calibration on the Control Board....	
Clutch Troubleshooting.....	
Notes	
Striping Accessories	
Airlessco Accessories.....	



INTRODUCTION



The Sure Stripe 3650 and Sure Stripe 4050, as well as their respective Field Stripe versions, the Field Stripe Model D and Field Stripe Plus (+) have been designed to produce professional results at very reasonable prices. Using our proven LP airless piston-powered paint pump, with triple life externally adjustable packing system and quality, clutch based, electronic pressure control system, the Sure Strip and Field Stripe stripers can be relied upon to get the job done for years to come.

Field Stripe units are equipped with a wheeled gun arm to ensure consistent lines on athletic fields.

All four units can also be used as mobile airless paint sprayers.



	SS3650	SS4050	FS Model D	FS Plus
Part No.	305-401	305-402	305-405	305-406
Max Pressure	3000 PSI	3000 PSI	3000 PSI	3000 PSI
Output (At Pressure)	0.70 GPM	0.80 GPM	0.70 GPM	0.80 GPM
Tip Size 1 Gun	0.027 in.	0.029 in.	0.027 in.	0.029 in.
Motor	Duro 4HP	Honda GX160	Duro 4hp	Honda GX160
Weight	166 lbs	166 lbs	171lbs	171 lbs

WARNING

**HANDLE THIS UNIT AS YOU WOULD A LOADED FIREARM!
HIGH PRESSURE SPRAY CAN CAUSE EXTREMELY
SERIOUS INJURY. OBSERVE ALL WARNINGS!**

MANUAL NOTATIONS

WARNING - Alerts user to avoid or correct conditions that could cause bodily injury.

CAUTION - Alerts user to avoid or correct conditions that could cause damage to or destruction of equipment.

IMPORTANT - Alerts users to steps or procedures that are essential to proper equipment repair and maintenance.

NOTE - Identifies essential procedures or extra information.

BEFORE OPERATING THIS UNIT, READ AND FOLLOW ALL SAFETY WARNINGS AND INSTRUCTIONS RELATED TO THE USAGE OF THIS EQUIPMENT ON PAGES 2, 3 & 4. READ, LEARN, AND FOLLOW THE PRESSURE RELIEF PROCEDURE ON PAGE 8 OF THIS MANUAL.

All Service Procedures to be performed by an Authorized Airlessco Service Center **ONLY**.
NO MODIFICATIONS or alterations of any **AIRLESSCO** Equipment or part is allowed.

WARNINGS

MEDICAL ALERT - Airless Spray Wounds

If any fluid appears to penetrate your skin, get **EMERGENCY MEDICAL CARE AT ONCE. DO NOT TREAT AS A SIMPLE CUT.** Tell the doctor exactly what fluid was injected. Have him read the following "NOTE TO PHYSICIAN".

NOTE TO PHYSICIAN: Injection in the skin is a traumatic injury. It is important to treat the injury surgically as soon as possible. **DO NOT DELAY** treatment to research toxicity. Toxicity is a concern with some exotic coatings injected directly into the blood stream. Consultation with a plastic surgeon or reconstructive hand surgeon may be advisable.

WARNING

HIGH PRESSURE SPRAY CAN CAUSE EXTREMELY SERIOUS INJURY. OBSERVE ALL WARNINGS. THIS SPRAYER IS FOR PROFESSIONAL USE ONLY.

INJECTION HAZARD

FLUIDS UNDER HIGH PRESSURE FROM SPRAY OR LEAKS CAN PENETRATE THE SKIN AND CAUSE EXTREMELY SERIOUS INJURY, INCLUDING THE NEED FOR AMPUTATION.

NEVER point the spray gun towards anyone or at any part of the body.

NEVER put hand or fingers over the spray tip. Do not use rag or other materials over your fingers. Paint will penetrate through material and into the hand.

NEVER try to stop or deflect leaks with your hand or body.

ALWAYS have gun tip guard in place when spraying.

ALWAYS lock gun trigger when you stop spraying.

ALWAYS remove tip from the gun to clean it.

NEVER try to "blow back" paint, it's not an air sprayer.

ALWAYS follow the **PRESSURE RELIEF PROCEDURE**, as shown on page 8, before cleaning or removing the spray tip or servicing any system equipment.

Be sure equipment safety devices are operating properly before each use.

ALWAYS tighten all fluid connections before each use.

MEDICAL TREATMENT

If any fluid appears to penetrate your skin, get **EMERGENCY CARE AT ONCE.**

DO NOT TREAT AS A SIMPLE CUT.

- Go to an emergency room immediately.
- Tell the doctor you suspect an injection injury.
- Tell him what kind of material you were spraying with and have him read **NOTE TO PHYSICIAN** above.

GENERAL PRECAUTION

NEVER alter equipment in any manner.

NEVER smoke while in spraying area.

NEVER spray highly flammable materials.

NEVER use around children.

NEVER allow another person to use sprayer unless he is thoroughly instructed on its' safe use and given this operators manual to read.

ALWAYS wear a spray mask, gloves and protective eye wear while spraying.

ALWAYS ensure fire extinguishing equipment is readily available and properly maintained.

NEVER LEAVE SPRAYER UNATTENDED WITH PRESSURE IN THE SYSTEM. FOLLOW PRESSURE RELIEF PROCEDURES ON PAGE 8.

ALWAYS INSPECT SPRAYING AREA

Keep spraying area free from obstructions.

Make sure area has good ventilation to safely remove vapors. **NEVER** keep flammable material in spraying area. **NEVER** spray in vicinity of open flame or other sources of ignition. Spraying area must be at least 20 ft. away from spray unit.

SPRAY GUN SAFETY

ALWAYS set safety lock on the gun in "**LOCKED**" position when not in use and before servicing or cleaning.

DO NOT remove or modify any part of gun.

ALWAYS remove spray tip when cleaning.

Flush unit with **LOWEST POSSIBLE PRESSURE.**

CHECK operation of all gun safety devices before each use. Be very careful when removing the spray tip or hose from gun. A plugged line contains fluid under pressure. If the tip or line is plugged, follow the **PRESSURE RELIEF PROCEDURE** as outlined on page 8.

TIP GUARD

ALWAYS have the tip guard in place on the spray gun while spraying. The tip guard alerts you to the injection hazard and helps prevent accidentally placing your fingers or any part of your body close to the spray tip.

SPRAY TIP SAFETY

USE EXTREME CAUTION when cleaning or changing spray tips. If the spray tip clogs while spraying, engage the gun safety latch immediately.

ALWAYS follow the **PRESSURE RELIEF PROCEDURE** before removing the spray tip to clean it.

NEVER wipe off build up around the spray tip.

ALWAYS remove tip & tip guard to clean **AFTER** pump is turned off and the pressure is relieved by following the **PRESSURE RELIEF PROCEDURE.**

WARNINGS CONTINUED ON NEXT PAGE.....

WARNINGS - CONTINUED

ALWAYS INSPECT SPRAYING AREA

Keep clear of moving parts when starting or operating the sprayer. Do not put your fingers into any openings to avoid amputation by moving parts or burns on hot parts. Precaution is the best insurance against an accident.

When starting the engine, maintain a safe distance from moving parts of the equipment.

Before adjusting or servicing any mechanical part of the sprayer, follow the **PRESSURE RELIEF PROCEDURE** on page 8, and remove the ignition cable from the spark plug to prevent accidental starting of sprayer.

HOSES

Tighten all fluid connections securely before each use. High pressure fluid can dislodge a loose coupling or allow high pressure spray to be emitted from the coupling and result in an injection injury or serious bodily injury.

Use only hose that has a spring guard. The spring guard helps protect the hose from kinks or other damage which could result in hose rupture and cause an injection injury.

NEVER use a damaged hose, which can result in hose failure or rupture and cause in injection injury or other serious bodily injury or bodily damage. Before each use, check entire hose for cuts, leaks, abrasion or bulging of cover, or damage or movement of couplings. If any of these conditions exist, replace the hose immediately. Never use tape or any device to try to mend the hose as it cannot contain the high pressure fluid. **NEVER ATTEMPT TO RECOUPLE THE HOSE.** High pressure hose is not recoupleable.

Help prevent damage to the hose by handling and routing it carefully. Do not move the sprayer by pulling it with the hose.

LABELING

Keep all labels on the unit clean and readable. Replacement labels are available from manufacturer.

TOXIC FLUID HAZARD

Hazardous fluid or toxic fumes can cause serious injury or death if splashed in eyes or on skin, inhaled or swallowed. Know the hazards of the fluid you are using. Store & dispose of hazardous fluids according to manufacturer, local, state & national guidelines.

ALWAYS wear protective eyewear, gloves, clothing and respirator as recommended by fluid manufacturer.

GROUNDING

Ground the sprayer and other components in the system to reduce the risk of static sparking, fire or explosion which can result in serious bodily injury and property damage.

ALWAYS GROUND ALL OF THESE COMPONENTS:

1. Sprayer: Connect a ground wire and clamp (supplied) to a true earth ground.
2. Fluid Hose: use only grounded hoses.
3. Spray gun or dispensing valve: grounding is obtained through connection to a properly grounded fluid hose and pump.
4. Object being sprayed: according to your local code.
5. All solvent pails used when flushing should only be metal pails which are conductive.

Once each week, check electrical resistance of hose (when using multiple hose assemblies, check overall resistance of unpressurized hose must not exceed 29 megohms (max) for any coupled length or combination of hose lengths. If hose exceeds these limits, replace it immediately.

Never exceed 500 Ft. (150 m.) overall combined hose length to assure electrical continuity.

WARNINGS CONTINUED ON NEXT PAGE.....

WARNINGS - CONTINUED

AVOID COMPONENT RUPTURE

This sprayer operates at 3000 psi (205 bar). **ALWAYS** be sure that all components and accessories have a maximum working pressure of at least 3000 psi to avoid rupture which can result in serious bodily injury including injection and property damage.

NEVER leave a pressurized sprayer unattended to avoid accidental operation of it which could result in serious bodily injury.

ALWAYS follow the **PRESSURE RELIEF PROCEDURE** whenever you stop spraying and before adjusting, removing or repairing any part of the sprayer.

NEVER alter or modify any part of the equipment to avoid possible component rupture which could result in serious bodily injury and property damage.

NEVER use weak or damaged or non-conductive paint hose. Do not allow kinking or crushing of hoses or allow it to vibrate against rough or sharp or hot surfaces. Before each use, check hoses for damage and wear and ensure all fluid connections are secure.

REPLACE any damaged hose. **NEVER** use tape or any device to mend the hose.

NEVER attempt to stop any leakage in the line or fittings with your hand or any part of the body. Turn off the unit and release pressure by following **PRESSURE RELIEF PROCEDURE**.

ALWAYS use approved high pressure fittings and replacement parts.

ALWAYS ensure fire extinguishing equipment is readily available and properly maintained.

WARNING

Do not use halogenated solvents in this system. The prime valve, 2 gun manifold and most airless guns have aluminum parts and may explode. Cleaning agents, coatings, paints or adhesives may contain halogenated hydrocarbon solvents. **DON'T TAKE CHANCES!** Consult your material suppliers to be sure. Some of the most common of these solvents are: Carbontetrachloride, Chlorobenzene, Dichloroethane, Dichloroethyl Ether, Ethylbromide, Ethylchloride, Tetrachloroethane. Alternate valves and guns are available if you need to use these solvents.

PREVENT STATIC SPARKED FIRE/ EXPLOSIONS

ALWAYS be sure all equipment and objects being sprayed are properly grounded. **ALWAYS** ground sprayer, paint bucket and object being sprayed. See "grounding" on page 3 for detailed grounding information.

Vapors created when spraying can be ignited by sparks. To reduce the risk of fire, always locate the sprayer at least 20 feet (6 m.) away from the spray area. **DO NOT** plug in or unplug any electrical cords in the spray area, which can create sparks, when there is any chance of igniting vapors still in the air. Follow the coating & solvent manufacturers safety warnings and precautions.

Use only conductive fluid hoses for airless applications. Be sure gun is grounded through hose connections. Check ground continuity in hose & equipment. Overall (end to end) resistance of unpressurized hose must not exceed 29 megohms for any coupled length or combination of hose length. Use only high pressure airless hoses with static wire approved for 3000 psi.

FLUSHING

Reduce the risk of injection injury, static sparking or splashing by following the specific cleaning procedure on page 6 and 8.

ALWAYS follow the **PRESSURE RELIEF PROCEDURE** on page 8.

ALWAYS remove the spray tip before flushing. Hold a metal part of the gun firmly to the side of a metal pail and use the lowest possible fluid pressure during flushing.

NEVER use cleaning solvents with flash points below 140 degrees F. Some of these are: acetone, benzene, ether, gasoline, naphtha. Consult your supplier to be sure.

NEVER SMOKE IN THE SPRAYING/CLEANING AREA.

GAS ENGINE PRECAUTIONS

Place unit 25 feet away from spraying in ventilated area.

NEVER operate in buildings unless exhaust is piped outside.

NEVER allow hose to lay against engine mufflers or hot parts.

NEVER refill fuel tank while engine is hot or is running.

IMPORTANT: United States Government safety standards have been adopted under the Occupational Safety & Health Act. These standards, particularly the General Standards, Part 1910, & the Construction Standards, part 1926 should be consulted.

WHEN SPRAYING & CLEANING WITH FLAMMABLE PAINTS OR THINNERS:

1. When spraying with flammable liquids, the unit must be located a minimum of 25 feet away from the spraying area in a well ventilated area. Ventilation must be sufficient enough to prevent the accumulation of vapors.
2. To eliminate electrostatic discharge, ground the spray unit, paint bucket and spraying object. Use only high pressure airless hoses approved for 3000 psi which is conductive.
3. Remove spray tip before cleaning gun and hose. Make contact of gun with bucket and spray without the tip in a well ventilated area, into the grounded steel bucket.
4. Never use high pressure in the cleaning process. **USE MINIMUM PRESSURE.**
5. Do not smoke in spraying/cleaning area.

SETTING UP

1. CONNECT THE HOSE AND GUN

- Remove the plastic cap plug from the outlet and screw a conductive or grounded 3000 psi spray hose onto fluid outlet.
- Connect an airless spray gun to the other end of the hose, but do not install the spray tip yet!

NOTE: Do not use thread sealer on swivel unions as they are made to self seal.

NOTE: The 6' whip hose should always be 3/8".

2. FILL THE PACKING NUT/WET CUP

Fill the Packing Nut/Wet Cup 1/3 full with Airlessco Throat Seal Oil (TSO). **FIG 1 BELOW.**

FIG. 1

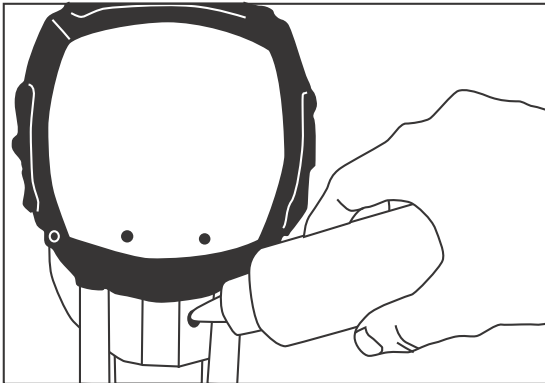

3. CHECK THE ENGINE OIL LEVEL

- Unscrew the oil fill plug. The dipstick is attached to the plug.
- Without threading the plug into place, check to be sure the oil is up to the top mark on the dipstick.
- If oil is needed, refer to engine manual.

4. FILL THE FUEL TANK

WARNING: Fuel spilled on a hot surface can cause a fire or explosion and cause serious bodily injury and property damage. Always shut off the engine and let it cool before filling the tank, and carefully follow steps a - c below being sure not to spill any fuel.

- Close the fuel shutoff valve.
- Use only clean, fresh, well-known brands of unleaded regular grade gasoline.
- Remove the fuel cap and fill tank. Be sure the air vent in the fill cap is not plugged so fuel can flow to the carburetor, then replace the cap.

5. FLUSH THE SPRAYER

- Flush sprayer per instructions below.

FLUSHING

1. NEW SPRAYER

Your unit was factory tested in an anti-freeze solution which was left in the pump. Before using oil-base paint, flush with mineral spirits only.

Before using water-base paint flush with mineral spirits, followed by soapy water, then a clean water flush.

2. CHANGING COLORS

Flush with a compatible solvent such as mineral spirits or water.

3. CHANGING FROM WATER-BASE TO OIL-BASE PAINT

Flush with soapy water, then mineral spirits.

4. CHANGING FROM OIL-BASE TO WATER-BASE PAINT

Flush with mineral spirits, followed by soapy water, then a clean water flush.

5. STORAGE

Oil-base paint: Flush with mineral spirits.

Water-base paint: Flush with water, then mineral spirits and leave the pump, hose and gun filled with mineral spirits.

For longer storage, use mixture of mineral spirits and motor oil (half & half). Shut off the sprayer, follow **PRESSURE RELIEF PROCEDURE** on page 8 to relieve pressure and make sure prime valve is left open.

6. START UP AFTER STORAGE

Before using water-base paint, flush with soapy water and then a clean water flush.

When using oil-base paint, flush out the mineral spirits with the material to be sprayed.

HOW TO FLUSH

1. Be sure the gun safety latch is engaged and there is no spray tip in the gun. Refer to Fig. 2. Refer to your separate instruction manual provided with your gun on its safety features and how to engage safety latch.
2. Pour enough clean, compatible solvent into a large, empty metal pail to fill the pump and hoses.
3. Place the suction tube into the pail or place the pail under the pump.
4. Turn pressure control knob to low. Refer to Fig. 4.
5. Open the prime valve to the open - "Priming Position". This will allow an easy start. Refer to Fig. 3.
6. Turn the engine ON/OFF switch to ON.
7. Move the choke toward the closed position as per Fig.5.
8. Move the throttle lever slightly to the left as per Fig.5.
9. Turn the fuel valve ON as per Fig. 5. Pull the start rope. Pull the engine over against compression stroke and then let the rope rewind slowly into the starter. Pull firmly and rapidly to start the engine. Do NOT drop the rope. Hold on to the handle while rewinding, or the rope may rewind improperly and jam the assembly. If the engine does not start, open the choke a little more. If the engine floods, open the choke all the way and continue cranking.
10. After the engine is warm, gradually close the choke, raise the RPM of engine slightly by moving throttle to the left. Close the prime valve. Refer to Fig. 3
11. Point the gun into the metal pail and hold a metal part of the gun firmly against the pail Refer to fig. 6.
12. Disengage the gun safety latch and squeeze the gun trigger. At the same time, slowly turn the pressure control knob clockwise just enough to move liquid at low pressure.
13. Allow the pump to operate until clean solvent comes from the gun.
14. Release the trigger and engage the gun safety latch.
15. If you are going to start spraying, place the pump or suction tube into the supply container. Release the gun safety latch and trigger the gun into another empty, metal container, holding a metal part of the gun firmly against the metal pail (Fig. 6), forcing the solvent from the pump and hose. When paint starts coming from gun, turn pressure control knob to minimum pressure, place prime valve in prime (open) position and engage the gun safety latch.
16. If you are going to store the sprayer, remove the suction tube or pump from the solvent pail force the solvent from the pump and hose. Engage the gun safety latch and refer to the "Storage" Procedure on page 5. Step 5.
17. Whenever you shut off the sprayer follow the **PRESSURE RELIEF PROCEDURE** warning on page 8.

FIG. 2



FIG. 3

PRIME VALVE

CLOSED
(Pressure)

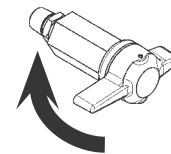

OPEN
(Priming &
Pressure Relief)

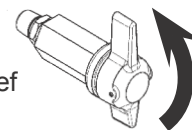

FIG. 4

PRESSURE CONTROL KNOB



FIG. 5

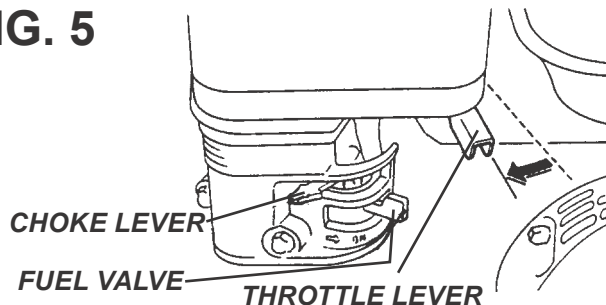

FIG. 6

MAINTAIN FIRM METAL TO METAL CONTACT BETWEEN GUN AND CONTAINER



WARNING: To reduce the risk of static sparking, which can cause fire or explosion, always hold a metal part of the gun firmly against the metal pail when flushing. This also reduces splashing. Refer to Fig 6.

STARTING UP

1. LEARN THE FUNCTIONS OF THE CONTROLS.

PRIME/PRESSURE (PR) RELIEF VALVE is used to prime pump and to relieve pressure from gun, hose and tip.

(Prime/PR Valve) Used to relieve pressure from gun, hose & tip and to prime the unit when in **OPEN** position. (It is in open position when there is a wider gap between valve handle and cam body.)

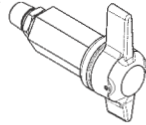

When in **CLOSED** position, there is only a very slight gap between handle & body. When closed the system is pressurized. Handle as a loaded firearm!

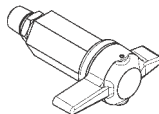

PRESSURE CONTROL KNOB is used to adjust pressure. Turn clockwise (CW) to increase pressure and counterclockwise (CCW) to decrease pressure.

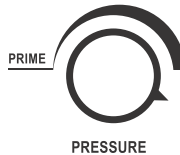

2. PREPARE THE MATERIAL

- Prepare the material according to the material manufacturer's recommendations.
- Place the suction tube into the material container.

3. STARTING THE SPRAYER

- Prime/PR Valve must be "OPEN" in the priming position.
- When you have ensured that the gun safety latch is engaged, attach tip and safety guard.
- Turn the engine ON/OFF switch to the "ON" position. Pull rope vigorously until engine starts.
- Turn Pressure Control Knob clockwise to prime the pump.
- After the pump is primed, turn Prime/PR Valve to the "Closed" position.
- Turn Pressure Control Knob to the desired spray pressure.
- Disengage the gun safety latch and you are ready to spray.

4. ADJUSTING THE PRESSURE

- Turn the Pressure Control Knob Clockwise to increase pressure and counterclockwise to decrease pressure.
- Always use the lowest pressure necessary to completely atomize the material.

NOTE: OPERATING THE SPRAYER AT HIGHER PRESSURE THAN NEEDED, WASTES MATERIAL, CAUSES EARLY TIP WEAR, AND SHORTENS SPRAYER LIFE.

- If more coverage is needed, use a larger tip rather than increasing the pressure.
- Check the spray pattern. The tip size and angle determines the pattern width and flow rate.

WARNING

FOLLOW THE "PRESSURE RELIEF PROCEDURE".

To reduce the risk of injection, never hold your hand, body, fingers or hand in a rag in front of the spray tip when cleaning or checking for a cleared tip. Always point the gun toward the ground or into a waste container when checking to see if the tip is cleared or when using a self-cleaning tip.

WARNING

When you spray into the paint bucket, always use the lowest spray pressure and maintain firm metal to metal contact between gun and container.

WARNING

To stop the unit in an emergency, turn the engine off. Then relieve the fluid pressure in the pump and hose as instructed in the Pressure Relief Procedure.

5. WHEN SHUTTING OFF THE SPRAYER

- Whenever you stop spraying, even for a short break, follow the "Pressure Relief Procedure".
- Clean the tip & gun as recommended in the separate Gun Manual supplied with the gun.
- Flush the sprayer at the end of each work day, if the material you are spraying is water-based, or if it could harden in the sprayer overnight. See "Flushing". Use a compatible solvent to flush, then fill the pump and hoses with an oil based solvent such as mineral spirits.
- For long term shutdown or storage, refer to the "Flushing" section of this manual.

WARNING

Be sure to relieve pressure in the pump after filling with Airlessco Pump Conditioner.

AVOIDING TIP CLOGS

There is an easy way to keep the outside of the tip clean from material build up:

Every time you stop spraying, for even a minute, lock the gun and submerge it into a small bucket of thinner suitable for the material sprayed.

Thinner will dissolve the buildup of paint on the outside of tip, tip guard and gun much more effectively if the paint doesn't have time to dry out completely.

PRESSURE RELIEF PROCEDURE



IMPORTANT!

TO AVOID POSSIBLE SERIOUS BODY INJURY, ALWAYS FOLLOW THIS PROCEDURE WHENEVER THE SPRAYER IS SHUT OFF, WHEN CHECKING IT, WHEN INSTALLING, CHANGING OR CLEANING TIPS, WHENEVER YOU STOP SPRAYING, OR WHEN YOU ARE INSTRUCTED TO RELIEVE THE PRESSURE.

1. Engage the gun safety latch. Refer to the separate instruction manual provided with your gun on its safety features and how to engage safety latch.
2. Turn the unit off.
3. Disengage the gun safety latch and trigger the gun to relieve residual fluid pressure.

HOLD METAL PART OF THE GUN IN CONTACT WITH GROUNDED METAL PAIL. USE MINIMUM PRESSURE !

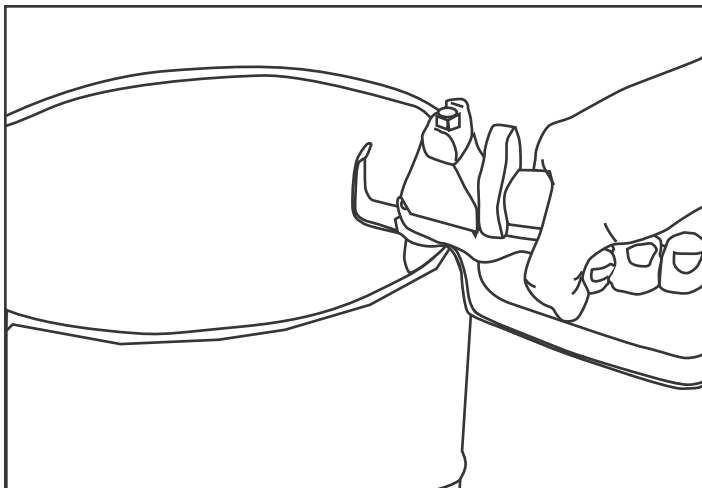

4. Turn Prime/Pressure Relief Valve (PR Valve) to the open (priming) position to relieve residual fluid pressure.

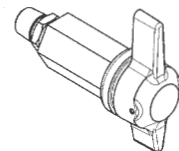

THERE WILL BE A WIDER GAP BETWEEN VALVE HANDLE AND CAM BODY WHEN IN OPEN POSITION. IN THE CLOSED POSITION THERE IS ONLY A VERY SLIGHT GAP.

NOTE: THE VALVE HANDLE CAN MOVE BOTH CLOCKWISE AND COUNTER CLOCKWISE AND CAN FACE DIFFERENT DIRECTIONS.

5. Re-engage gun safety latch and close Prime/Pressure Relief Valve.

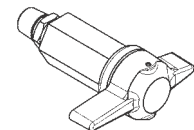

If the **SPRAY TIP OR HOSE IS CLOGGED**, follow Step 1 through 5 above. Expect paint splashing into the bucket while relieving pressure during Step 4.

If you suspect that pressure hasn't been relieved due to damaged Prime/Pressure Relief Valve or other reason, engage the gun safety latch and take your unit to an authorized Airlessco Service Center.

DAILY MAINTENANCE

1. Always stop the pump at the bottom of its stroke when you take a break or at the end of the day. This helps keep material from drying on the rod, damaging the packings.
2. Keep the displacement pump packing nut/wet cup 1/3 full of Airlessco Throat Seal Oil at all times. The TSO helps protect the packings and rod.
3. Lubricate Connecting Rod Pin every 3 months.
4. Inspect the packing nut daily. Your paint pump has Airlessco's patented "Triple Life Packing System". Packing life will be extended a minimum of 3 times if the proper packing tightening procedure is followed!

PACKING TIGHTENING PROCEDURE:

Inspect the packing nut daily! If seepage of paint into the packing nut and/ or movement of the piston upward is found (while not spraying), the packing nut should be tightened enough to stop leakage only, but not any tighter. **OVERTIGHTENING WILL DAMAGE THE PACKINGS** and reduce the packing life to the life of other piston pumps.

LINE STRIPING OPERATION

1. CHOOSE THE GUN ARM POSITION

There is a hole in each corner of the striper frame, in which the gun arm can be mounted. In a standard set up, the gun arm would be mounted in the right hand near the single wheel. This allows for an easier visual check for straight line striping and for basic arc striping.

2. CHOOSE THE HANDLEBAR POSITIONS

Choose the handlebar position. The handlebars can be adjusted by loosening the bolts (fig. 19, item 10) and rotating each handlebar to desired heights, then tightening the bolts. Rotating the handlebars all the way forward allows for easy storage of the unit.

3. SETTING UP THE GUNS

- Ensure that a striping tip is in the gun.
- Pick a tip size for the desired line width.
EXAMPLE: a 317ST tip for a four inch line.
- Place gun into the gun holder, so that the top of the taper on the gun handle is flush with the edge of the gun holder.
- Set gun height for the desired line width. Adjust height by loosening the small black handle on the gun holder assembly and slide the gun arm to the correct height. Now tighten the handle. This will require some experimentation to find the correct height. It is suggested that tape, or some other method is used to mark the height of commonly used settings.
- Attach the swivel heads to the gun if painting curbs or wide stripes.
- Angle the guns slightly forward. This allows the spray pressure from the guns to help blow dirt and debris out of the path of the new stripes.

4. CABLE TENSION ADJUSTMENT

Once the handle and gun arm assembly is set up to the preferred position, pressurize the unit and trigger the gun to ensure that it activates and releases correctly. If not, adjust the cable tension as follows:

- Locate the adjustment knobs on the base of the gun trigger, where the cable connects to the gun trigger assembly.
- Loose the locking nut and move the adjusting screw until the slack has been removed from the cable.
- Tighten locking nut and retest gun triggers for proper function.

NOTE: THERE IS AN ADDITIONAL CABLE ADJUSTMENT WHERE THE CABLE ATTACHES TO THE GUN HOLDER ASSEMBLY. USE ONLY IF THE GUN TRIGGER ADJUSTMENT IS INSUFFICIENT.

5. ALIGN SWIVEL WHEEL ASSEMBLY

STRAIGHT LINES

- Stripers are factory aligned, but if necessary, loosen the two bolts (fig. 20, item 19) on the swivel wheel assembly, just enough to be able to move the wheel by hand. Align wheel and re-tighten bolts.
- Place the turnbuckle over the two mounting nubs on the frame.
- Pressurize the unit with water and Airlessco's Pump Conditioner and spray out several lines with the swivel assembly in the locked position. Use the turnbuckle to fine tune the alignment of the wheels, until the stripes are straight.
- Tighten the jam nuts on the turnbuckle to affix the turnbuckle length for future reference.
- Tighten the ratchet handles.

CURVES AND ARCS

Basically the same as above, except the swivel wheel assembly is set at angle. The swivel assembly can be adjusted to 30 degrees either side of straight ahead. If you have arcs that you paint regularly, purchase additional turnbuckles (136-231) and keep them set to those arc sizes.

6. MISCELLANEOUS OPERATIONS

- CURBS:** Adjust gun to desired height and turn swivel head towards curb.
- WIDE STRIPES:** Install wider fan striping tips and raise the gun height to achieve the desired width line.
- STENCILS:** Install standard spray tip on the outer gun. Remove this gun from the gun holder and spray out the stencils. A second gun and hose can be attached and bolted with a ball valve for stencils.
- STANDARD PAINTING:** Same as stencils, but use additional paint hose as required.

AIRLESS SPRAY GUN OPERATION

SPRAY

Attach spray gun to airless unit and tighten fittings securely. Set the gun safety latch. (Also may be called gun safety lock, or trigger lock)

* The gun safety latch should always be set when the gun is not being triggered.

Read all warnings and safety precautions supplied with the spray gun and in product manual.

FIG. 7

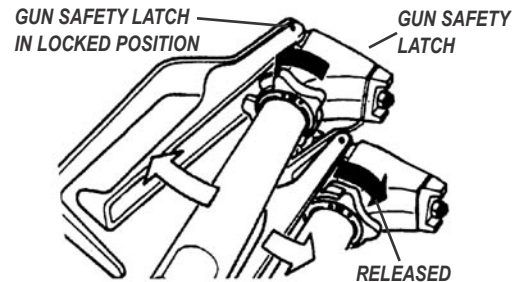

MAJOR COMPONENTS OF SPRAY GUN AND REVERSIBLE SPRAY TIP

FIG. 8

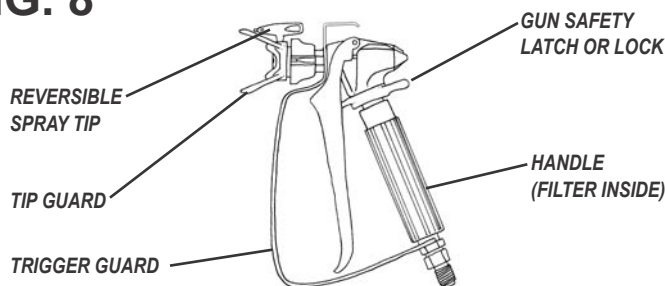
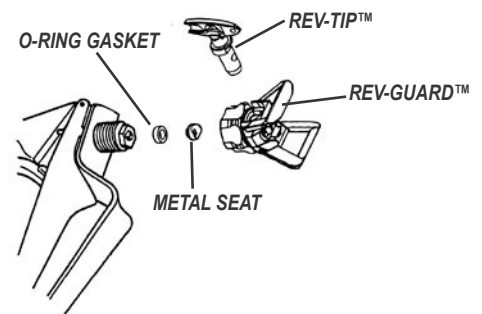

FIG. 9



SPRAY TIP ASSEMBLY

1. Be sure pressure relief procedure is followed before assembling tip and housing to the gun.
2. Lock gun safety latch.
3. Insert REV-TIP™ cylinder into the REV-GUARD™ (guard housing assembly).
4. Guide metal seat into REV-GUARD™ (guard housing assembly) through retaining nut & turn until it seats against the cylinder.
5. Insert O-Ring gasket on metal seat so it fits in the grooves.
6. Finger tighten REV-GUARD™ retaining nut onto the gun.
7. Turn guard in the desired position.
8. Completely tighten the retaining nut.

FIG. 10

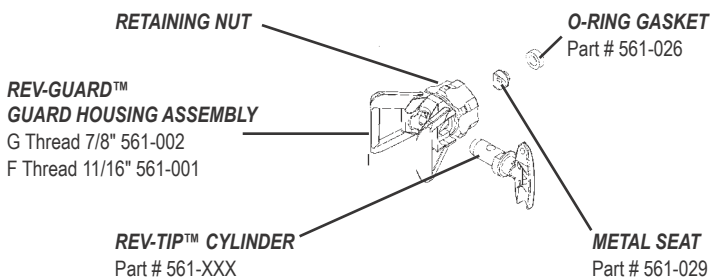

CLEANING SPRAY GUN

Immediately after the work is finished, flush the gun out with a solvent. Brush pins with solvent and oil them lightly so they will not collect dried paint.

CLEANING FILTER IN GUN HANDLE

To clean the filter, use a brush dipped in an appropriate solvent. Change or clean filters at least once a day. Some types of latex may require a filter change after four hours of operation.

TO REMOVE CLOGS FROM SPRAY TIP

1. Lock gun safety latch.
2. Turn REV-TIP™ handle 180 degrees.
3. Disengage trigger lock & trigger gun into pail.
4. If the REV-TIP™ handle appears locked (resists turning), loosen the retaining nut. The handle will now turn easily.
5. Engage gun safety latch & return handle to the spray position.

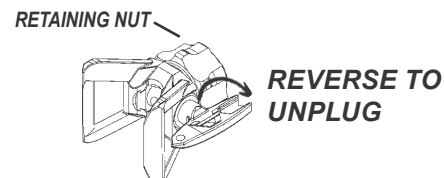

Spray Position Shown

CLOGGED FLAT TIP

Should the spray tip become clogged, relieve pressure from hose by following the "Pressure Relief Procedure." Secure gun with the safety latch, take off guard, take out the tip, soak in appropriate solvent & clean with a brush. (Do not use a needle or sharp pointed instrument to clean the tip. The tungsten carbide is brittle and can chip.)

AIRLESS SPRAY GUN

FIG. 11

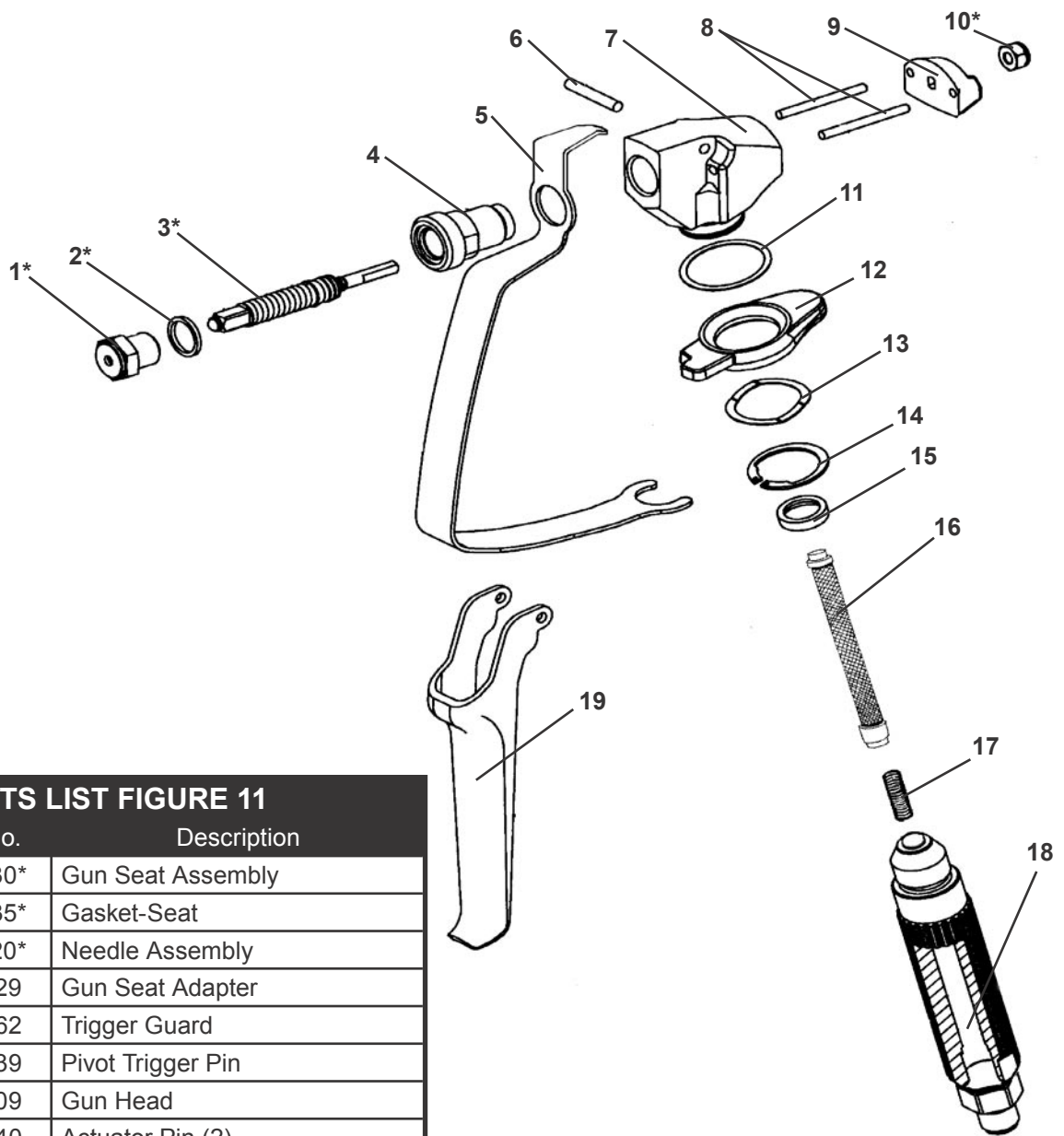

PARTS LIST FIGURE 11

Item No.	Part No.	Description
1	120-530*	Gun Seat Assembly
2	120-535*	Gasket-Seat
3	120-520*	Needle Assembly
4	120-529	Gun Seat Adapter
5	120-562	Trigger Guard
6	120-539	Pivot Trigger Pin
7	120-509	Gun Head
8	120-540	Actuator Pin (2)
9	120-536	Gun Plate
10	120-038*	Nut
11	120-056	Plastic Washer
12	120-538	Gun Trigger Lock
13	120-055	Wave Washer
14	120-049	Retaining Ring
15	120-082	Handle Seal
16	120-090CX	Gun Filter-Coarse
	120-090FX	Gun Filter-Fine
17	120-088	Spring
18	120-099	Gun Handle Assembly
19	120-506	Gun Trigger
*	120-534	Gun Repair Kit

AIRLESS SPRAY TROUBLESHOOTING

DEFECTS	CAUSE	CORRECTION
Coarse spray	Low pressure	Increase the pressure
Excessive fogging (overspray)	High pressure Material too thin	Reduce the pressure to satisfactory pattern distribution Use less thinner
Pattern too wide	Spray angle too large	Use smaller spray angle tip
Pattern too narrow	Spray angle too small	use larger spray angle tip (if coverage is OK, try tip in same nozzle group)
Too much material	Nozzle too large Material too thin Pressure too high	Use smaller nozzle Reduce pressure
Too little material	Nozzle too small	Use next larger nozzle Material too thick
thin distribution in center of pattern "horns"	Worn tip Wrong tip	Change to new tip Use nozzle with narrow spray angle
Thick skin of work	Material too viscous Application too heavy	Thin cautiously Reduce pressure and/or use tip in next smaller nozzle group
Coating fails to close & smooth over	Material too viscous	Thin cautiously
Spray pattern irregular, deflected	Orifice clogged Tip damaged	Clean carefully Replace with new tip
Craters or pock marks, bubbles on work	Solvent balance	Use 1 to 3% "short solvents remainder "long" solvents (this is most likely to happen with material of low viscosity, lacquers, etc.)
Clogged screens	Extraneous material in paint Course pigments Poorly milled pigments (paint pigments glocculate)	Clean screen Use coarse screen if orifice size allows. Use courser screen, larger orifice tips. Obtain ball milled paint. If thinner has been added, test to see if a cover screen. Incompatible drop placed on top of paint mixes or flattens out on the paint mixture & thinners on the surface. If not, try different thinner in fresh batch of paint.

TEST THE PATTERN

GOOD, FULL



SPOTTY PATTERN, INCREASE PRESSURE



LINE STRIPING TIP CHART

NOTE: STRIPING TIPS SHOULD NOT BE USED FOR REGULAR SPRAYING.

REV-TIP™ for Striping, Part Number 562-xxxST

TIP IDENTIFICATION

- 1st 3-digits identifies it as a **REV-TIP™** for airless line striping (Part Number 562-xxxST).
- 4th digit is the fan width - the number is half the fan width, e.g., 2 means a 4" line width.
- 5th and 6th digits are for the orifice size and is measured in thousandths of an inch, e.g., 17 = 0.017 inch.

The higher the number, the larger the tip.

REVERSIBLE STRIPING TIP SIZE CHART

REV-TIP™ FOR STRIPING 562-XXXST

FAN WIDTH (6" FROM SURFACE)		ORIFICE SIZE (INCHES)				
INCHES	MILLIMETERS	.013	.015	.017	.019	.021
1-2	25-51	113ST	115ST	117ST		
2-4	51-102		215ST	217ST	219ST	221ST
4-6	102-152		315ST	317ST	319ST	321ST
6-8	152-203		415ST	417ST	419ST	421ST
Striping paint		Oil Base	Oil Base	Latex	Latex	Latex

REV-TIP™ protected By U.S. Patent No. 6,264,115. Other U.S. & foreign patents applied for.

TIP REPLACEMENT

During use, high pressure will cause the orifice to grow larger. This destroys the pattern or will leave tailing or two heavy lines on the outside of the pattern. **REPLACE SPRAY TIP FREQUENTLY!**

FIELD TROUBLESHOOTING

PROBLEM	CAUSE	SOLUTION
Unit doesn't prime	Airleak due to: <ul style="list-style-type: none"> • Loose suction nut • Worn o-rings • Hole in suction hose Stuck or fouled balls	<ul style="list-style-type: none"> • tighten suction nut • replace o-ring (106-011) on suction seat & o-ring (106-020) below suction seat • replace suction hose (331-290) • service outlet valve suction assembly
Unit primes but has poor or no pressure	Pressure set too low Filter(s) are clogged Outlet valve fouled/worn Prime/pressure relief valve bypassing Packings and/or piston worn	<ul style="list-style-type: none"> • turn up pressure • clean or replace gun filter, inlet filter, and/or manifold filter • service outlet valve • clean or replace prime valve • tighten packing nut • repack unit
Unit does not maintain good spraying pressure	Blown spray tip Packings and/or pistons worn Upper seat worn	<ul style="list-style-type: none"> • replace spray tip • repack unit • replace upper seat

SERVICING THE FLUID PUMP

FLUID PUMP DISCONNECT

REFER TO FIGURE 12

1. Follow the Pressure Relief Procedure on page 8.
2. Flush the material you are spraying out of the machine.
3. Remove the connecting rod shield.
4. Move the piston rod to its lowest position by cycling pump slowly.
5. Turn off the motor.
6. Disconnect sensor by holding it in place with a 7/8" wrench and unscrewing the swivel with a 11/16" wrench.
7. Remove the retaining ring from the connecting rod and slide the sleeve down revealing the connecting rod pin.
8. Remove the suction tube assembly from the fluid pump by unscrewing the suction nut with the packing adjustment tool (189-211).
9. Using a 1/2" wrench unscrew the two bolts from the cover assembly. The fluid pump will be hanging loosely at this point.
10. Remove the connecting rod pin out of the connecting rod, allowing the removal of the fluid pump from the machine.

FLUID PUMP REINSTALL

REFER TO FIGURES 12 & 14

1. Loosen the packing nut and ensure that the piston rod is in its upper position in the fluid pump body. Slip the sleeve & the retaining ring over the piston rod.
2. Push the piston rod up into the connecting rod & align the holes. Insert the connecting rod pin through the connecting rod & piston. Slip the sleeve up over the connecting rod pin and insert the retaining ring into the groove on the connecting rod.
3. Push the two bolts through the tube spacers & screw them into the cover assembly. Using a 1/2" wrench, tighten the two bolts evenly (alternating between them) until you reach 20 ft-lbs.
4. Reassemble lower suction valve assembly by placing the suction seat, O-ring, suction ball & suction ball guide in the suction nut & screw onto fluid pump body.
5. Reconnect sensor to the fluid pump body. Hold sensor with a 7/8" wrench while tightening the swivel with a 11/16" wrench.
6. Start the machine and operate slowly to check the piston rod for binding. Adjust the two bolts, holding the fluid pump body to the cover assembly, if necessary. This will eliminate any binding.
7. Tighten packing nut clockwise until resistance is felt against the Belleville Springs, go 3/4 of a turn more. Put five drops of Airlessco Throat Seal Oil in the packing nut.
8. Run the machine at full pressure for several minutes. Release the pressure by following the Pressure Relief Procedure & readjust the packing nut per step 7 above.
9. Install the connecting rod shield so that the small hole is in the upper right hand corner.

FIG. 12

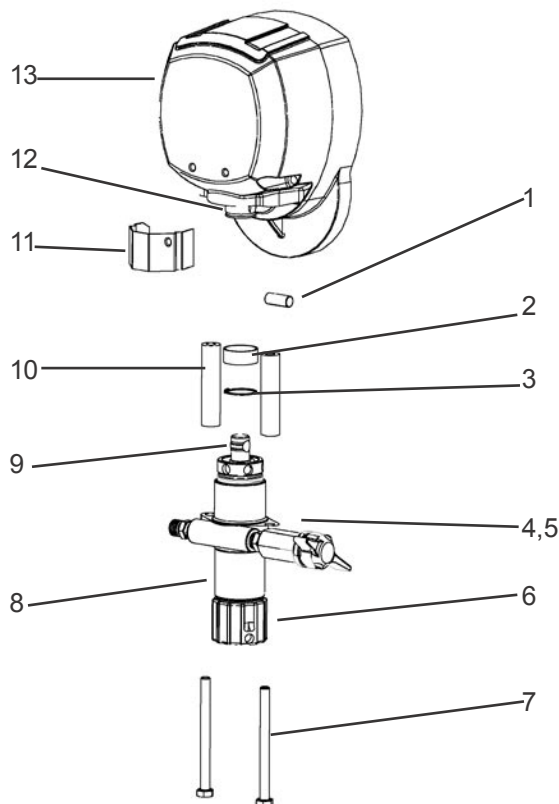

PARTS LIST FIGURE 12

Item No.	Part No.	Description
1	119-028	Connecting Rod Pin
2	331-117	Sleeve
3	331-062	Retaining Ring
4	115-019	Hose Connector
5	100-603	Swivel
6	331-034	Suction Nut
7	100-318	Bolts
8	331-209	Fluid Pump
9	331-093	Piston Rod
10	331-074	Tube Spacers
11	331-111	Connection Rod Shield
12	331-038	Connecting Rod
13	331-537	Cover Assembly

SERVICING THE OUTLET VALVE

DISASSEMBLY OF THE OUTLET VALVE

1. Disconnect the Fluid Pump following instructions on page 14.
2. Place piston holder in a vise. Slide piston into the holder & lock in place with a 3/8" dowel.
3. Use a 1/4" allen wrench to unscrew the outlet seat retainer from the piston.
4. Remove the outlet seat, O-ring and outlet ball.
5. Inspect outlet ball & seat for wear. Replace as necessary. Ensure seat is right side up.
6. While piston is still locked in the holder, install parts back into the piston in the following order:

BALL, OUTLET SEAT AND O-RING

Before reinstalling the outlet seat support, apply two drops of Loctite No. 242 (blue) on the threads & torque to 20 ft-lbs.

NOTE: Airlessco LP pump tool kit 188-197 is required for this task. Kit includes: Tightening Bar (189-211), Packing Removal Tool (331-465), Piston Holder (331-195), 3/8" dowel (331-196).

FIG. 13

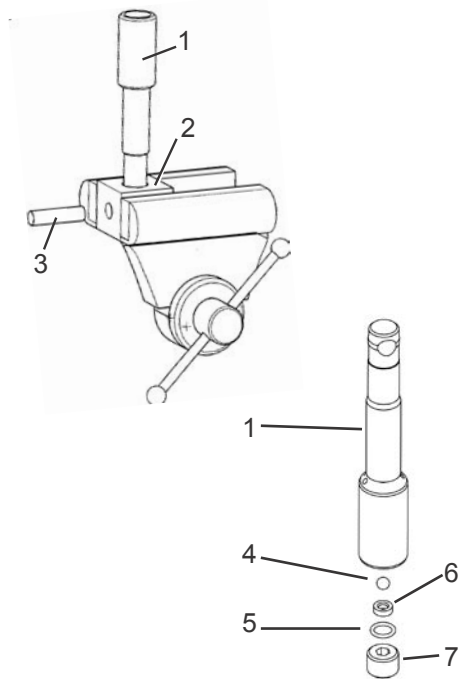

SERVICING THE INLET ASSEMBLY

1. Un-thread and remove suction nut from the fluid pump body.
2. Remove suction seat, O-ring, suction ball and suction retainer.
3. Clean all parts and inspect them for wear or damage, replacing parts as needed.
4. Clean inside of the fluid pump body.
5. Reassemble lower suction valve assembly by placing the suction seat, O-ring, suction ball & suction ball guide in the suction nut & screw onto fluid pump body.

FIG. 14

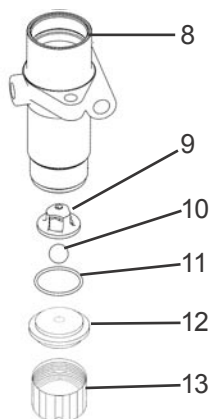

PARTS LIST FIGURE 13 & 14

Item No.	Part No.	Description
1	331-708	Piston
2	331-195	Piston Holder
3	331-196	Dowel Pin
4	331-027	Outlet Ball
5	331-100	O-Ring
6	331-026	Outlet Seat
7	331-314	Outlet Seat Retainer
8	331-011	Fluid Pump Body
9	331-029	Suction Ball Guide
10	331-030	Suction Ball
11	106-011	O-Ring
12	331-409	Suction Seat
13	331-034	Suction Nut

PACKING REPLACEMENT PROCEDURES











DISASSEMBLY OF THE FLUID PUMP

REFER TO FIGURE 15 & 16

1. Disconnect the Fluid Pump as instructed on page 14.
2. Unscrew & remove the packing nut.
3. Push the piston rod down through the packings & out of the pump.
4. Now push the packing removal tool up through the pump & remove from the top bringing packings, spacer & springs along with it, leaving fluid body empty.
*Make sure all old packings & glands have been removed from fluid pump.
5. Clean inside of fluid body.
6. Disassemble all parts & clean for reassembly. Discard any old packings.
7. Lubricate leather packing in lightweight oil for 10 minutes prior to reassembly.

REASSEMBLY

REFER TO FIGURE 15

1. Take lower male gland & place it down on the flat side. 
2. Take three of the lower polyethylene packings & two of the leather packings & place onto the male gland in the following order with the inverted side down 
POLYETHYLENE, LEATHER, POLYETHYLENE, LEATHER, POLYETHYLENE.
3. Take the female adaptor, which is inverted on both sides , & place it on top of your assembled lower packings.
4. Follow step 2 with your packings inverted side up. 
5. Take the second lower male gland and place it on top of your assembled packings with the rounded side down. 
6. Take assembled glands & packings (13 pieces) & slide onto the lower half of the piston.
7. Take the spacer & slide over the top of the piston (it doesn't matter which direction it sits, falling onto lower packings).
8. Take three Belleville Springs & slide over the top of the piston in the following order:
 - First spring, curve facing down 
 - Second spring, curve facing up 
 - Third spring, curve facing down 
9. Take the upper male gland & place it rounded side up. 
10. Take three upper polyethylene packings & two leather packings & assemble with inverted side down,  on to the male gland in the following order: polyethylene, leather, polyethylene, leather, polyethylene.
11. Take upper female gland & place on top of assembled upper packings with the inverted side down. 
12. Take assembled upper glands & packings (7 pieces) & slide on over the top of the piston, making sure inverted sides are down.

13. Take the packing holder & replace the white O-ring & the black O-ring with new ones from the packing kit.
14. Slide the packing holder over the top of the upper packings so they fit inside.
15. Lubricate inside of the fluid pump body & the outside of the packings with a light weight oil.
16. Slide assembly into fluid pump body.

TO KEEP PACKINGS SECURED IN CORRECT POSITION, HOLD THE PUMP BODY UPSIDE DOWN & PUSH THE COMPLETED ASSEMBLY UPWARDS INTO THE PUMP BODY. ONCE PLACED INSIDE, TILT PUMP BODY BACK UP TO KEEP ALL PIECES IN.

17. Tighten packing nut onto the top of the fluid pump body & tighten until you feel slight resistance against the Belleville Springs. Using the Packing Adjustment Tool, tighten another 3/4 of a turn.
18. Reinstall Fluid Pump as instructed on page 14.

FIG. 15 PARTS LIST ON FOLLOWING PAGE

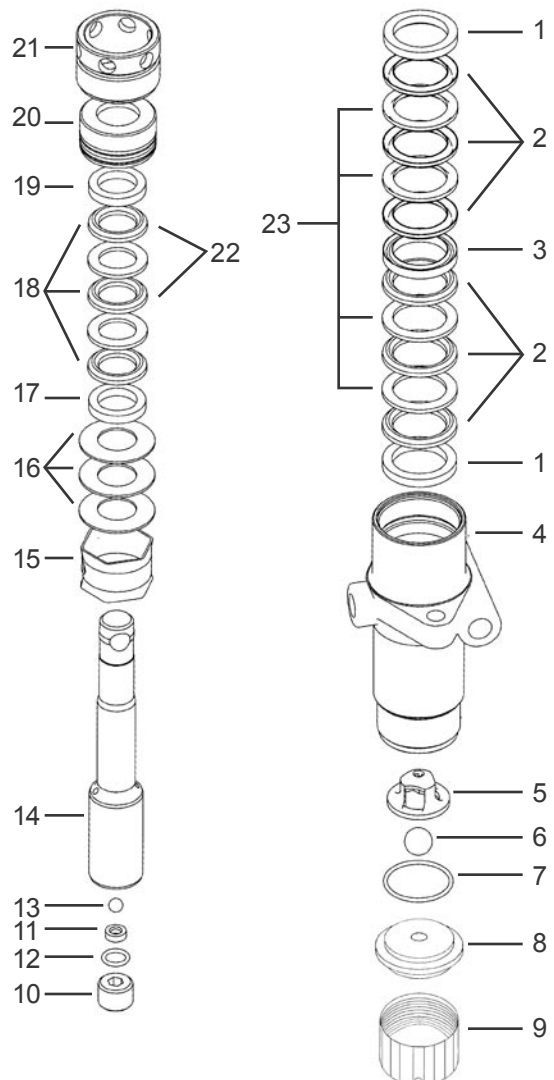

PACKING REPLACEMENT PROCEDURES

FIG. 16

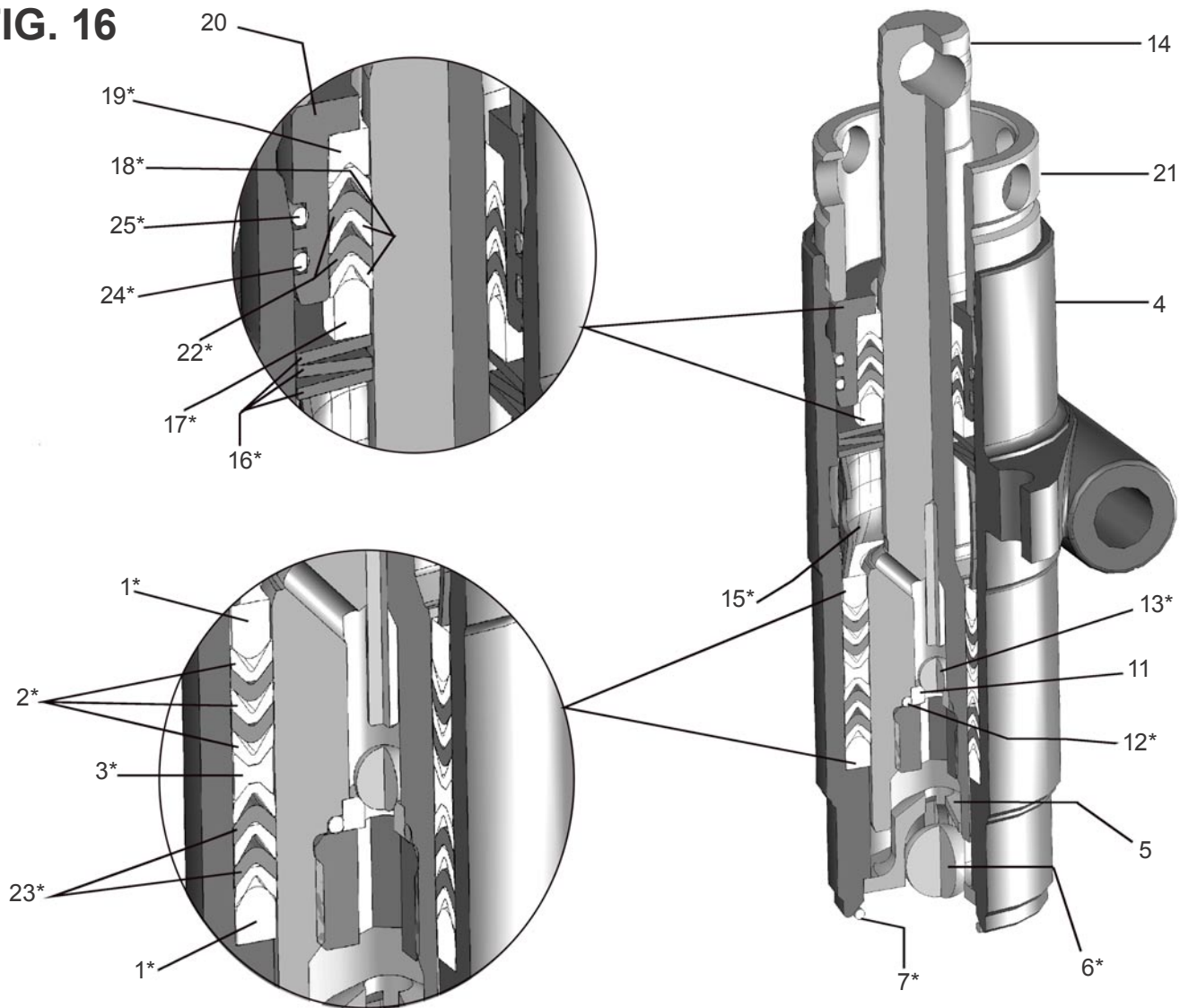

PARTS LIST FIGURE 15 & 16

Item No.	Part No.	Description
1	331-014*	Male Gland
2	331-016*	Packing Polyethylene
3	331-308*	Female Adaptor
4	331-011	Fluid Pump Body
5	331-029	Suction Ball Guide
6	331-030*	Suction Ball
7	106-011*	O-Ring
8	331-409	Suction Seat
9	331-034	Suction Nut
10	331-314	Outlet Seat Retainer
11	331-026	Outlet Seat
12	331-100*	O-Ring
13	331-027*	Outlet Ball

PARTS LIST FIGURE 15 & 16 CONT

Item No.	Part No.	Description
14	331-708	Piston
15	331-018*	Spacer
16	331-025*	Belleville Springs
17	331-022*	Male Gland
18	331-023*	Packing Polyethylene
19	331-021*	Female Gland
20	331-019	Packing Holder
21	331-037	Packing Nut
22	331-307*	Packing Leather
23	331-306*	Packing Leather
24	106-009*	White O-Ring
25	106-010*	Black O-Ring
*	331-210	Packing Kit

GEARBOX (305-341)

FIG. 17

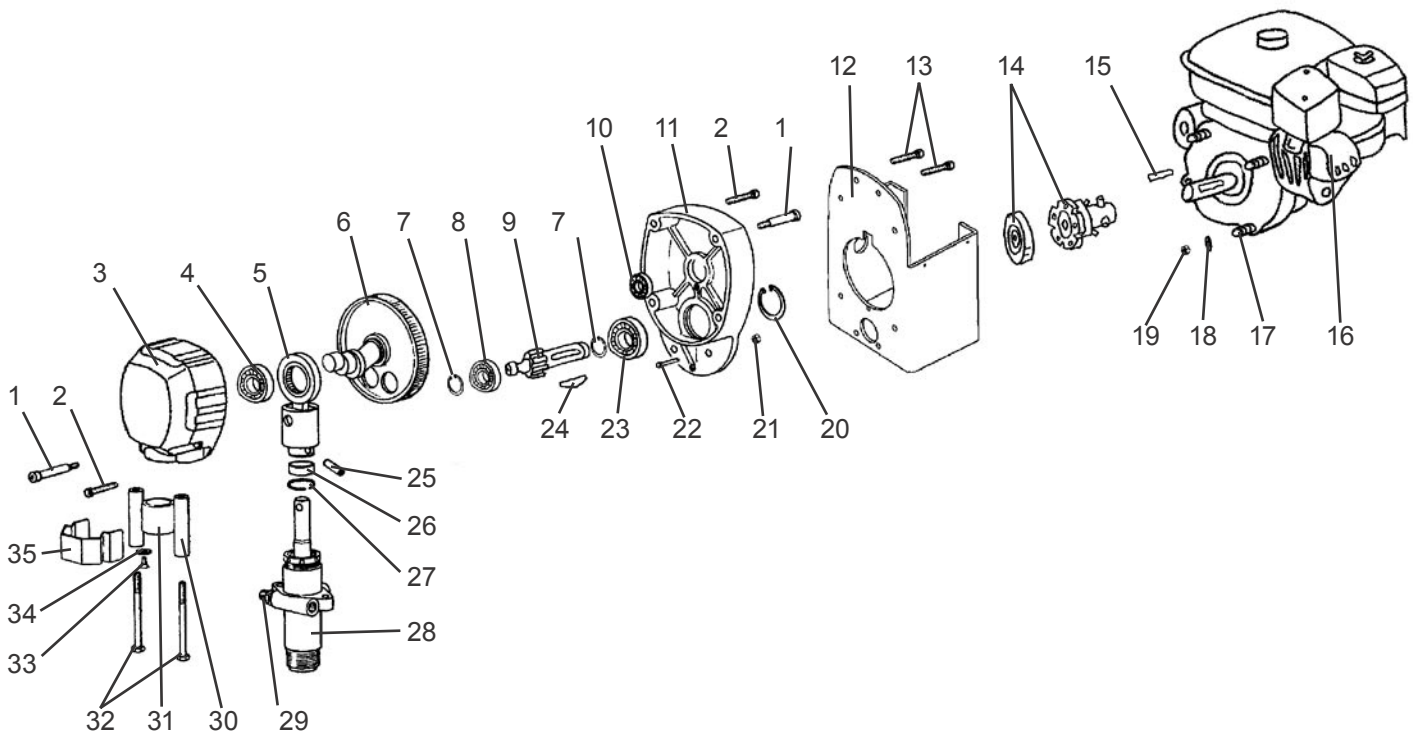

PARTS LIST FIGURE 17		
Item No.	Part No.	Description
1	100-380	Shoulder Screw (2)
2	100-381	Screw (2)
3	331-537	Cover
4	331-046	Ball Bearing
5	331-038	Crosshead Assy
6	331-408	Crank Assy
7	113-093	Retaining Ring (3)
8	112-068	Ball Bearing
9	305-340	Pinion Shaft
10	305-047	Ball Bearing
11	305-287	End Bell
12	305-342	Mounting Box Bracket
13	100-374	Screw (4)
14	301-666	Clutch Assy
15	112-029	Key
16	301-160 175-032	Motor Honda GX160 (SS400/FS +) Motor Duro 5.5HP (SS3650/FS D)
17	331-496	Set Screw (4)
18	113-023	Washer

PARTS LIST FIGURE 17 CONT		
Item No.	Part No.	Description
19	331-497	Nut (4)
20	100-398	Retaining Ring
21	136-217	Nut (2)
22	188-041	Screw(2)
23	117-008	Bearing
24	113-094	Key
25	119-028	Pin
26	331-117	Sleeve
27	331-062	Retaining Spring
28	331-209	Fluid Pump
29	115-019	Hose Connector
30	331-074	Spacer (2)
31	331-061	Sleeve Bearing
32	100-318	Scre (2)
33	331-197	Screw (2)
34	331-103	Washer (2)
35	331-111	Cover Guard
*	331-132	Grease (116)

CLUTCH ASSEMBLY

FIG. 18

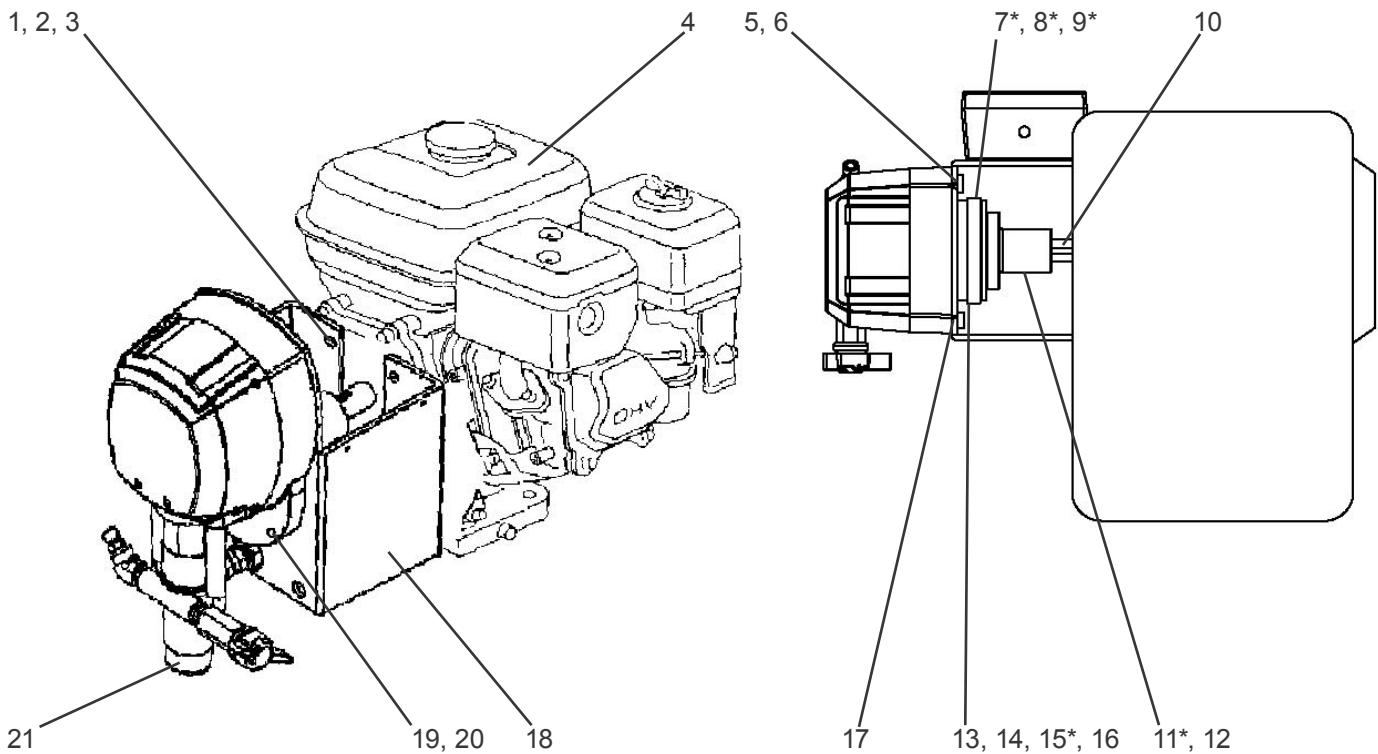

PARTS LIST FIGURE 18		
Item No.	Part No.	Description
1	331-496	Screw
2	331-497	Nut
3	113-023	Lock Washer
4	175-032	Motor Duro 4.0HP
5	111-016	Nylon Tie
6	100-637	Mounting Base
7	100-632*	Locknut
8	100-633*	Screw
9	100-634*	Lock Washer
10	112-029	Key
11	305-279*	Clutch Adapter

PARTS LIST FIGURE 18 CONT		
Item No.	Part No.	Description
12	331-495	Bushing
13	113-093	Retaining Ring
14	113-094	Key
15	305-278*	Clutch
16	331-178	Rubber Extrusion
17	100-374	Screw
18	305-342	Mounting Box Bracket
19	136-217	Nut
20	188-041	Screw
21	305-310	Gearbox and Pump Assy
*	301-666	Clutch Assy

FRAME ASSEMBLY (305-411)

FIG. 19

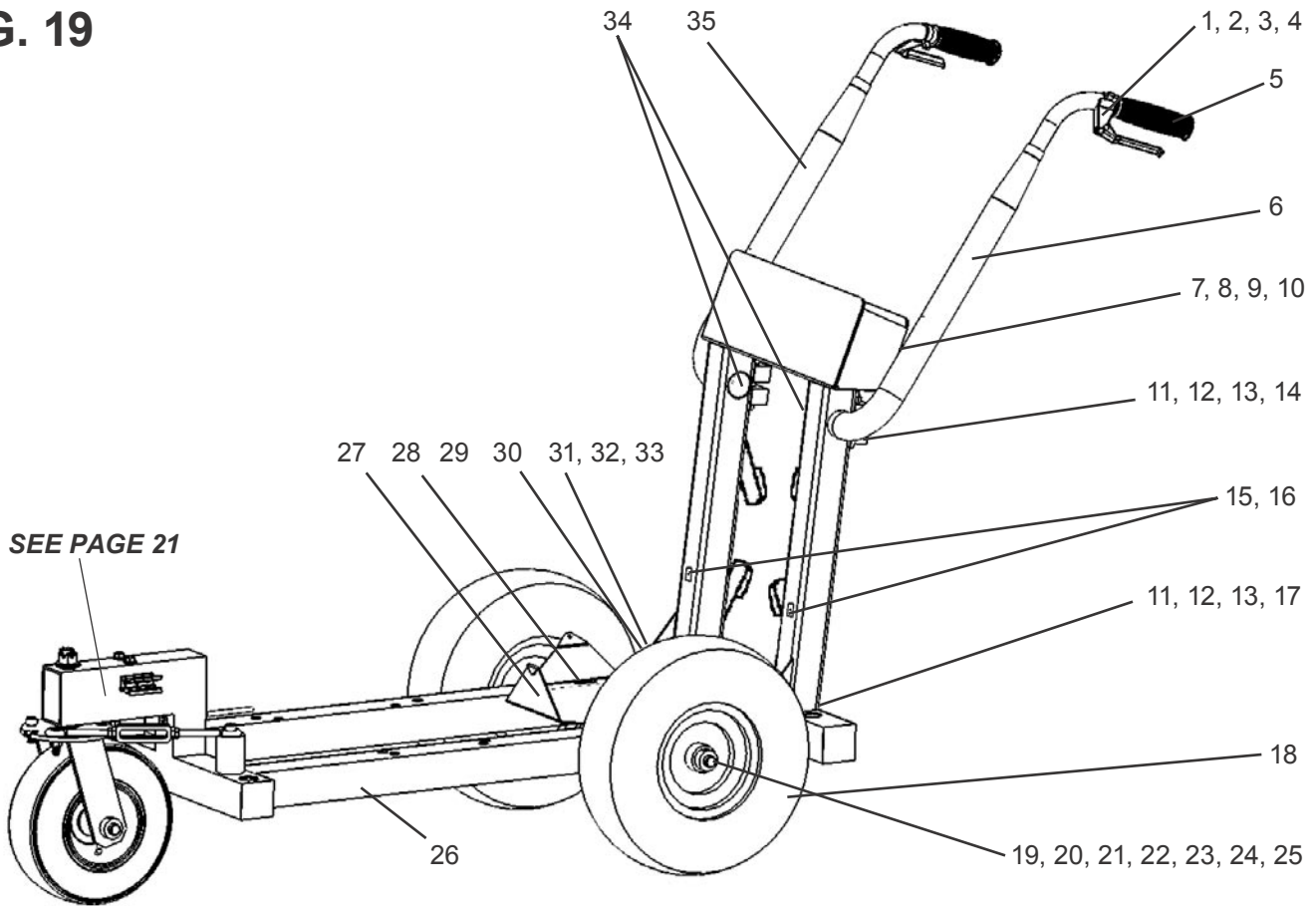

PARTS LIST FIGURE 19

Item No.	Part No.	Description
1	136-023	Cable End Lug
2	301-335	Shrink Tubing (2)
3	305-089	Cable Insert
4	305-105	Lever
5	305-058	Rubber Grip (2)
6	305-314	Handle Weldment (Left)
7	113-022	Nut (2)
8	100-686	Paint Hose Hook (4)
9	100-344	Washer (4)
10	100-360	Screw (4)
11	100-696	Nut (2)
12	140-034	Washer (2)
13	140-035	Washer (2)
14	100-695	Screw (2)
15	100-687	Two Channel Strap (3)
16	100-688	Screw (3)
17	139-327	Rivnut (2)
18	301-166	13" Wheel

PARTS LIST FIGURE 19 CONT

Item No.	Part No.	Description
19	188-367	Axle
20	100-369	Wave Washer (2)
21	113-030	Spacer (2)
22	136-131	Chain Sash
23	136-133	Key Ring
24	143-029	Set Collar (2)
25	143-028	Washer (2)
26	305-395	Frame
27	305-396	Bucket Base
28	119-026	Screw (3)
29	305-428	Stop
30	100-621	Cap
31	188-042	Lock Nut (4)
32	305-185	Brake Clamp
33	100-390	Screw (4)
34	100-601	Plug (2)
35	305-315	Handle Weldment (Right)

SWIVEL WHEEL ASSEMBLY

FIG. 20

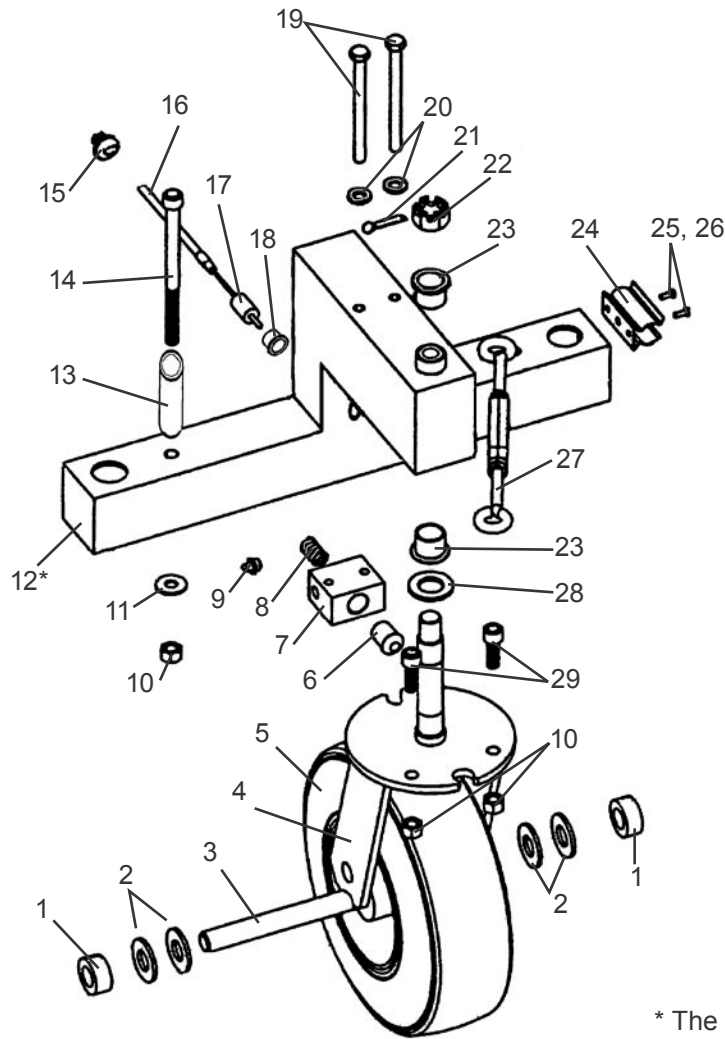

* The swivel wheel weldment is part of the entire stripper frame weldment.

PARTS LIST FIGURE 20

Item No.	Part No.	Description
1	143-029	Set Collar (2)
2	143-028	Washer (4)
3	136-230	Axel
4	305-253	Swivel Clamp
5	139-337A	Wheel
6	305-257	Swivlel Lock Pin
7	305-258	Swivel Lock
8	136-223	Spring
9	100-223	Grease Fitting
10	119-035	Nut (4)
11	100-344	Washer (2)
*12	305-395	Frame Weldment
13	179-029	Spacer (2)
14	100-648	Screw (2)
15	305-261	Cabel Holder

PARTS LIST FIGURE 20 CONT

Item No.	Part No.	Description
16	100-652	Cable
17	305-259	Lock End Lug
18	305-141	Cable Adjustor
19	100-318	Screw (2)
20	113-023	Washer (2)
21	113-021	Cotter Pin
22	260-029	Hex Castle Nut
23	112-008	Flanged Bearing (2)
24	111-036	Spring Clamp
25	140-040	Washer (2)
26	117-072	Screw (2)
27	136-231	Turnbuckle
28	140-053	Washer
29	100-649	Screw (2)

GUN ASSEMBLY (305-167)

FIG. 21

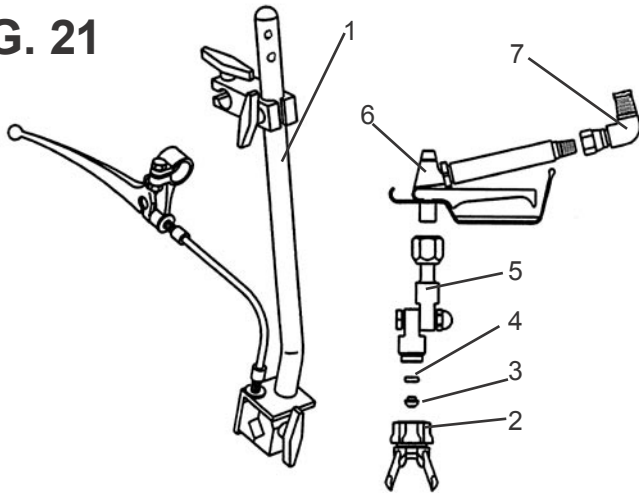

PARTS LIST FIGURE 21

Item No.	Part No.	Description
1	305-150	Gun Holder
2	561-002	RevGuard (G Thread)
3*	561-025	Seal-Metal
4*	561-026	Seal-Plastic
5	032-028	Swivel Assembly
6	120-554	008 Airless Gun
7	100-177	Elbow
*	561-029	Seal Kit

GUN HOLDER ASSEMBLY (305 - 150)

FIG. 22

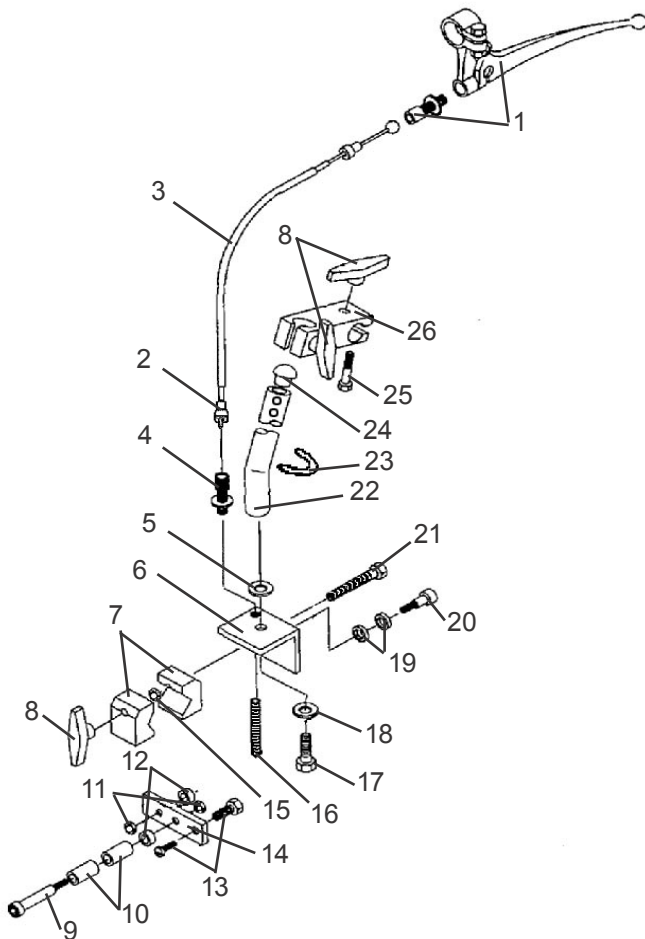

PARTS LIST FIGURE 22

Item No.	Part No.	Description
1	305-142	Lever Assy.
2	305-089	Cable Insert (2)
3	100-685	Gun Cable Assy.
4	305-141	Cable Adjuster
5	111-052	Tube Connector
6	305-154	Bracket
7	305-152	Clamp (2)
8	305-157	Knob (3)
9	100-342	Screw
10	305-159	Sleeve Bearing (2)
11	140-045	Jam Nut (2)
12	305-161	Spacer (2)
13	305-079	Wire Swivel Assy.
14	305-155	Lever
15	140-051	Nut
16	116-100	Spring
17	169-050	Screw
18	113-027	Lock Washer
19	305-156	Thrust Washer (2)
20	305-158	Shoulder Screw
21	100-673	Screw
22	305-297	GS Holder
23	116-105	Spring Clip
24	143-027	Ball Guide
25	171-008	Screw (2)
26	136-019P	Swivel Clam Assy.

PAINT SYSTEM

FIG. 23

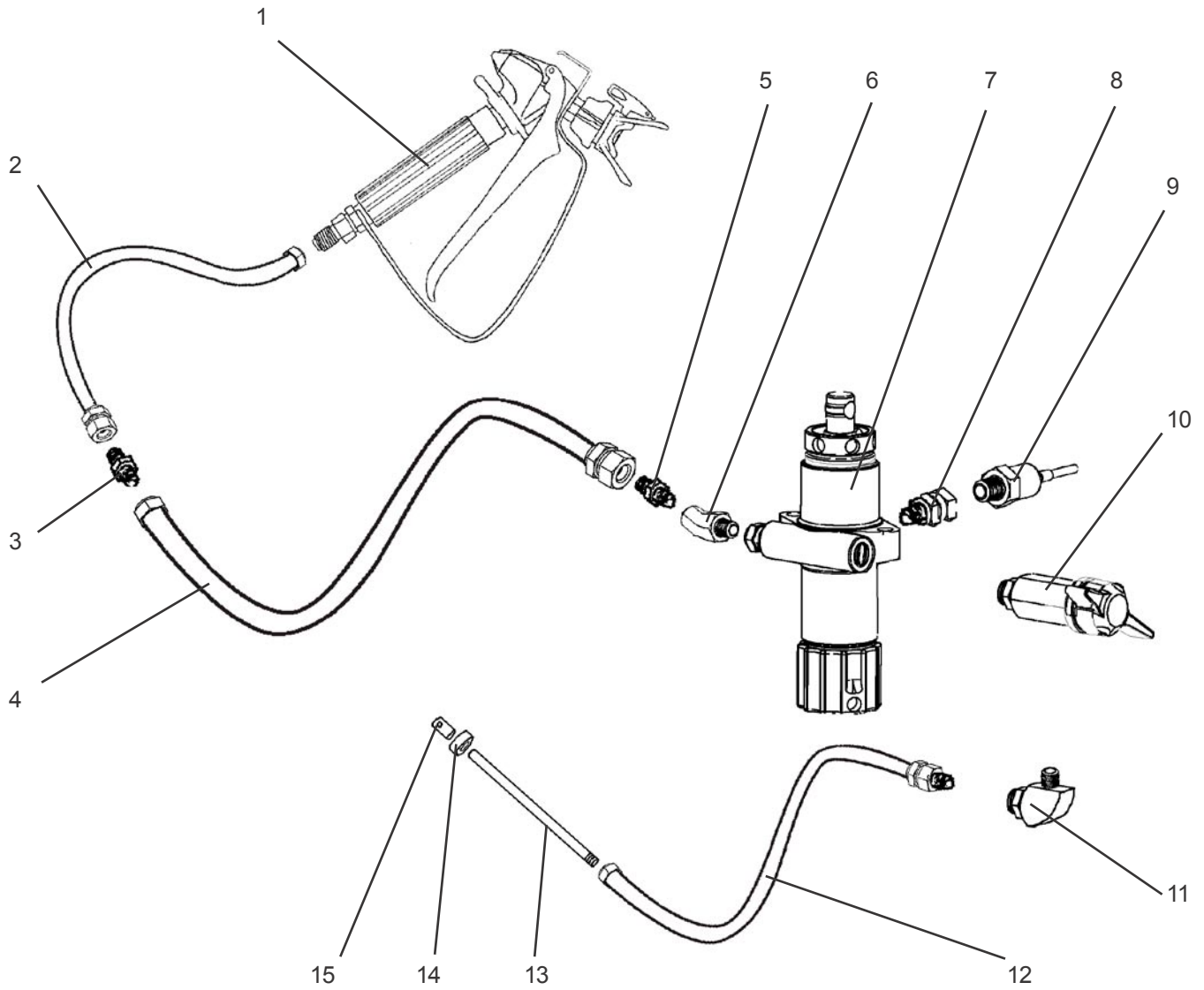

PARTS LIST FIGURE 23		
Item No.	Part No.	Description
1	120-554	008 Airless Gun
2	100-011	Hose 50' x 1/4"
3	100-109	Nipple 3/8" x 1/4"
4	100-199	Hose 6' x 3/8"
5	115-019	Connector
6	100-226	Elbow 45°
7	331-209	Fluid Pump
8	100-603	Swivel

PARTS LIST FIGURE 23 CONT		
Item No.	Part No.	Description
9	331-294-99	Sensor
10	100-180	Prime Valve
11	100-660	Elbow 1/8" x 1/4"
12	100-012	Hose 4' x 1/4"
13	188-373	Return Pipe
14	305-293	Reflector
15	100-642	Gasket

SUCTION ASSEMBLY (331-238)

FIG. 24

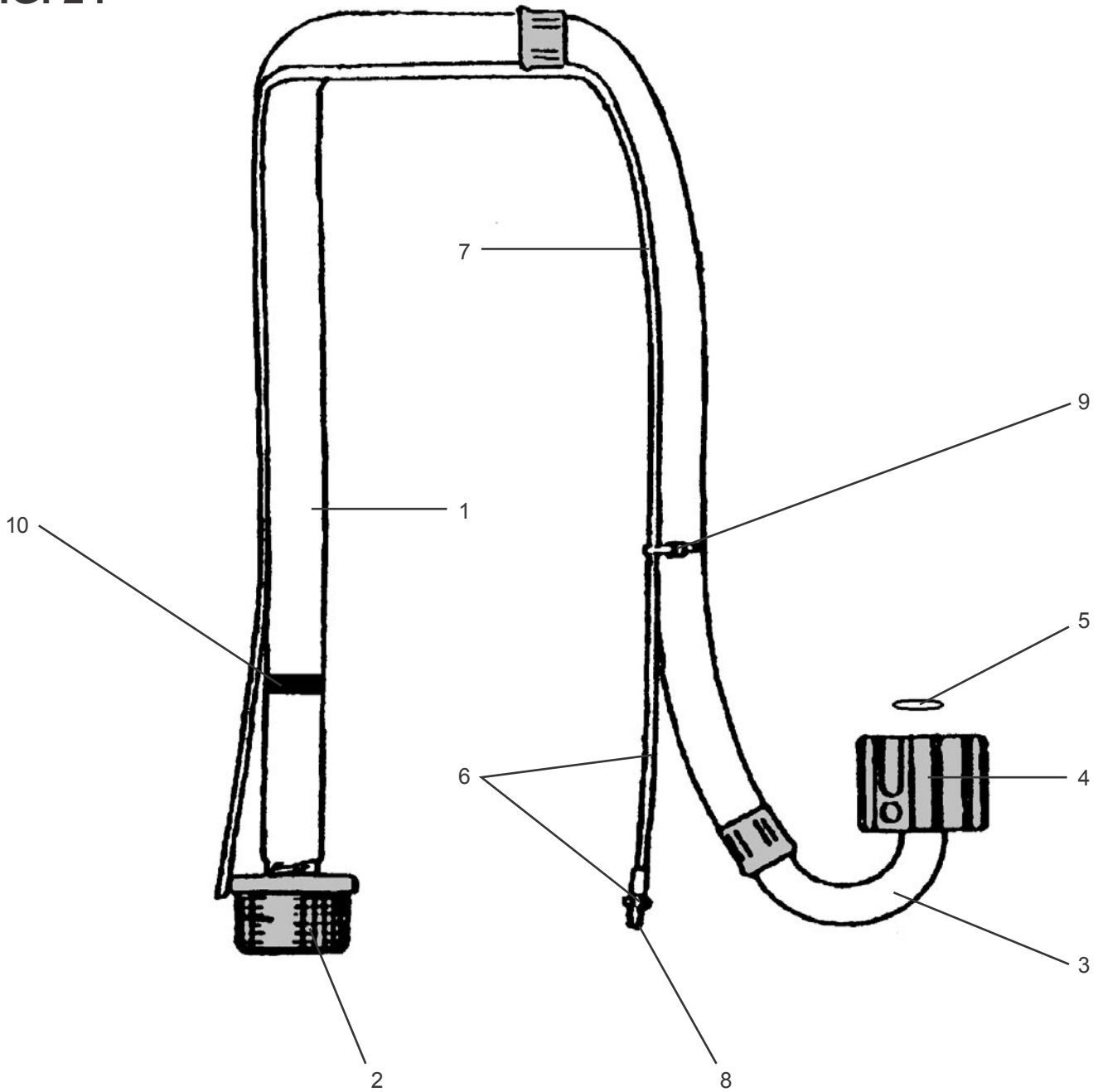

PARTS LIST FIGURE 24		
Item No.	Part No.	Description
1	331-290	Suction Hose Assy
2	331-217	Inlet Strainer
3	331-035	Suction Elbow
4	331-034	Suction Nut
5	106-020	PTFE O-Ring

PARTS LIST FIGURE 24 CONT		
Item No.	Part No.	Description
6	331-231	Bypass Hose Assy
7	331-425	Bypass Hose
8	331-090R	Fitting
9	111-016	Nylon Tie
10	331-135	Spring Clip

DUAL WHEEL FLOATING GUN ASS'Y - FS D/+

FIG. 25

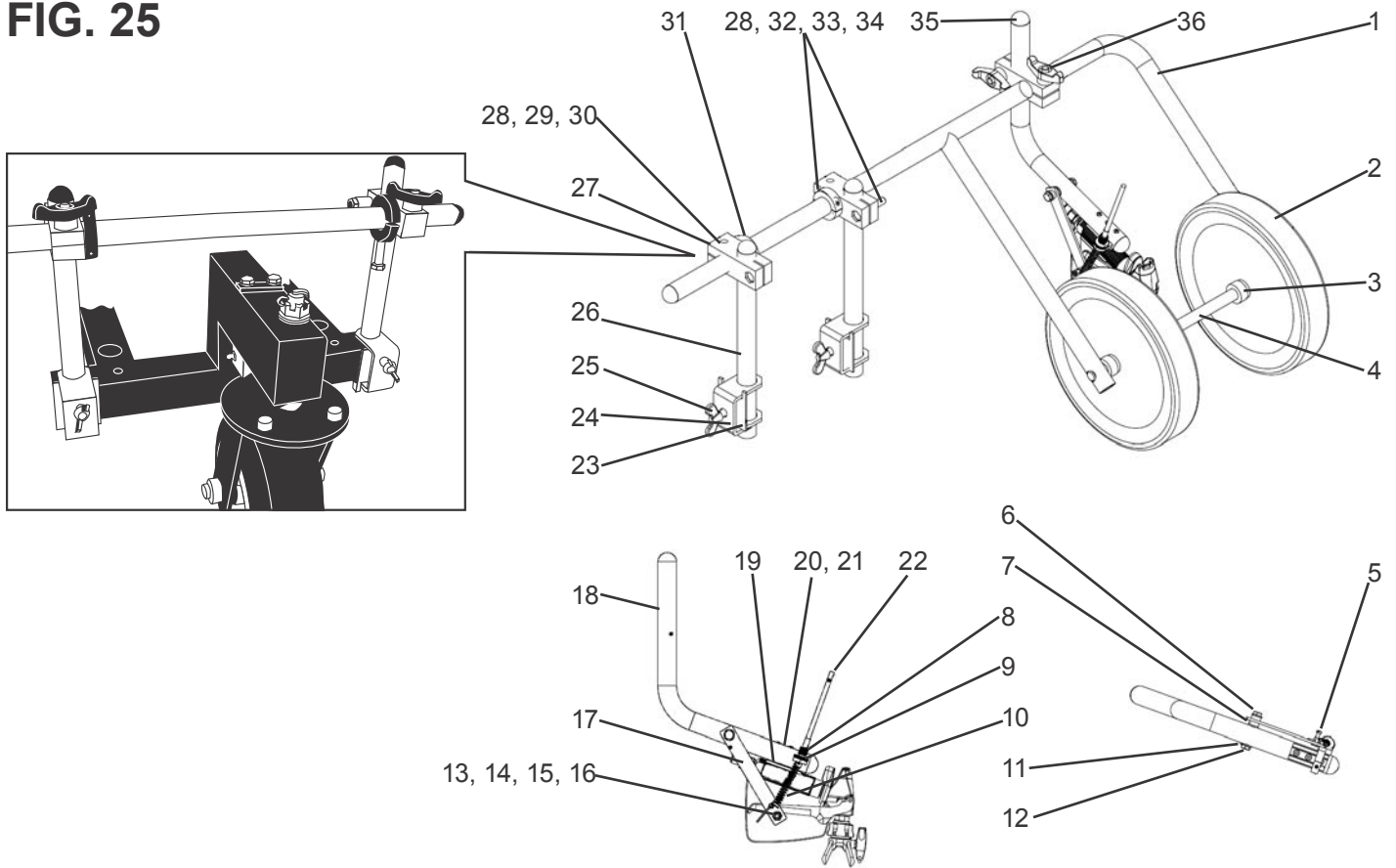

PARTS LIST FIGURE 25		
Item No.	Part No.	Description
1	305-352	Mounting Tube
2	305-367	Wheel (2)
3	143-029	Set Collar (4)
4	305-351	Axel
5	305-079	Wire Swivel Assy.
6	119-049R	Screw
7	305-273	Spacer (2)
8	305-089	Cable Sleeve
9	305-141	Cable Adjustor
10	116-100	Compression Spring
11	331-103	Washer (3)
12	136-217	Nylon Lock Nut
13	100-342	Screw, 5/16
14	305-161	Spacer
15	305-159	Sleeve Bearing (2)
16	140-045	Nut
17	305-274	Trigger Lever
18	305-243	Gun Holder Tube
19	119-276	Spring Clip

PARTS LIST FIGURE 25 CONT		
Item No.	Part No.	Description
20	119-052	Lock Nut (2)
21	305-050R	Screw (2)
22	305-077	Cable Assy.
23	305-108	Clamp Plate (2)
24	305-051M	Clamp (2)
25	100-320	Wing Screw (2)
26	305-292	Support Tube (2)
27	136-019P	Swivel Block (3)
28	140-051	Nut (4)
29	140-035	Lock Washer (3)
30	188-125	Screw, 3/8 HX (3)
31	136-039R	Set Collar
32	136-039	Set Collar
33	171-088	Screw 3/8 (4)
34	188-378	Spacer
35	143-027	Ball Guide (5)
36	305-157	Knob - SG Holder Assy.
37	305-142	Hand Lever (Not Shown)

REPLACEMENT OF ELECTRICAL CONTROL BOARD

1. Remove electrical cover.
2. Disconnect sensor lead from Electrical Board.
3. Disconnect two clutch leads on Electrical Board from leads on clutch.
4. Using a 1/16" allen, loosen set screw in Pressure Control Knob and remove knob.
5. Using a 1/2" nutdriver or 1/2" deep socket, remove nut from pressure control shaft. This will allow removal of electrical control board from frame.
6. Replace Electrical Board Assembly in reverse order. Adjust pressure as per procedure below, "Pressure Calibration on the Electrical Control Board".

PRESSURE CALIBRATION OF THE ELECTRICAL CONTROL BOARD

1. Turn "Pressure Calibration" Trimpot adjustment on electrical control board in the counter clockwise direction at least 15 revolutions.
2. Connect 5000 psi glycerine pressure guage on outlet of pump between fluid pump & airless hose to monitor Fluid Pump Pressure.
3. Start engine and run at maximum RPM. Turn Prime Valve to the open (Prime) position. Turn Pressure Control Knob to maximum position (fully clockwise).

4. Using an insulated screwdriver, adjust "Pressure Calibration" Trimpot by turning clockwise until the clutch engages. When the clutch engages the pump will commence Priming. When pump is primed, turn the Prime Valve to the Closed (Pressure) Position.

THE PUMP WILL BEGIN TO PRESSURIZE AND THE CLUTCH WILL DISENGAGE AT A LOW PRESSURE. CONTINUE TURNING THE TRIMPOT CLOCKWISE TO INCREASE PRESSURE TO 3000 PSI.

5. Trigger gun. The pressure should drop approximately 350-400 psi, the clutch will engage and build pressure to 3000 psi and disengage. Trigger gun several times to ensure proper pressure setting.
6. Turn Pressure Control Knob to minimum position. The clutch should disengage and pump stop moving.
7. Secure leads with tie strap.
8. Replace cover on unit. Ensure the leads are not pinched or damaged in the process of replacing covers.

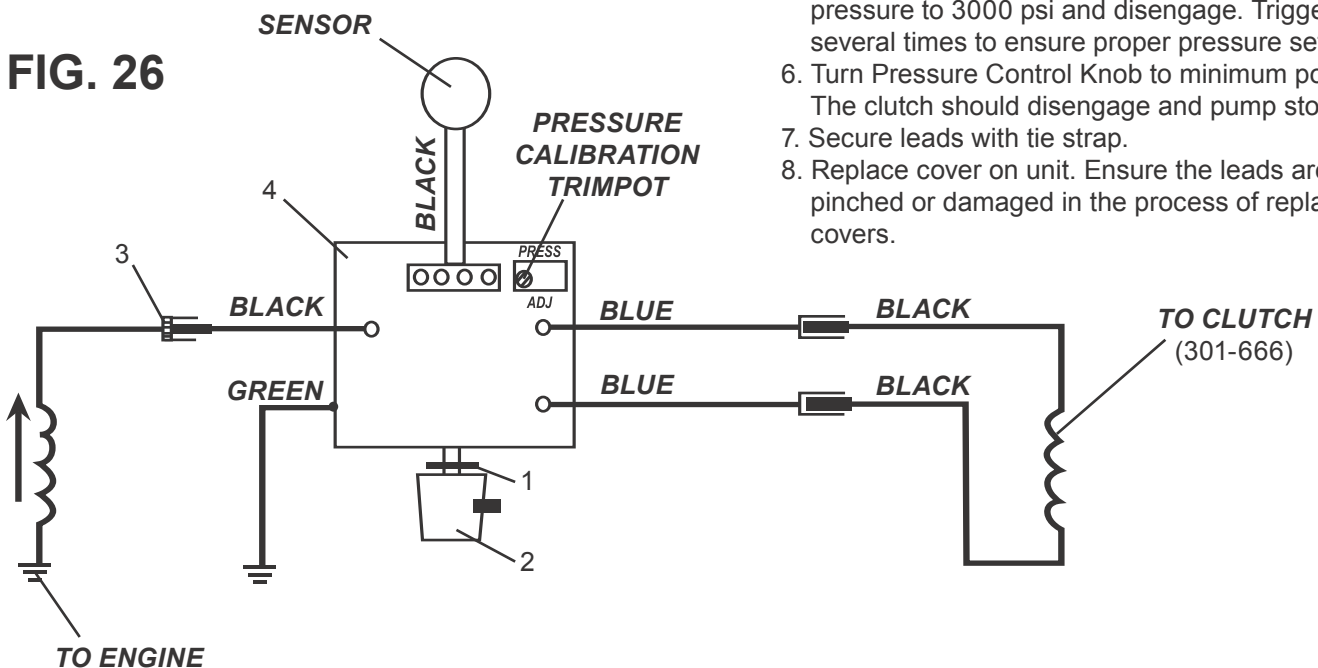

PARTS LIST FIGURE 26

Item No.	Part No.	Description
1	106-019	O-Ring
2	301-523A	Knob
3	117-045	Grommet
4	301-282-99	Control Board

ELECTRICAL TROUBLESHOOTING - Clutch Does Not Engage

STEP 1: Ensure that the pressure control knob (POT) is in the maximum (CW) position.

STEP 2: Remove the clutch and electrical box covers.

STEP 3: Check all electrical connections between the engine magneto, sensor, control board and clutch for loose connections or damaged leads.

STEP 4: Disconnect the two leads from the control board (blue) and the clutch assembly (black). Using a multimeter, with the engine at maximum RPM, pressure control knob in the maximum position and the prime valve open (priming) position, test the DC voltage across the boards leads (blue). This voltage must be 13-14 VDC. If the readings are correct, the board, sensor and magneto are okay and the problem is the clutch assembly. If this is the case, proceed to Step 5. If the voltage is outside this range go to Step 7.

STEP 5: Check the spacing between the clutch field and plate. The gap should be a maximum of .010". If the gap is greater than .010" the gap is too wide. If this gap is too wide, replace the clutch assembly.

STEP 6: When the DC voltage from the board is not 13-14 VDC, disconnect the control board lead (black) from the engine magneto lead (pink), located on the side of the engine. With the engine at maximum RPM (3600), pressure control knob in maximum (CW) position and prime valve open (priming), read the AC voltage from the magneto lead to the sprayer frame. This reading should be 19-24 VAC. If outside this range, contact your local small engine repair facility for magneto replacement. If the magneto is producing the proper AC voltage, continue to Step 7.

STEP 7: Test the sensor by reading the resistance between the red and black wires. The resistance runs between 1.5-3K ohms. A defective sensor usually shows no resistance (open). If the reading is outside standards, replace the sensor. An alternative method to test the sensor, is to plug a new sensor into the board and see if the clutch will engage. Caution! When using this method, ensure prime/pressure valve is in the prime position. This is important because the sensor plugged into the board is not measuring pressure in the fluid section.

STEP 8: When Steps 6 & 7 have been completed and the magneto and sensor check good, the electrical control board is the only item left, replace the board.

STRIPING ACCESSORIES

STENCIL KIT

For use on any single gun striper for stencilling or spraying paint. Includes a 2nd gun, 50' of 1/4" airless hose, 18" extension pole & shut-off ball valve.

PART # 305-399



12GAL CONTAINER

High capacity plastic paint bucket

PART # 189-006



FLOATING SPRAY GUN KIT

Upgrades any Airlessco striper to a floating gun mount for consistent width lines on bumpy, uneven surfaces like sports fields. Wheels provide added wind protection for spray pattern.

PART # 305-355. (PATENT PENDING)

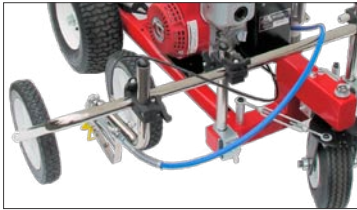

POINTER

For easy line-up and striping of long lines.

PART # 136-069

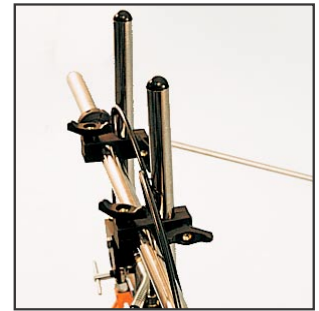

BEAD DISPENSERS

Gravity type glass bead dispenser kits.

1 GUN 4" PN 305-174

1 GUN 4-6" PN 305-186

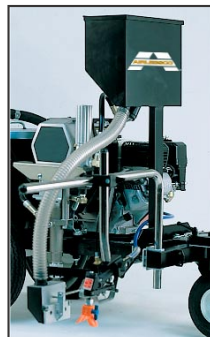

Quick Flush™

- The only clean water flushing system
- Cuts sprayer clean-up time in half!
- Connects to standard garden hose to backflush sprayer through gun
- Includes "F" and "G" adapters to work with all brands of gun

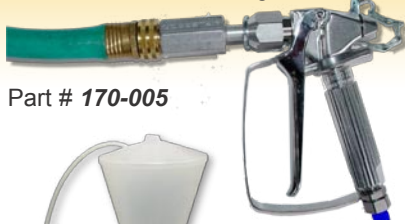

Part # 170-005

PAINT HOPPER

For use on small jobs where paint is kept in smaller than 5 gallon containers. Threads onto pick-up tube of carry or LoBoy framed Airlessco sprayers.

331-775 6 Liter Paint Hopper



PUMP CONDITIONER

Should be used on piston pumps between uses to prevent paint from drying on the piston & causing packing wear.

010-001 Display of 48 - 1 oz. bottles
 010-009 1 quart bottle
 010-019 1 Gallon bottle

Case quantity: 12 on quarts, 4 on gallons



PAINT STRAINERS

Pre-filter your paint using strainer bags. One dozen per pack.

100-064 Used to cover suction filter
 100-065 5 Gallon strainer



HOSE COVER

4 mil poly protects your airless hose from paint and abrasion damage. Comes in 1000' roll with perforations every 50'.

100-219 Hose Cover Roll
 100-426 Case of 6 Rolls



HIGH PRESSURE AIRLESS HOSE

Strong yet flexible, for airless sprayers up to 3300 PSI

Part No:	Hose Description
100-012	3/16" Whip Hose, 4 Ft.
100-040	1/4" Whip Hose, 3 Ft.
100-204	1/4" Whip Hose, 5 Ft.
100-199	3/8" Whip Hose, 6 Ft.
100-011	1/4" Hose, 50 Ft.
100-023	3/8" Hose, 50 Ft.
100-037	1/2" Hose, 50 Ft.
100-010	1/4" Hose Connector
100-009	3/8" Hose Connector



STAY CLEAN™

Spray protectant for machine to prevent paint from sticking to it. Keeps your sprayer looking new for years!

114-030 20 oz. can
 Case quantity: 12 cans



THROAT SEAL OIL

Used in the wet cup of a piston pump to prevent paint from drying on the piston & causing damage to the upper packing. Use with all piston pumps.

188-187 6 oz. Bottle
 188-392 1 qt. Bottle



XTEND-A-POLE SYSTEM

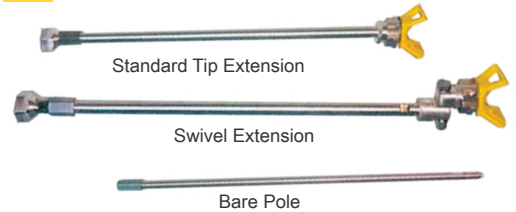

STANDARD TIP EXTENSION, "G" Thread

032-170 6" Long
 032-171 12" Long
 032-172 18" Long
 032-173 24" Long

SWIVEL EXTENSION, "G" Thread

032-184 36" Long

BARE POLE

Add Tip Extension or Swivel Extension to create desired length

032-053 24" Long
 032-054 36" Long

SWIVEL "G" THREAD

032-035-55 7/8" x 14 Swivel



ADAPTERS

- 90° Pole to Gun Adapter
032-042
- Gun Nut "F" Thread 11/16-16
032-010
- Gun Nut "G" Thread 7/8-14
032-011
- "F to G" Gun adapter to attach Graco® tips to Airlessco guns.
032-012

