

ATOMEX™

XM-45 XM-56 XM-68
Pneumatic Airless Sprayers



45:1 Ratio Air Powered XM Pump

4500 psi (310 bar) MAXIMUM FLUID WORKING PRESSURE

Part Number: AX/0F-XM-45

56:1 Ratio Air Powered XM Pump

5600 psi (386 bar) MAXIMUM FLUID WORKING PRESSURE

Part Number: AX/0F-XM-45

68:1 Ratio Air Powered XM Pump

6800 psi (468 bar) MAXIMUM FLUID WORKING PRESSURE

Part Number: AX/0F-XM-45



INSTRUCTION MANUAL



XM-Series Pneumatic Airless Sprayers

Table of Contents

Gun Information	4
Gun Maintenance	5
Airless Paint Hose	6
Airless Gun Tips	7
Operation Procedure	13
Clean Up & Maintenance	14
Troubleshooting	15
Parts Breakdown	16
Gun Manual	26

Description

Airless paint sprayers are capable of spraying a wide variety of latex, oil based, and water based paints, as well as stains, preservatives and other non-abrasive finishes.

These sprayers are powerful and versatile enough to be used with a variety of accessories to make them more efficient.

NOTE: Guns pictured in illustrations may be different to the one included with your unit.

Safety Guidelines

This manual contains information that is very important to know and understand. This information is provided for your SAFETY and to PREVENT EQUIPMENT PROBLEMS. To help recognize this information, observe the following symbols.



Indicates accident risk or damage to equipment if this warning is not followed.



Indicates fire or explosion risk if this warning is not followed.



Indicates wound and finger squashing risk due to movable parts in the equipment.

Unpacking

After unpacking the unit, inspect carefully for any damage that may have occurred during transit. Make sure to tighten fittings, bolts, etc. before using the unit.



Do not operate a damaged unit, as it may result in a malfunction which can cause injury and/or property damage.

General Safety

Read all manuals included with this product carefully. Be thoroughly familiar with the controls and the proper use of the equipment.

Always wear a mask or respirator and eye protection when painting.

Keep visitors away and NEVER allow children or pets in the work area.

We advise the use of this equipment only by professional operators. Only use this machine for usage specifically mentioned in this manual.

Application Chart

Coating	Can Use	Do Not Use	Tip Size	Spray Pressure
Oil Base Stain	x		.011-.013"	1500+ Psi
Wood Sealer	x		.011-.013"	1500+ Psi
Concrete Sealer	x		.011-.013"	1500+ Psi
Enamel	x		.011-.013"	2000+ Psi
Varnish	x		.011-.013"	2000+ Psi
Non-Metal-Flake-Aluminum Paint	x		.011-.017"	2000+ Psi
Vinyl Latex Paint	x		.013-.017"	2000+ Psi
Vinyl/Acrylic Latex Paint	x		.013-.017"	2000+ Psi
Acrylic Latex Paint	x		.013-.017"	2000+ Psi
Oil Base Paint	x		.013-.017"	2000+ Psi
Oil and WaterBased Primer	x		.013-.017"	2000+ Psi
V.V/A&ALatex Stain	x		.013"	2000+ Psi
Textured Coatings		x	N/A	
Elastomers		x	N/A	
Asphalt Coating		x	N/A	
Wood Restorer		x	N/A	
lock Filler		x	N/A	



AIRLESS PAINT SPRAYING WHAT IS IT?

What is Airless Paint Spraying?

As the names suggests, airless paint spraying allows paint and other related material to be sprayed without the use of compressed air. The spray action is caused by pumping the material at extremely high pressures through a small opening at the tip of an airless spray gun. The high velocity with which material passes through the nozzle causes it to atomize into fine spray while maintaining sufficient momentum to carry the particles to the surface. This process is known as atomisation.

An example of what is actually occurring can be ascertained when one watches water from the garden hose pass through a nozzle. Because the nozzle opening is much smaller than the fluid passage in the hose, there is a build-up of pressure which causes the water to separate into a fine spray when it is released. Due to the low viscosity of water, this is accomplished at very low pressure (40 PSI). Paint and other coating materials, however, have much higher viscosities, requiring higher pressures (1,000 - 3,000 PSI) to separate the particles and allow atomisation. Therefore, the key elements in an airless system are pressure, and a small opening to increase the velocity of the material which thereby creates atomisation.

Why Airless Paint Spraying?

The combination of high pressure and the precise opening in the nozzle (which defines the spray pattern) allows the operator to apply coatings at maximum efficiency with very little over-spray. A second coat is quite often not required due to the uniform coverage achieved by airless spraying.

EFFICIENCY

IMPROVED PRODUCTION CAPABILITIES

INCREASED PROFITS



ATOMEX X-750 FEATURES AND BENEFITS

Professional Airless Gun

Versatility, Durability and Comfort for the Painting profession.

The ATOMEX X-750 professional airless spray gun has been designed to meet the heavy, daily requirements of professional painting contractors. Lightweight and comfortable, the ATOMEX X-750 provides effortless control and minimises the hand fatigue that often results from working house after hour.

- Metal construction to withstand daily use
- In-handle filter reduces clogging and increase tip life
- Self-cleaning, reversible tip eliminated tip clogs
- A tungsten carbide ball valve and seat
- A tungsten carbide ball bearing swivel
- Light four-finger pull for comfort and trigger guard and safety lock for added protection
- Lightweight - just 650 grams. Accepts any tip, pole extension, power roller or a universal swivel without an adaptor.



Technical Information

- Pressure rated @ 7500 PSI, 515 BAR
- Weight: 650 grams
- 1/4" inlet
- Tungsten carbide ball value and swivel
- Comes equipped with a X-75HD Tip
- Comes equipped with a 60 mesh filter
- Product No. AX/02-750-000



ATOMEX X-750 COMMON QUESTIONS

Can I use the ATOMEX X-750 with another manufacturer's airless spray painting unit?

Yes. The ATOMEX X-750 can be used with any airless spray painting unit. However, be certain not to exceed recommended pressure ratings of 7500 PSI.

Can the on-off valve in the ATOMEX X-750 be replaced?

Yes. The procedure is quite simple and is outlined under Installation and Service in this section. It also is included on each instruction sheet.

Can other types of airless tips be used?

Yes. They accept any tip, extension or pressure roller.

MAINTENANCE AND CLEANING

1. Cleanliness is important to assure trouble free operation. Flush unit after each use.

! WARNING

Important: When flushing, always remove tip, adjust pressure to lowest possible setting, and hold gun firmly against metal container to prevent static sparking. Use only metal containers.

2. Trigger can be placed in a lock-on position by pulling trigger and rotating safety lock towards back of gun. Important: This lock-on feature should never be used while spraying. Use for flushing only, when tip is removed and pressure is adjusted to lowest possible setting.

! CAUTION

3. Store clean unit in a dry place. Do not leave in water or solvents.

AIRLESS PAINT HOSE

Construction

- Flexible polyurethane cover, textile & wire braid reinforcing allows for expansion and contraction
- Nylon inner core to resist solvents and absorption
- Continuous conductive core provides grounding
- Permanent end couplings
- 7500 p.s.i. working pressure
- 13,200 p.s.i. burst pressure
- Do not use hose other than proper airless paint spraying hose which **MUST** be continually conductive.



Hose Length

- Paint hose available in 15m lengths with optional lengths on request
- A minimum of 15m paint hose must be used on Atomex sprayers (serves as buffer or pressure accumulator - use of shorted paint hose results in pulsations).



UNDERSTANDING AIRLESS TIPS

Airless tips are a key component to the successful operation of an airless system. They define the spray pattern, control the flow and ultimately tell each pump how hard it must work. Airless tips are available in many different styles, each offering an assortment of fan widths and orifice sizes (actual opening measured in thousandths of an inch). The orifice size determines the amount of fluid to be sprayed while the shape of the orifice determines the fan width. The orifice is always elliptical in shape and therefore creates a similarly shaped spray pattern. The more elongate the orifice, the wider the spray pattern.

Airless Tip Care

Due to the small opening (orifice) in an airless tip (approximately half the diameter of a pin), tip plugs can present a problem. Therefore, it is essential to always clean the equipment properly, strain the paint and always use pumps and guns which incorporate filters. Additionally, a self cleaning tip is always recommended.

The high pressure generated by airless requires that the tip be constructed of tungsten carbide. Although extremely hard, tungsten carbide is brittle. Therefore, a sharp object such as a nail should never be used to probe an airless tip while cleaning or to remove a clog. Always clean an airless tip in solvents with a soft bristle or compressed air. And store in a dry area.

Tip Selection

Proper tip selection is critical to the success or failure of the airless system. It is therefore essential to understand the method of referencing the orifice and fan width. Although there are several different numbering systems utilised by different manufacturers, remember that each in its own way will identify the orifice and fan width. The most common method of identification works as follows.

517

The first digit (5) indicates 1/2 of the minimum fan width. Add 2" for maximum fan width. (5 = a 10" to 12" pattern while spraying 12" from surface)

The last two digits (17) indicates the equivalent orifice size: (17 = 0.017) Measured in thousandths of an inch.



EXAMPLES

The larger the orifice with the same fan width, the greater the volume of paint applied to the same area.

Fan Width:	10"	10"	10"
Orifice Size:	0.017	0.021	0.026
Tip No.	517	521	526
	Least volume	More volume	Most volume

Conversely, the larger the fan width with the same orifice means the same amount of material is being applied of a greater area. The result is less volume per square inch.

Fan Width:	8"	12"	16"
Orifice Size:	0.017	0.017	0.017
Tip No.	417	617	817

As the fan width becomes more elongated, the fan width increases and tip plugs become more commonplace.

Fan width:	10"	16"	more
Tip No.	517	817	susceptible to clogging

Light bodied materials such as lacquer and stains will most commonly be used with smaller orifice tips. Heaver bodied materials will require large orifice openings.

The following chart indicates the most common sizes and the appropriate materials to be sprayed.

- 0.011 - 0.013 Lacquers and Stains
- 0.015 - 0.019 Oil and Latex
- 0.021 - 0.026 Heavy Bodied Latex and Block fillers

Fans widths measuring 8" to 12" are most preferred because they offer more control while spraying and are less likely to plug.



XM-Series Pneumatic Airless Sprayers

WORKING PRINCIPLE

The XM pump is a pneumatic pump to be used in the high pressure painting without air (*Airless*) or for transferring of fluids in case of more stations of usage.

This XM Series pump is constituted of an air motor and a structure called «material pumping group» or simply «pumping group». In the pneumatic motor, compressed air causes the vertical reciprocating movement of the motor piston; this movement is transmitted through a connecting rod to the material pumping piston.

The ratios 45:1, 56:1 and 68:1 mean that the outlet pressure of fluid is 45, 56 and 68 times higher than the pump feed air pressure respectively.

TECHNICAL DATA

	XM-45	XM-56	XM-68
PUMP FEED AIR PRESSURE	43 - 100 psi		
MAXIMUM PRESSURE OF THE PRODUCT	4500 psi	5600 psi	6800 psi
*FEED AIR INLET	3/4"		
MATERIAL ENTRY	1" (M)		
MATERIAL EXIT	1/2" (F)		
MAXIMUM DELIVERY	15 l/min	13 l/min	11 l/min
MOTOR DIAMETER	254 mm		
PISTON STROKE	120 mm		
MAX NO. OF CYCLES PER MINUTE	60		
SEALS	TEFLON/LEATHER		
DIMENSIONS	height	128 cm	
	width	68 cm	
	depth	68 cm	
WEIGHT	85 Kg		
NOISE PRESSURE LEVEL	82.7 dB(A) measured at 1 meter from unit		

*N.B. The pump is supplied with a NITTO air connection.

Parts of the pump in contact with the material

Pumping group: galvanized carbon steel and cast iron or stainless steel AISI 303 and 420B

Sealing balls: stainless steel AISI 420B

Gaskets: teflon or nitrile or delrin or vulkollan



Always observe these instructions carefully when evaluating the product compatibility and in case of disposal of some parts of the pump no more usable, in order to meet the environmental regulations on recycling process.



XM-Series Pneumatic Airless Sprayers

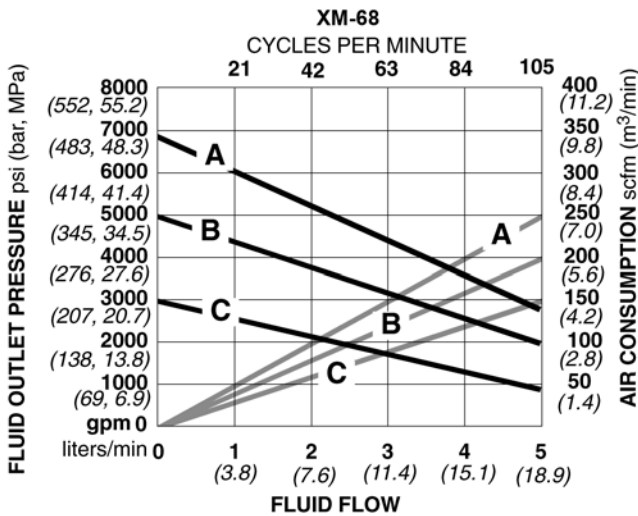
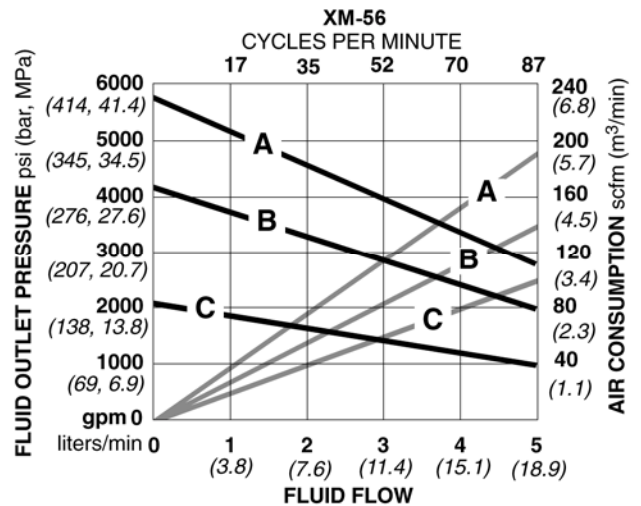
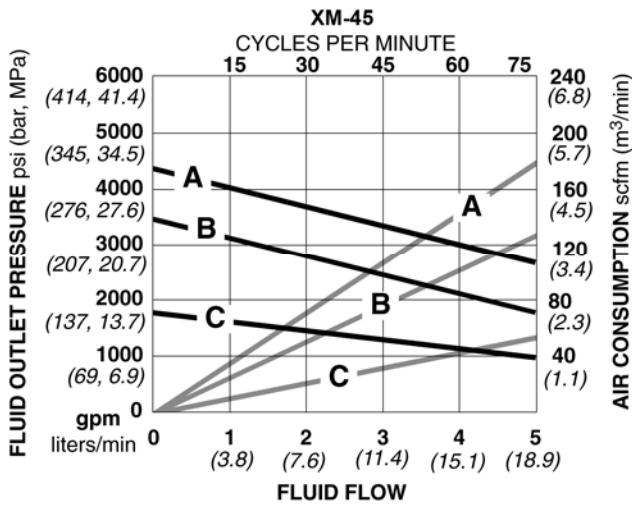
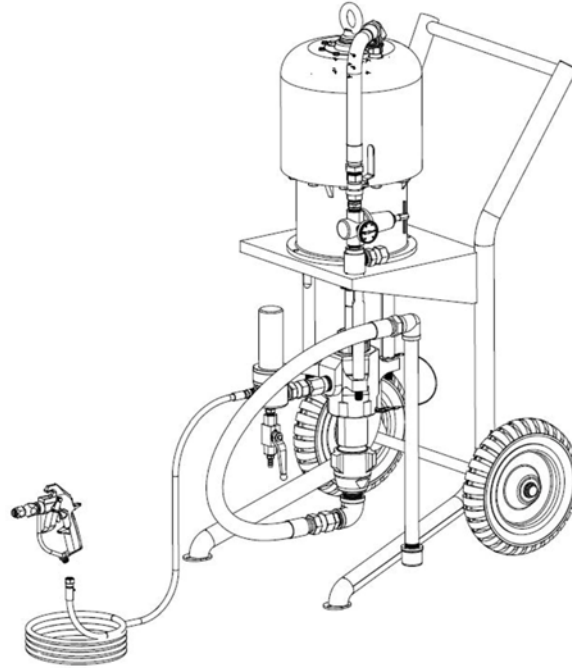

A = 100 PSI
B = 70 PSI
C = 40 PSI

Black curve: Material outlet pressure
Gery curve: Air consumption

The pump can work in continuity when the delivery is limited to the white zone. Out of this zone the speed must be intermittent.

TRANSPORT AND UNPACKING

- The packed parts should be handled as indicated in the symbols and markings on the outside of the packing.
- Before installing the equipment, ensure that the area to be used is large enough for such purposes, is properly lit and has a clean, smooth floor surface.
- The user is responsible for the operations of unloading and handling and should use the maximum care so as not to damage the individual parts or injure anyone. To perform the unloading operation, use only qualified and trained personnel (*truck and crane operators, etc.*) and also suitable hoisting equipment for the weight of the installation or its parts. Follow carefully all the safety rules. The personnel must be equipped with the necessary safety clothing.
- The manufacturer will not be responsible for the unloading operations and transport to the workplace of the machine.
- Check the packing is undamaged on receipt of the equipment. Unpack the machine and verify if there has been any damage due to transportation. In case of damage, call immediately ATOMEX and the Shipping Agent. All the notices about possible damage or anomalies must arrive timely within 8 days at least from the date of receipt of the plant through Registered Letter to the Shipping Agent and to ATOMEX.
- The disposal of packaging materials is a customer's competence and must be performed in accordance with the regulations in force in the country where the plant is installed and used. It is nevertheless sound practice to recycle packaging materials in an environment-friendly manner as much as possible.

SAFETY RULES

- THE EMPLOYER SHALL TRAIN ITS EMPLOYEES ABOUT ALL THOSE RISKS STEMMING FROM ACCIDENTS, ABOUT THE USE OF SAFETY DEVICES FOR THEIR OWN SAFETY AND ABOUT THE GENERAL RULES FOR ACCIDENT PREVENTION IN COMPLIANCE WITH INTERNATIONAL REGULATIONS AND WITH THE LAWS OF THE COUNTRY WHERE THE PLANT IS USED.

THE BEHAVIOUR OF THE EMPLOYEES SHALL STRICTLY COMPLY WITH THE ACCIDENT PREVENTION AND ALSO ENVIRONMENTAL REGULATIONS IN FORCE IN THE COUNTRY WHERE THE PLANT IS INSTALLED AND USED.



Read carefully and entirely the following instructions before using the product. Please save these instructions in a safe place.



The unauthorised tampering/replacement of one or more parts composing the machine, the use of accessories, tools, expendable materials other than those recommended by the Manufacturer can be a danger of accident. The Manufacturer will be relieved from tort and criminal liability.

- KEEP YOUR WORK PLACE CLEAN AND TIDY. DISORDER WHERE YOU ARE WORKING CREATES A POTENTIAL RISK OF ACCIDENTS.
- ALWAYS KEEP PROPER BALANCE AVOIDING UNUSUAL STANCE.
- BEFORE USING THE TOOL, ENSURE THERE ARE NOT DAMAGED PARTS AND THE MACHINE CAN WORK PROPERLY.
- ALWAYS FOLLOW THE INSTRUCTIONS ABOUT SAFETY AND THE REGULATIONS IN FORCE.
- KEEP THOSE WHO ARE NOT RESPONSIBLE FOR THE EQUIPMENT OUT OF THE WORK AREA.
- **NEVER** EXCEED THE MAXIMUM WORKING PRESSURE INDICATED.
- **NEVER** POINT THE SPRAY GUN AT YOURSELVES OR AT OTHER PEOPLE. THE CONTACT WITH THE CASTING CAN CAUSE SERIOUS INJURIES.
- IN CASE OF INJURIES CAUSED BY THE GUN CASTING, SEEK IMMEDIATE MEDICAL ADVICE SPECIFYING THE TYPE OF THE PRODUCT INJECTED. **NEVER** UNDERVALUE A WOUND CAUSED BY THE INJECTION OF A FLUID.
- ALWAYS DISCONNECT THE SUPPLY AND RELEASE THE PRESSURE IN THE CIRCUIT BEFORE PERFORMING ANY CHECK OR PART REPLACEMENT OF THE EQUIPMENT.
- NEVER MODIFY ANY PART IN THE EQUIPMENT. CHECK REGULARLY THE COMPONENTS OF THE SYSTEM. REPLACE THE PARTS DAMAGED OR WORN.
- TIGHTEN AND CHECK ALL THE FITTINGS FOR

CONNECTION BETWEEN PUMP, FLEXIBLE HOSE AND SPRAY GUN BEFORE USING THE EQUIPMENT.

- ALWAYS USE THE FLEXIBLE HOSE SUPPLIED WITH STANDARD KIT. THE USE OF ANY ACCESSORIES OR TOOLING OTHER THAN THOSE RECOMMENDED IN THIS MANUAL, MAY CAUSE DAMAGE OR INJURE THE OPERATOR.
- THE FLUID CONTAINED IN THE FLEXIBLE HOSE CAN BE VERY DANGEROUS. HANDLE THE FLEXIBLE HOSE CAREFULLY. DO NOT PULL THE FLEXIBLE HOSE TO MOVE THE EQUIPMENT. NEVER USE A DAMAGED OR A REPAIRED FLEXIBLE HOSE.



The high speed of travel of the product in the hose can create static electricity through discharges and sparks. It is suggested to earth the equipment.

The pump is earthed through the earth cable of the supply.

The gun is earthed through the high pressure flexible hose. All the conductors near the work area must be earthed.

- NEVER SPRAY OVER FLAMMABLE PRODUCTS OR SOLVENTS IN CLOSED PLACES.
- NEVER USE THE TOOLING IN PRESENCE OF POTENTIALLY EXPLOSIVE GAS.



Always check the product is compatible with the materials composing the equipment (*pump, spray gun, flexible hose and accessories*) with which it can come into contact. Never use paints or solvents containing Halogen

Hydrocarbons (*as the Methylene Chloride*).

If these products come into contact with aluminium parts can provoke dangerous chemical reactions with risk of corrosion and explosion.



Avoid approaching too much to the pump piston rod when the pump is working or under pressure. A sudden movement of the piston rod can cause wounds or finger squashing.



IF THE PRODUCT TO BE USED IS TOXIC, AVOID INHALATION AND CONTACT BY USING PROTECTION GLOVES, GOGGLES AND PROPER FACE SHIELDS.



TAKE PROPER SAFETY MEASURES FOR THE PROTECTION OF HEARING IN CASE OF WORK NEAR THE PLANT.



After a few minutes of operation, the upper metal surface of the machine drops to a very low temperature.

Contact of the skin with the low-temperature area may cause frostbite. Common working clothes and leather gloves provide adequate protection.

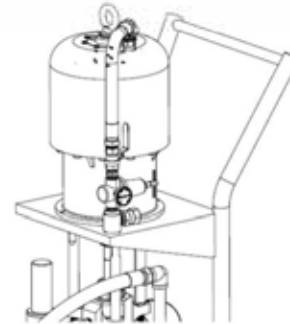

TYPICAL INSTALLATION

The XM pump is generally supplied on support for wall fastening or on trolley. Contact our office for details about wall fastening.

*Int. holes

SETTING-UP

PUMP FASTENING ON THE HOIST

For the correct fastening of the pump on the ram, follow the procedure described in the manual for use and maintenance of the double post ram.

CONNECTION TO THE FEED AIR

For pump feed use a hose with an internal diameter no lower than 20 mm.



Install at the pump inlet an air pressure regulator (it is suggested complete with condensate filter and lubricator). The outlet pressure of the material is 68 times the inlet pressure of the pump feed air. Therefore, it is extremely important to adjust the value of the feed air pressure.

CONNECTION OF THE MATERIAL OUTLET HOSE

Connect the high pressure hose at the outlet of the pump. It is recommended to tighten the fittings.

WORKING



Check all the fittings for connection of the different components (pump, flexible hose, spray gun, etc.) before using the equipment.

- Dip the material pumping hose (H1) into the product tank (H2) (if the pump is fixed on the double post ram, follow the procedure described in the manual of use and maintenance of the double post ram).

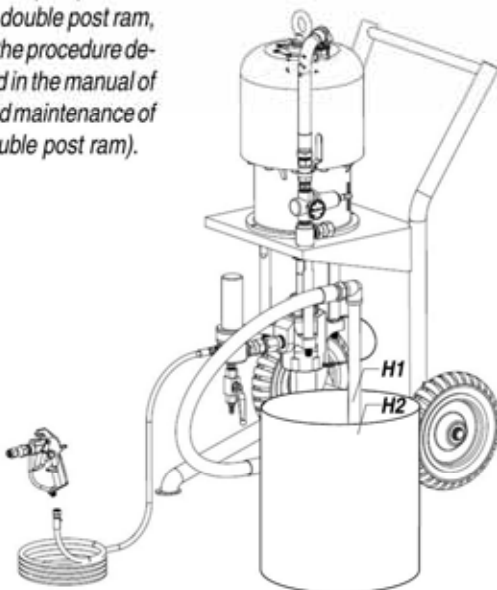

- Make the compressed air flow into the pump. It is advisable to adjust air pressure to minimum necessary for its continuous working.
- When the product chamber is full, pump will start working and stopping. Pump will start working again any time the trigger of the spray gun is pressed or the delivery valve is open.
- The pump has been adjusted at our factory with light mineral oil and a part of it could be left inside the pumping element. Point the spray gun (H3) or the delivery valve at the tank (H4) and drain the product left inside the pump till the material to be used has come out.

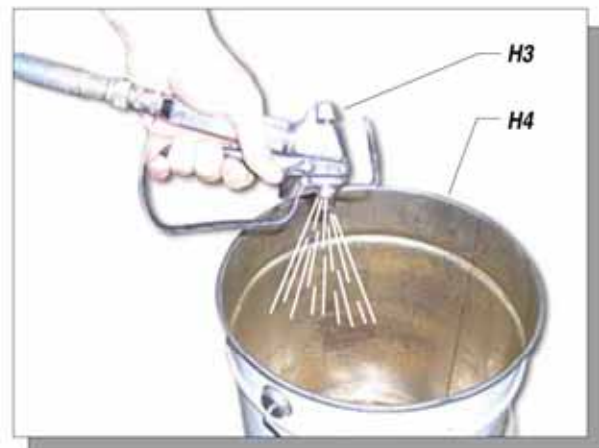

Always avoid pump idling: this operation could damage the pneumatic motor and the seals.

- In case of long inactivity during the use with the plant (for example, all night long at the end of the working day), ensure the product you are using can be left inside the pump and the different pipes without drying. In this case, it is enough to stop the air supply to the pump and drain the residual pressure in the circuit acting on the delivery valve or on the pump bleeder valve.

CLEANING AT THE END OF THE WORK

By "cleaning at the end of the work" is meant the cleaning to carry out in case of use with a different product or if a long period of storage is foreseen.

- Stop the air supply to the pump.
- Dip the material pumping hose into the washing solvent tank (*check its chemical compatibility with the product being used*).
- Make compressed air flow into the pump. It is advisable to adjust the air pressure to minimum necessary to its continuous working.
- Point the spray gun or the delivery valve at a container and drain all the product left inside the pump till a clean solvent comes out.

- Now, stop the air supply to the pump and drain the residual pressure.
- In case of long inactivity, the operations of sucking and leaving light mineral oil inside the pumping element are suggested.



Store possible dangerous fluids in proper containers. Their disposal must be performed in accordance with the regulations in force about the industrial waste goods.

ROUTINE MAINTENANCE



Always close the compressed air supply and release the pressure in the plant before performing any check or maintenance of the pump.

- Check periodically (*and each time the pump is operated after a long storage*) the packing nut is not loosened, causing otherwise the coming out of the product. To tighten the packing nut, lift the wet cup. Use the wrench supply. The packing nut must be tightened so as to avoid wastes of product, but not excessively to provoke pumping piston seizure and seals wear. In case of persistent coming out of product, replace the seals.
- To prevent the product from drying up on the piston rod, refill the cup with lubricant (*compatible with the product used*).
- Check periodically the air supply to the pump. Ensure the air is always clean and lubricated. In case of installation of a lubricator on the air supply to the pump, it is advisable to keep its cup full of a mixture of water and antifreeze liquid (*dilution ratio 4:1*).

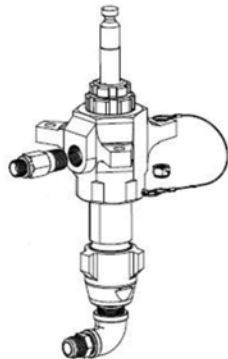

PROBLEMS AND SOLUTIONS

Problem	Cause	Solution
<ul style="list-style-type: none"> The pump does not start 	<ul style="list-style-type: none"> Feed air not sufficient; Outlet product line clogged; Dried product inside the pumping element; Pneumatic motor blocked in the cycle reversal position; Parts failure of the pneumatic motor; 	<ul style="list-style-type: none"> Check the air supply. Widen the diameter of the feed hose; Clean. Disconnect the outlet product pipe. Feed pump at minimum pressure and check if the pump starts without the outlet pipe; Disassemble the pumping group and clean; Turn the plug counterclockwise and push downwards the valve body. Use a metal rod and a mallet; Disassemble the motor and check;
<ul style="list-style-type: none"> Accelerated working and no pressure of the pump 	<ul style="list-style-type: none"> There is no product; The pump sucks air; Feed air not sufficient; Suction valve worn or partially clogged; Outlet valve worn or partially clogged; Suction valve worn or partially clogged; 	<ul style="list-style-type: none"> Add product; Open the bleeder valve. For ram version, follow the instructions in the relevant manual; Increase the feed air pressure; Disassemble the suction valve. Clean and/or replace if necessary the worn parts; Disassemble the outlet valve. Clean and/or replace if necessary the worn parts; Disassemble the suction valve. Clean and/or replace the worn parts;
<ul style="list-style-type: none"> The pump works, but not sufficient flow of product 	<ul style="list-style-type: none"> Outlet product line clogged; The feed air pressure is too low; 	<ul style="list-style-type: none"> Clean. Disconnect the outlet product pipe. Feed pump at minimum pressure and check if delivery increases without the outlet pipe; Increase air pressure;
<ul style="list-style-type: none"> Leakage of product from the wet cup 	<ul style="list-style-type: none"> Upper gaskets worn. 	<ul style="list-style-type: none"> Tighten the packing nut. In case of persistent waste of product, replace the upper gaskets of the pumping element.



Always close the compressed air supply and release the pressure in the plant before performing any check or replacement of parts of the pump.

DESCRIPTION FOR EXPLOSIVE AREAS

These safety instructions refer to the installation, use and maintenance procedures for XM series ATOMEX pneumatic piston pumps for decanting. These pumps are designed for use in potentially explosive areas where gas or vapours are present.



These instructions must be followed in addition to the warnings given in the user and maintenance manual.



XM-Series Pneumatic Airless Sprayers

PART DRAWING

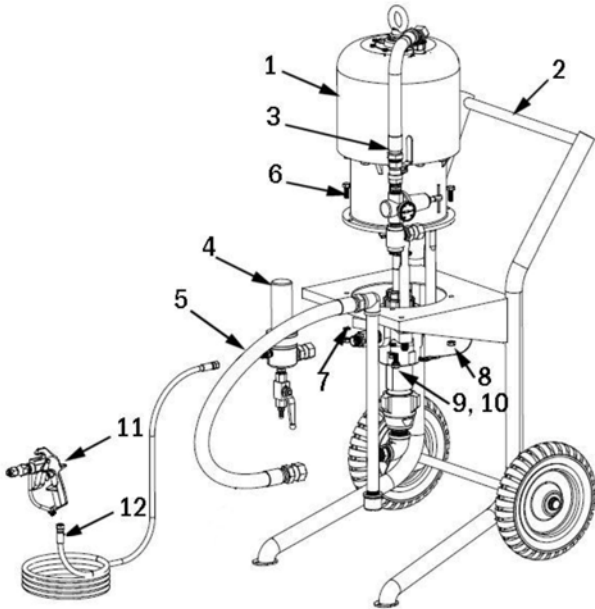

No.	Part	Description	Quantity
1	AX/XM-XXX-101	XM-Series Pump/Air Motor Complete	1
2	AX/XM-254-400	XM-Series Cart	1
3	AX/XM-254-600	XM-Series Air Regulator	1
4	AX/XM-254-104	XM-Series Fluid Filter	1
5	AX/XM-254-700	XM-Series Suction Hose Ass'y	1
6	AX/XM-254-106	XM-Series Bolt	4
7	AX/XM-254-107	XM-Series Washer	4
8	AX/XM-254-108	XM-Series Nut	4
9	AX/XM-254-109	XM-Series Bolt	1
10	AX/XM-254-110	XM-Series Washer	1
11	AX/02-750-000	X-750 Airless Gun w/Tip 7/8" G	1
12	AX/05-400-156	15m Airless Paint Hose 3/8" 7250psi	1

AX/XM-254-200 PARTS

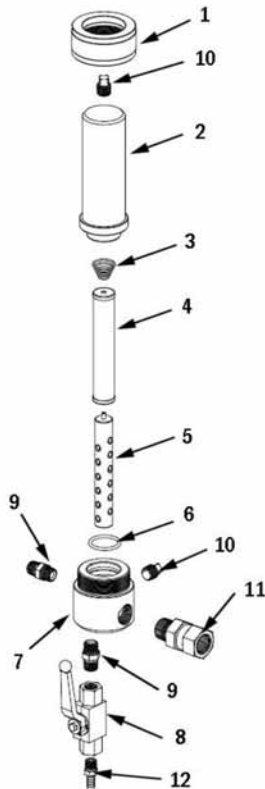

No.	Part	Description	Quantity
1	AX/XM-254-201	XM-Series Filter Ring	1
2	AX/XM-254-202	XM-Series Filter Bowl	1
3	AX/XM-254-203	XM-Series Filter Bowl	1
4	AX/G167-024	Filter Element 30 Mesh	1
	AX/G167-025	Filter Element 60 Mesh (Standard)	1
	AX/G167-026	Filter Element 100 Mesh	1
	AX/G167-027	Filter Element 200 Mesh	1
5	AX/XM-254-205	XM-Series Filter Support	1
6	AX/XM-254-206	XM-Series Filter Packing O-Ring	1
7	AX/XM-254-207	XM-Series Filter Manifold	1
8	AX/XM-254-208	XM-Series Filter Ball Valve	1
9	AX/XM-254-209	XM-Series Filter Nipple	2
10	AX/XM-254-210	XM-Series Filter Plug	2
11	AX/XM-254-211	XM-Series Filter Union	1
12	AX/XM-254-212	XM-Series Filter Hose Tail	1
	AX/XM-254-200	XM-Series Filter Complete	



XM-Series Pneumatic Airless Sprayers

AX/XM-XXX101 PUMP

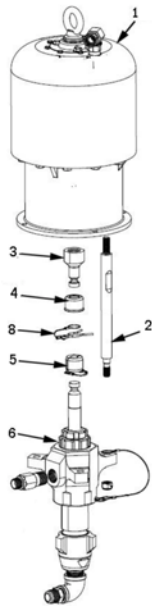

No.	Part	Description	Quantity
1	AX/XM-254-000	XM-Series Air Motor Complete	1
2	AX/XM-254-302	XM-Series Rod, Tie	3
3	AX/XM-254-303	XM-Series Adaptor	1
4	AX/XM-254-304	XM-Series Cover	1
5	AX/XM-254-305	XM-Series Coupling Assembly	1
6	AX/XM-451-100	XM-45 Displacement Pump Ass'Y	1
	AX/XM-561-100	XM-56 Displacement Pump Ass'Y	1
	AX/XM-681-100	XM-68 Displacement Pump Ass'Y	1
7	AX/XM-254-307	XM-Series Nut	3
8	AX/XM-254-308	XM-Series Clip	1

AX/XM-254-400 CART

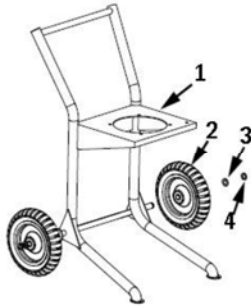

No.	Part	Description	Quantity
1	AX/XM-254-400	XM-Series Cart	1
2	AX/XM-254-402	XM-Series Cart Tyre	2
3	AX/XM-254-403	XM-Series Cart Washer	2
4	AX/XM-254-404	XM-Series Cart Snap Ring	2

AX/XM-254-600 REGULATOR

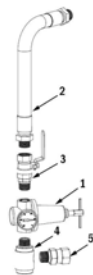

No.	Part	Description	Quantity
1	AX/XM-254-600	XM-Series Regulator, Air Complete	1
2	AX/XM-254-602	XM-Series Regulator Air Hose	1
3	AX/XM-254-603	XM-Series Regulator Shut/Off Valve	1
4	AX/XM-254-604	XM-Series Regulator Air Manifold	1
5	AX/XM-254-605	XM-Series Regulator Coupling	1

AX/XM-254-700 SUCTION HOSE

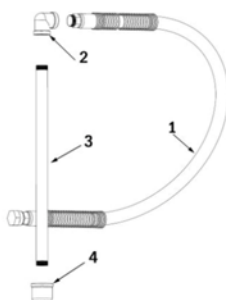

No.	Part	Description	Quantity
1	AX/XM-254-701	XM-Series Suction Hose Only W/Fittings	1
2	AX/XM-254-702	XM-Series Suction Hose Elbow	1
3	AX/XM-254-703	XM-Series Suction Hose Suction Tube	1
4	AX/G181-072	1" Suction Filter S/S	1
0	AX/XM-254-700	XM-Series Suction Hose Ass'y	



XM-Series Pneumatic Airless Sprayers

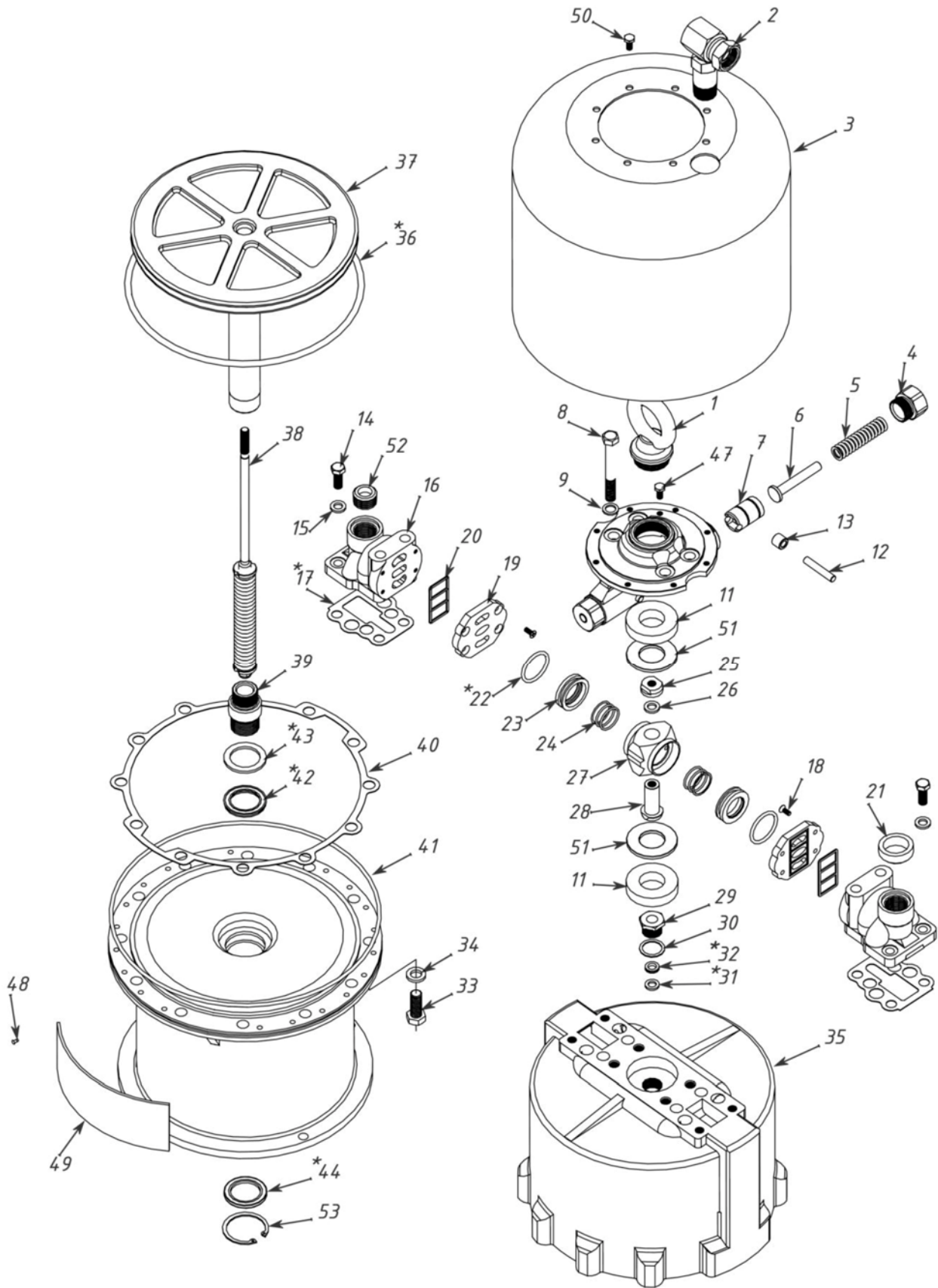



XM-Series Pneumatic Airless Sprayers

PARTS

No.	Part	Description	Quantity	No.	Part	Description	Quantity
1	AX/XM-254-001	XM-Series A/M Ring	1	28	AX/XM-254-028	XM-Series A/M Hub	1
2	AX/XM-254-002	XM-Series A/M Union Adaptor	1	29	AX/XM-254-029	XM-Series A/M Bearing,Trip Rod	1
3	AX/XM-254-003	XM-Series A/M Shield	1	30	AX/XM-254-030	XM-Series A/M Gasket	1
4	AX/XM-254-004	XM-Series A/M Retainer	2	31	AX/XM-254-031	XM-Series A/M Washer,Backup	1
5	AX/XM-254-005	XM-Series A/M Spring,Compression	2	32	AX/XM-254-032	XM-Series A/M V-Packing	1
6	AX/XM-254-006	XM-Series A/M Guide, Spring	2	33	AX/XM-254-033	XM-Series A/M Hex Screw	12
7	AX/XM-254-007	XM-Series A/M Plunger, Detent	2	34	AX/XM-254-034	XM-Series A/M Washer	12
8	AX/XM-254-008	XM-Series A/M Screw	4	35	AX/XM-254-035	XM-Series A/M Cylinder,Air Motor	1
9	AX/XM-254-009	XM-Series A/M Lock Washer	4	36	AX/XM-254-036	XM-Series A/M Seal(O-Ring),Piston	1
10	AX/XM-254-010	XM-Series A/M Housing, Detent	1	37	AX/XM-254-037	XM-Series A/M Piston Ass'Y	1
11	AX/XM-254-011	XM-Series A/M Pad Rubber	2	38	AX/XM-254-038	XM-Series A/M Trip Rod Ass'Y	1
12	AX/XM-254-012	XM-Series A/M Axle	2	39	AX/XM-254-039	XM-Series A/M Stud	1
13	AX/XM-254-013	XM-Series A/M Roller	2	40	AX/XM-254-040	XM-Series A/M Gasket	1
14	AX/XM-254-014	XM-Series A/M Screw	4	41	AX/XM-254-041	XM-Series A/M O-Ring	1
15	AX/XM-254-015	XM-Series A/M Lock Washer	4	42	AX/XM-254-042	XM-Series A/M V-Packing	1
16	AX/XM-254-016	XM-Series A/M Manifold	2	43	AX/XM-254-043	XM-Series A/M Backup Washer	1
17	AX/XM-254-017	XM-Series A/M Gasket,Manifold	2	44	AX/XM-254-044	XM-Series A/M Wiper Seal	1
18	AX/XM-254-018	XM-Series A/M Screw	8	45	AX/XM-254-045	XM-Series A/M Base	1
19	AX/XM-254-019	XM-Series A/M Plate, Valve	2	47	AX/XM-254-047	XM-Series A/M Screw	1
20	AX/XM-254-020	XM-Series A/M Seal,Plate	2	48	AX/XM-254-048	XM-Series A/M Screw	8
21	AX/XM-254-021	XM-Series A/M Grommet	1	49	AX/XM-254-049	XM-Series A/M Name Plate	2
22	AX/XM-254-022	XM-Series A/M Seal(O-Ring)	2	50	AX/XM-254-050	XM-Series A/M Screw	8
23	AX/XM-254-023	XM-Series A/M Valve	2	51	AX/XM-254-051	XM-Series A/M Thrust Washer	2
24	AX/XM-254-024	XM-Series A/M Spring,Compression	2	52	AX/XM-254-052	XM-Series A/M Plug	1
25	AX/XM-254-025	XM-Series A/M Nut, Trip Rod	2		AX/XM-254-500	XM-45/56/68 Air Motor Repair Kit	
26	AX/XM-254-026	XM-Series A/M Lock Washer	1			Includes Items 17,22,30,31,32,36,42,43	
27	AX/XM-254-027	XM-Series A/M Valve Housing	1				



XM-Series Pneumatic Airless Sprayers

AX/XM-451-100 PUMP

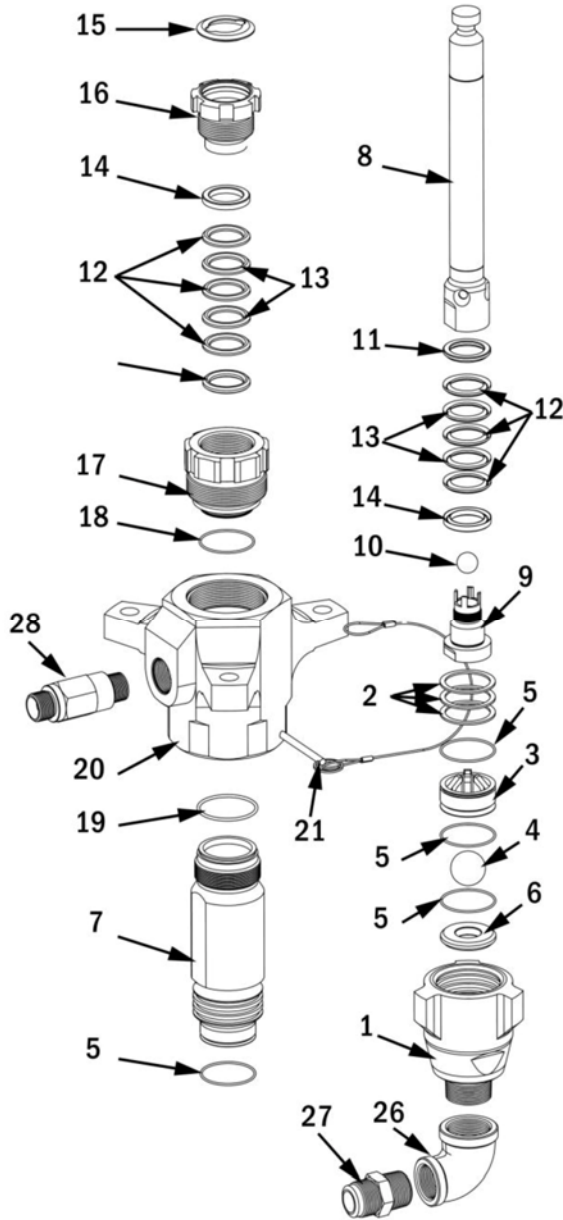

No.	Part	Description	Quantity
1	AX/XM-451-001	XM-45 Housing Inlet	1
2	AX/XM-451-002	XM-45 Shim	3
3	AX/XM-451-003	XM-45 Ball Guide	1
4	AX/XM-451-004	XM-45 Bal 1-1/2"	1
5	AX/XM-451-005	XM-45 Packing,O-Ring	4
6	AX/XM-451-006	XM-45 Seat,Carbide	1
7	AX/XM-451-007	XM-45 Cylinder	1
8	AX/XM-451-008	XM-45 Displacement Rod	1
9	AX/XM-451-009	XM-45 Piston Valve	1
10	AX/XM-451-010	XM-45 Ball 7/8"	1
11	AX/XM-451-011	XM-45 Gland(M)	2
12	AX/XM-451-012	XM-45 Packing(Uhmwpe)	6
13	AX/XM-451-013	XM-45 Packing(Leather)	4
14	AX/XM-451-014	XM-45 Gland(F)	2
15	AX/XM-451-015	XM-45 Plug,Throat Seal	
16	AX/XM-451-016	XM-45 Packing Nut	1
17	AX/XM-451-017	XM-45 Cartridge	1
18	AX/XM-451-018	XM-45 Packing,O-Ring	1
19	AX/XM-451-019	XM-45 Packing,O-Ring	1
20	AX/XM-451-020	XM-45 Housing	1
21	AX/XM-451-021	XM-45 Pin,Self Locking	1
26	AX/XM-451-026	XM-45 Tube,Elbow	1
27	AX/XM-451-027	XM-45 Nipple,Mfm1" -1-1/4"	1
28	AX/XM-451-028	XM-45 Joint Nipple	1
	AX/XM-451-500	XM-45 Repair Kit Fluid	
		Includes Items:	
		4,5,10,11,12,13,14,15,18,19	



XM-Series Pneumatic Airless Sprayers

AX/XM-561-100 PUMP

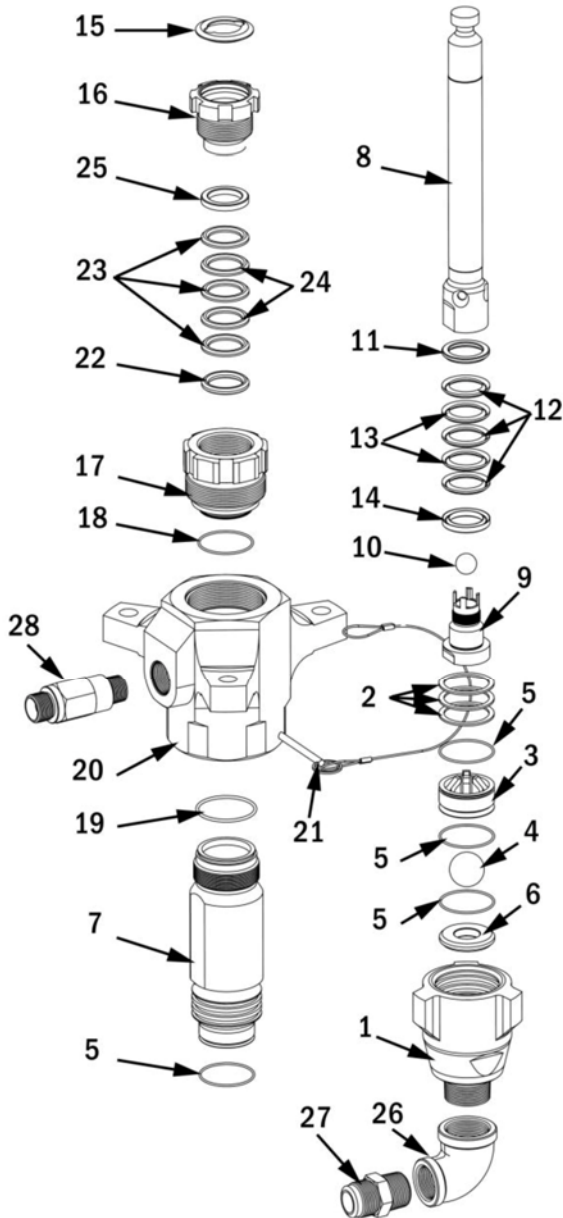

No.	Part	Description	Quantity
1	AX/XM-561-001	XM-56 Housing Inlet	1
2	AX/XM-561-002	XM-56 Shim, Inlet	3
3	AX/XM-561-003	XM-56 Ball Guide	1
4	AX/XM-561-004	XM-56 Ball 1-1/2"	1
5	AX/XM-561-005	XM-56 Packing, O-Ring	4
6	AX/XM-561-006	XM-56 Seat, Carbide	1
7	AX/XM-561-007	XM-56 Cylinder	1
8	AX/XM-561-008	XM-56 Displacement Rod	1
9	AX/XM-561-009	XM-56 Piston Valve	1
10	AX/XM-561-010	XM-56 Ball 7/8"	1
11	AX/XM-561-011	XM-56 Gland(M) (S)	1
12	AX/XM-561-012	XM-56 Packing (Uhmwpe) (S)	3
13	AX/XM-561-013	XM-56 Packing (Leather) (S)	2
14	AX/XM-561-014	XM-56 Gland (F) (S)	1
15	AX/XM-561-015	XM-56 Plug, Throat Seal	1
16	AX/XM-561-016	XM-56 Packing Nut	1
17	AX/XM-561-017	XM-56 Cartridge Throat	1
18	AX/XM-561-018	XM-56 Packing, O-Ring	1
19	AX/XM-561-019	XM-56 Packing, O-Ring	1
20	AX/XM-561-020	XM-56 Housing	1
21	AX/XM-561-021	XM-56 Pin, Self Locking	1
22	AX/XM-561-022	XM-56 Gland (M) (L)	1
23	AX/XM-561-023	XM-56 Packing(Pe) (L)	3
24	AX/XM-561-024	XM-56 Packing(Leather) (L)	2
25	AX/XM-561-025	XM-56 Gland(F) (L)	1
26	AX/XM-561-026	XM-56 Tube, Elbow	1
27	AX/XM-561-027	XM-56 Nipple, Mfm 1" -1-1/4"	1
28	AX/XM-561-028	XM-56 Joint Nipple	1
	AX/XM-561-500	XM-56 Repair Kit Fluid	
		Includes Items: 4,5,10,11,12,13,14,15,18,19,22,23,24,25	



XM-Series Pneumatic Airless Sprayers

AX/XM-681-100 PUMP

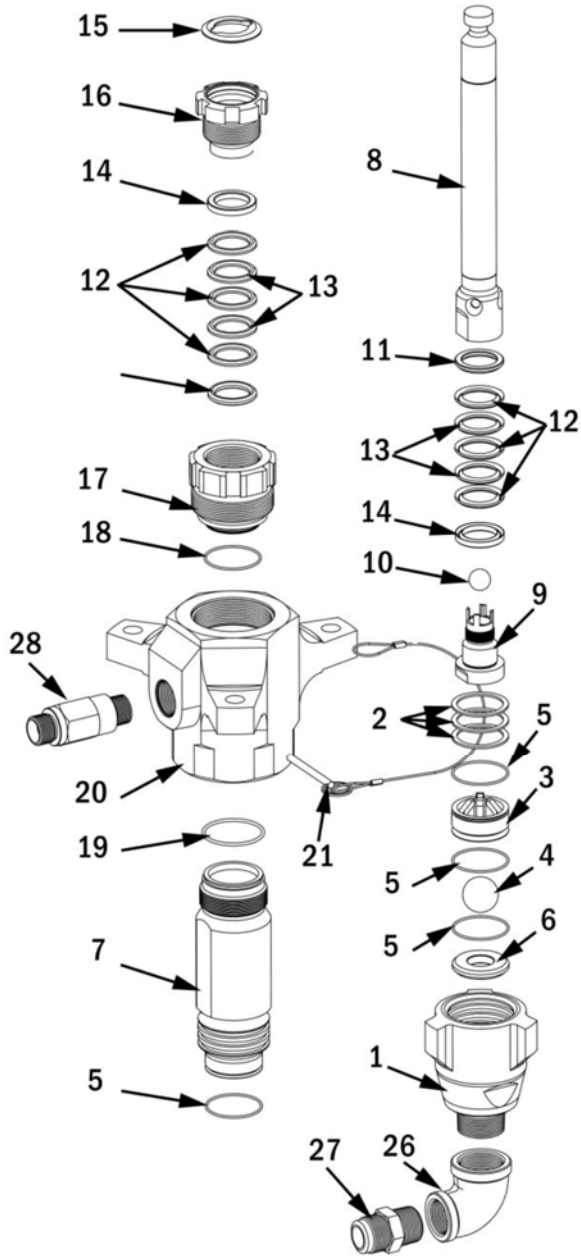

No.	Part	Description	Quantity
1	AX/XM-681-001	XM-68 Housing Inlet	1
2	AX/XM-681-002	XM-68 Shim	3
3	AX/XM-681-003	XM-68 Ball Guide	1
4	AX/XM-681-004	XM-68 Ball (1-1/4")	1
5	AX/XM-681-005	XM-68 Packing O-Ring	4
6	AX/XM-681-006	XM-68 Seat	1
7	AX/XM-681-007	XM-68 Cylinder	1
8	AX/XM-681-008	XM-68 Displacement Rod	1
9	AX/XM-681-009	XM-68 Piston Valve	1
10	AX/XM-681-010	XM-68 Ball (3/4")	1
11	AX/XM-681-011	XM-68 Gland (M)	2
12	AX/XM-681-012	XM-68 Packing (Uhmwpe)	2
13	AX/XM-681-013	XM-68 Packing (Leather)	4
14	AX/XM-681-014	XM-68 Gland (F)	2
15	AX/XM-681-015	XM-68 Seal, Plug	1
16	AX/XM-681-016	XM-68 Packing Nut	1
17	AX/XM-681-017	XM-68 Cartridge, Throat	1
18	AX/XM-681-018	XM-68 Packing, O-Ring	1
19	AX/XM-681-019	XM-68 Packing, O-Ring	1
20	AX/XM-681-020	XM-68 Housing, Outlet	1
21	AX/XM-681-021	XM-68 Pin	1
26	AX/XM-681-026	XM-68 Tube	1
27	AX/XM-681-027	XM-68 Nipple	1
28	AX/XM-681-028	XM-68 Joint Nipple	1
	AX/XM-681-500	XM-68 Repair Kit Fluid	
		Includes Items:	
		4,5,10,11,12,13,14,15,18,19	



XM-Series Pneumatic Airless Sprayers

X-750 Spray Gun

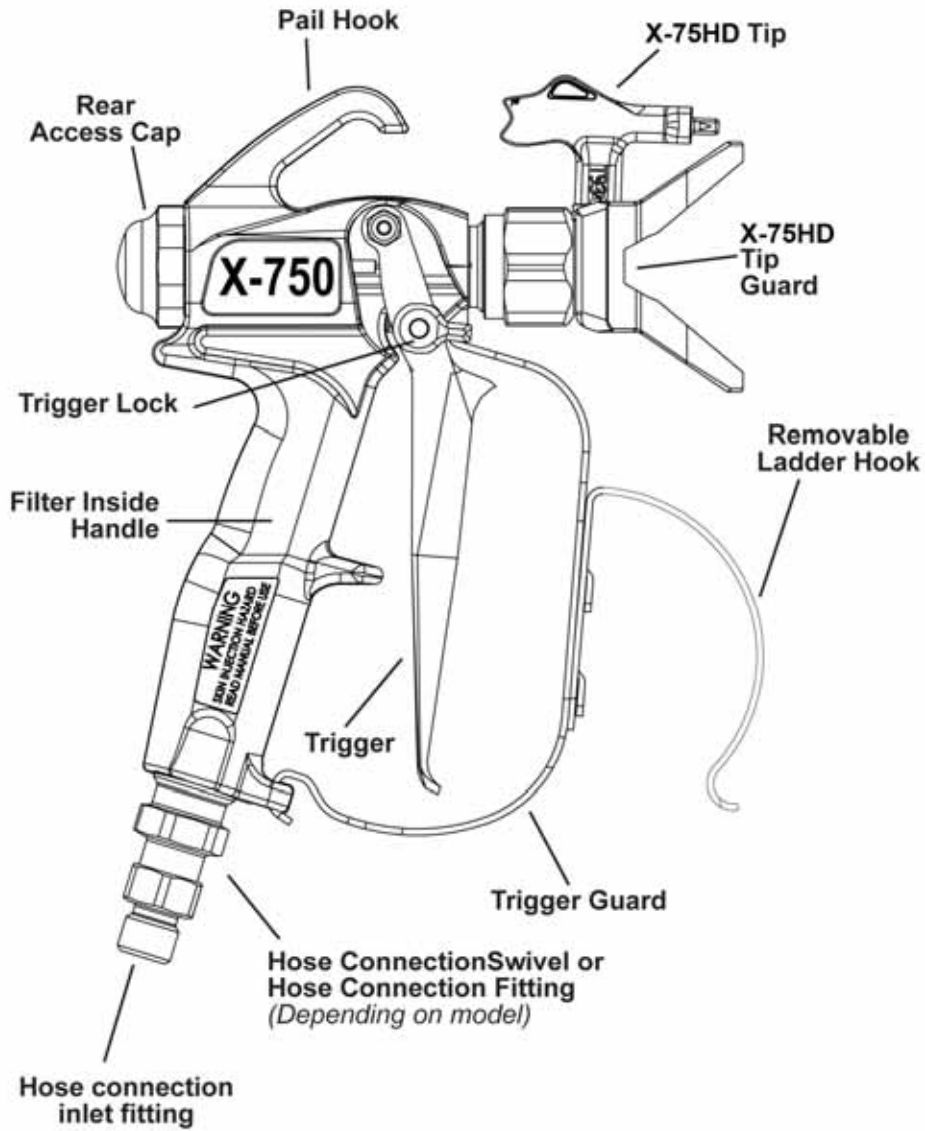

Part No. AX/02-750-000 shown in illustration above.



X-750 Spray Gun Breakdown

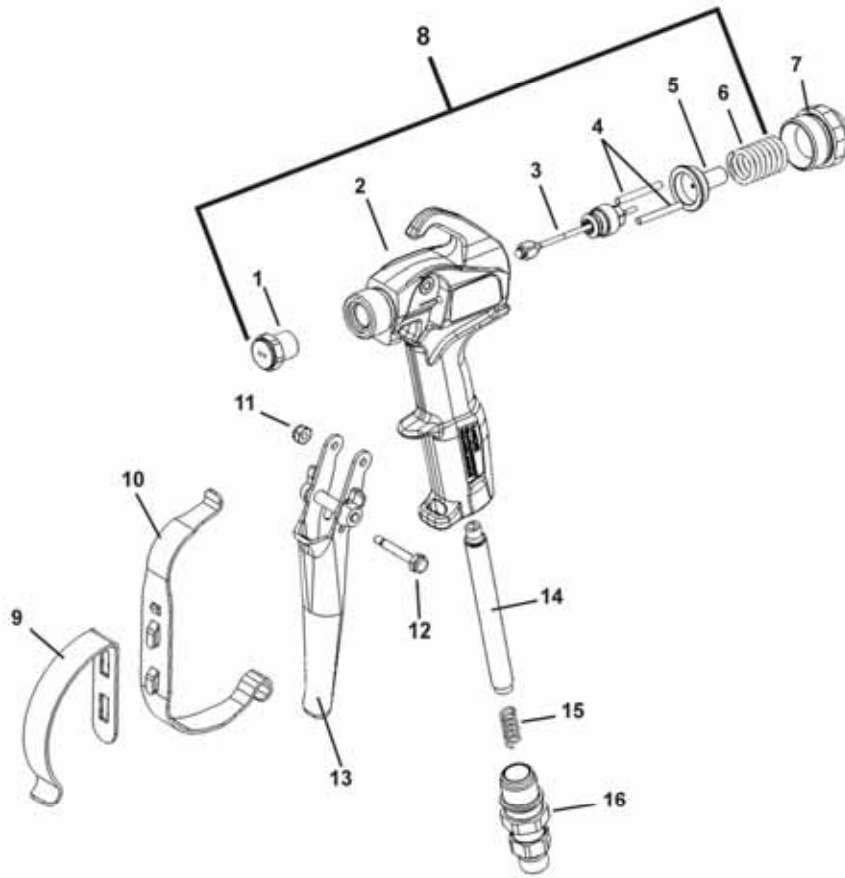

Parts List:				
Item	Part#	Description	Quantity	
1		Diffuser	1	
2	AX/02-750-501	Handle - 7/8"	1	
2	AX/02-750-502	Handle - 11/16"	1	
3		Stem / Seal Assembly	1	
4		Trigger Pin	2	
5		Knob, Retractor	1	
6		Spring, Retractor	1	
7	AX/02-750-503	Cap	1	
8	AX/02-750-500	KIT, Repair - 7/8" and 11/16"		
9	AX/02-750-504	Hook	1	
10	AX/01-400-000	Guard, Trigger	1	
11	AX/02-750-505	Nut, Trigger	1	
12	AX/02-750-506	Shaft, Trigger	1	
13	AX/02-360-507	Trigger, 4-Finger	1	
13	AX/02-360-508	Trigger, 2-Finger	1	
14	AX/W0034377	Filter, 50 Mesh	1	
15	AX/02-360-510	Spring, Filter	1	
16	AX/02-750-509	Swivel, Hose Connection	1	



Spray Tip and Guard Parts List

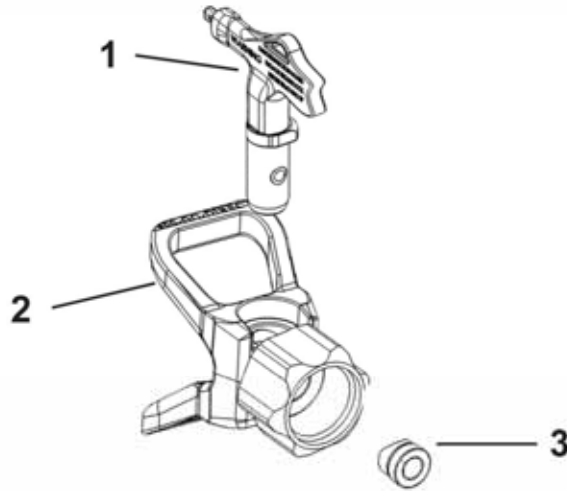

Parts List:			
Item	Part#	Description	Quantity
1	AX/01-200-XXX	X-75M Reversible Tip	1
2	AX/01-400-000	X-75 7500psi Tip Guard 7/8"	1
	AX/01-400-001	X-75 7500psi Tip Guard 11/16"	1
3	AX/01-100-000	X Series Tip + Seal Gasket	1



XM-Series Pneumatic Airless Sprayers



OWNER'S MANUAL

X-750 Professional Airless Spray Gun
For TRAINED, PROFESSIONAL USE ONLY!

Maximum Working Pressure:
7500 PSI - 500 BAR - 50.0 Mpa

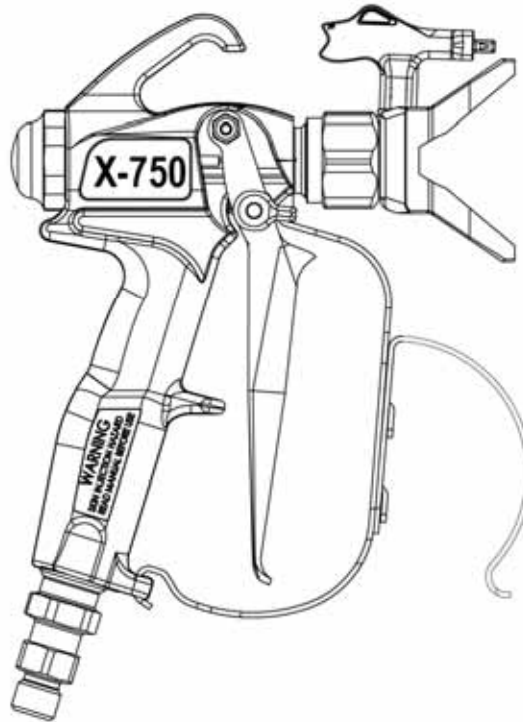

Part No. AX/02-750-000

!! SAFETY and OPERATING INSTRUCTIONS INSIDE !!
Read all warnings and safe operating information inside
SAVE THIS MANUAL FOR FUTURE REFERENCE



XM-Series Pneumatic Airless Sprayers

⚠ WARNING
Keep clear of nozzle

"Do not exceed maximum working pressure."

Safety Precautions

WARNING

HAZARD: Injection injury - A high pressure stream produced by this equipment can pierce the skin and underlying tissues, leading to a serious injury and possible amputation.
 See a physician immediately.

DO NOT TREAT AN INJECTION INJURY AS A SIMPLE CUT!
Injection can lead to amputation. See a physician immediately.

The maximum operating range of the gun is 7500 PSI / 5000 bar fluid pressure.

PREVENTION:

- **NEVER** aim the gun at any part of the body.
- **NEVER** allow any part of the body to touch the fluid stream. **DO NOT** allow body to touch a leak in the fluid hose.
- **NEVER** put hand in front of the gun. Gloves will not provide protection against an injection injury.
- **ALWAYS** lock the gun trigger, shut the pump off, and release all pressure before servicing, cleaning the tip or guard, changing tip, or leaving unattended. Pressure will not be released by turning off the motor. The PRIME/SPRAY valve must be turned to PRIME to relieve the pressure. Refer to the **PRESSURE RELIEF PROCEDURE** described in the pump manual.
- **ALWAYS** keep the tip guard in place while spraying. The tip guard provides some protection but is mainly a warning device.
- **ALWAYS** remove the spray tip before flushing or cleaning the system.
- The paint hose can develop leaks from wear, kinking and abuse. A leak can inject material into the skin. Inspect the hose before each use.
- **NEVER** use a spray gun without a trigger lock and trigger guard in place and in good working order.
- All accessories must be rated at or above the maximum operating pressure range of the airless sprayer. This includes spray tips, guns, extensions, and hose.

NOTE TO PHYSICIAN:
Injection into the skin is a traumatic injury. It is important to treat the injury as soon as possible. **DO NOT DELAY** treatment to research toxicity. Toxicity is a concern with some coatings injected directly into the blood stream. Consultation with a plastic surgeon or reconstructive hand surgeon may be advisable.

HAZARD: EXPLOSION OR FIRE - Solvent and paint fumes can explode or ignite. Severe injury and/or property damage can occur.

PREVENTION:

- Provide extensive exhaust and fresh air introduction to keep the air within the spray area free from accumulation of flammable vapors.
- Avoid all ignition sources such as static electricity sparks, electrical appliances, flames, pilot lights, hot objects, and sparks from connecting and disconnection power cords or working light switches.
- Do not smoke in spray area.
- Fire extinguisher must be present and in good working order.
- Place pump at least 25 feet (7.6m) away from the spray object in a well ventilated area (add more hose if necessary). Flammable vapors are often heavier than air. Floor area must be extremely well ventilated. The pump may contain arcing parts that emit sparks and can ignite vapors.
- The equipment and objects in and around the spray area must be properly grounded to prevent static sparks.
- Use only conductive or grounded high pressure fluid hose. Gun must be grounded through hose connections.
- Power cords must be connected to a grounded circuit.



XM-Series Pneumatic Airless Sprayers

- Always flush unit into a separate metal container, at low pump pressure, with spray tip removed. Hold gun firmly against side of container to ground container and prevent static sparks.
- Follow the material and solvent manufacturer's warnings and instructions.
- Use extreme caution when using materials with a flashpoint below 70° F (21° C). Flashpoint is the temperature that a fluid can produce enough vapors to ignite.
- Plastic can cause static sparks. Never hang plastic to enclose a spray area. Do not use plastic drop cloths when spraying flammable materials.
- Use lowest possible pressure to flush equipment.

HAZARD: EXPLOSION HAZARD DUE TO INCOMPATIBLE MATERIALS - will cause severe injury or property damage.

PREVENTION:

- Do not use materials containing bleach or chlorine.
- Do not use halogenated hydrocarbon solvents such as bleach, mildewcide, methylene chloride and 1,1,1 - trichloroethane. They are not compatible with aluminum.
- Contact your coating supplier about the compatibility of material with aluminum.

HAZARD: HAZARDOUS VAPORS - Paints, solvents, insecticides, and other materials can be harmful if inhaled or come in contact with the body. Vapors can cause severe nausea, fainting, or poisoning.

PREVENTION:

- Use a respirator or mask if vapors can be inhaled. Read all instructions supplied with the mask to be sure it will provide the necessary protection.
- Wear protective eyewear.
- Wear protective clothing as required by coating manufacturer.

HAZARD: GENERAL - Can cause severe injury or property damage.

PREVENTION:

- Read all instructions and safety precautions before operating equipment.
- Always disconnect the motor from the power supply before working on the equipment.
- Follow all appropriate local, state, and national codes governing ventilation, fire prevention, and operation.
- The United States Government Safety Standards have been adopted under the Occupational Safety and Health Act (OSHA). These standards, particularly part 1926 of the Construction Standards should be consulted.
- Use only manufacturer authorized parts. User assumes all risks and liabilities when using parts that do not meet the minimum specifications and safety devices of the pump manufacturer.
- Before each use, check all hoses for cuts, leaks, abrasion or bulging of cover. Check for damage or movement of couplings. Immediately replace the hose if any of these conditions exist. Never repair a paint hose. Replace it with another grounded high-pressure hose.
- All hoses, swivels, guns, and accessories must be pressure rated at or above the maximum operating pressure range of the airless sprayer.
- Do not spray outdoors on windy days.
- Wear clothing to keep paint off skin and hair.



XM-Series Pneumatic Airless Sprayers

The following are general WARNINGS related to the setup, use, grounding, maintenance and repair of this equipment.

⚠ WARNING

FIRE AND EXPLOSION HAZARD

Flammable fumes, such as solvents and paint fumes, in work area can ignite or explode. To help prevent fire and explosion:

- Use equipment only in well ventilated area.
- Eliminate all ignition sources; such as pilot lights, cigarettes, portable electric lamps, and plastic drop clothes (potential static arc.)
- Keep work area free of debris, including solvent, rags and gasoline.
- Sprayers generate sparks. When flammable liquid is used in or near sprayer or for flushing or cleaning, keep sprayer at least 20 feet (6m) away from explosive vapors.
- Do not plug or unplug power cords or turn lights on or off when flammable fumes are present.
- Ground equipment and conductive objects in work area.
- If there is static sparking or you feel a shock, **stop operating immediately**. Do not use equipment until you identify and correct the problem.
- Keep a fire extinguisher in the work area.

SKIN INJECTION HAZARD

High pressure fluid from spray gun, hose leaks or ruptured components will pierce skin. This may look like just a cut, but it is a serious injury that can cause amputation.

Seek immediate surgical treatment.

- Do not point gun at anyone or any part of the body.
- Do not put your hand over the spray tip.
- Do not stop or deflect leaks with your hand, body, glove or rag.
- Do not spray without tip guard and trigger guard installed.
- Engage trigger lock when not spraying.
- Follow pressure relief procedure for your sprayer when you stop spraying and before cleaning, checking or servicing your equipment.

EQUIPMENT MISUSE HAZARD

Misuse can cause death or serious injury.

- Do not exceed the maximum working pressure or temperature rating of the lowest rated system component. See the technical data in all equipment manuals.
- Use fluids and solvents that are compatible with your equipment wetted parts. See technical data in all equipment manuals. Read fluid and solvent manufacturer's warnings. For complete information about your material, request MSDS from your distributor or retailer.
- Check your equipment daily. Repair or replace worn or damaged parts immediately with genuine TriTech replacement parts only.
- Do not alter or modify equipment.
- Use equipment only for its intended purpose. Call TriTech for more information.
- Route hoses and cables away from traffic areas, sharp edges, moving parts and hot surfaces.
- Do not kink or overbend hoses or use hoses to pull equipment.
- Keep children and animals away from work area.
- Comply with all applicable safety regulations.
- Do not operate equipment when fatigued or under the influence of drugs or alcohol.

PRESSURIZED ALUMINUM PARTS HAZARD

Do not use 1,1,1-trichloroethane, methylene chloride, other halogenated hydrocarbon solvents or fluids containing such solvents in this equipment. Such use could result in a serious chemical reaction, with the possibility of explosion, which could cause death, serious injury and/or substantial property damage.

Les mises en garde suivantes sont des MISES EN GARDE de sécurité relatives à la configuration, l'utilisation, la mise à la terre, la maintenance et la réparation de ce matériel.

▲ MISE EN GARDE

DANGER D'INCENDIE ET D'EXPLOSION

Les vapeurs inflammables, vapeurs de solvants et de peinture par exemple, sur le lieu de travail peuvent s'enflammer ou exploser. Pour prévenir un incendie ou une explosion:

- N'utiliser l'équipement que dans des locaux bien ventilés.
- Supprimer toutes les sources de feu, telles que les veilleuses, cigarettes, lampes électriques portatives et bâches plastiques (risque de décharge d'électricité statique).
- Veiller à débarrasser la zone de travail de tout résidu, comme les solvants, les chiffons et l'essence.
- Les pulvérisateurs produisent des étincelles. En cas d'utilisation de liquide inflammable dans ou près du pulvérisateur ou encore pour rincer ou nettoyer, tenir le pulvérisateur à un minimum de 20 ft (6 m) des vapeurs explosives.
- Ne pas brancher ni débrancher de cordons d'alimentation électrique ni allumer ou éteindre la lumière en présence de vapeurs inflammables.
- Raccorder le matériel et les objets conducteurs se trouvant dans la zone de travail à la terre.
- Si l'on remarque la moindre étincelle d'électricité statique ou si l'on ressent une décharge électrique, arrêter le travail immédiatement. Ne pas utiliser le matériel tant que le problème n'a pas été identifié et résolu.
- La présence d'un extincteur est obligatoire dans la zone de travail.

DANGERS D'INJECTIONS

Le produit s'échappant à haute pression du pistolet, d'une fuite sur le flexible ou d'un composant défectueux risque de transpercer la peau. La blessure peut avoir l'aspect d'une simple coupure, mais il s'agit en fait d'une blessure sérieuse pouvant entraîner une amputation.

Consulter immédiatement un médecin en vue d'une intervention chirurgicale.

- Ne pas pointer le pistolet vers une personne ou une partie quelconque du corps.
- Ne pas mettre la main devant la buse de projection.
- Ne jamais colmater ou dévier les fuites avec la main, le corps, un gant ou un chiffon.
- Ne pas pulvériser sans garde-buse ni sous-garde.
- Verrouiller la gâchette à chaque arrêt de la pulvérisation.
- Suivre la procédure de décompression de ce manuel à chaque interruption de pulvérisation et avant le nettoyage, la vérification ou l'entretien du matériel.

DANGER EN CAS DE MAUVAISE UTILISATION DE L'EQUIPEMENT

Toute mauvaise utilisation du matériel peut provoquer des blessures graves, voire mortelles.

- Ne pas dépasser la pression ou température de service maximum spécifiée de l'élément le plus faible du système. Voir les Caractéristiques techniques de tous les manuels de l'appareil.
- Utiliser des produits et solvants compatibles avec les pièces en contact avec le produit. Voir les Caractéristiques techniques de tous les manuels de l'appareil. Lire les mises en garde du fabricant de produit et de solvant. Pour plus d'informations sur votre produit, demandez la fiche de sécurité produit à votre distributeur ou revendeur de produit.
- Vérifier le matériel quotidiennement. Réparer ou remplacer immédiatement toutes les pièces usées ou endommagées uniquement par des pièces d'origine TriTech.
- Ne pas modifier cet équipement.
- N'utiliser ce matériel que pour l'usage auquel il est destiné. Pour plus de renseignements, appelez votre distributeur TriTech.
- Ecarter les flexibles et câbles électriques des zones de circulation, des bords coupants, des pièces en mouvement et des surfaces chaudes.
- Ne pas plier ni trop cintrer les flexibles ni les utiliser pour tirer l'équipement.
- Tenir les enfants et les animaux à l'écart de la zone de travail.
- Se conformer à toutes les règles de sécurité applicables.
- Ne pas utiliser l'appareil si l'on est fatigué ou sous l'influence de drogue ou d'alcool.

RISQUES DUS AUX PIÈCES EN ALUMINIUM SOUS PRESSION

N'utiliser ni 1,1,1-trichloréthane, ni chlorure de méthylène, ni solvants à base d'hydrocarbures halogénés, ni produits contenant de tels solvants dans un appareil sous pression en aluminium. L'utilisation de ces produits risque de déclencher une violente réaction chimique avec risque d'explosion pouvant provoquer de graves dommages matériels et corporels pouvant entraîner la mort.



XM-Series Pneumatic Airless Sprayers

El siguiente texto contiene ADVERTENCIAS generales acerca de la instalación, uso, conexión a tierra, mantenimiento y reparación de este equipo.

⚠ADVERTENCIA

PELIGRO DE INCENDIO Y EXPLOSIÓN

Vapores inflamables, como por ejemplo, vapores de solventes y pintura en el área de trabajo pueden inflamarse o explotar. Para evitar incendios y explosiones:

- Utilice el equipo únicamente en un área bien ventilada.
- Elimine todas las fuentes de combustión, como por ejemplo, luces piloto, cigarrillos, lámparas eléctricas portátiles y cubiertas de plástico (arcos estáticos potenciales).
- Mantenga limpia el área de trabajo, sin solventes, trapos ni gasolina.
- La pistola genera chispas. Al utilizarse un líquido inflamable en la pistola o cerca de ella o para lavarla o limpiarla, manténgala a una distancia mínima de 6 metros de vapores explosivos.
- No enchufe ni desenchufe cables de alimentación ni encienda o apague las luces al trabajar con vapores inflamables.
- Conecte a tierra el equipo y objetos conductores en el área de trabajo.
- Si hay indicios de formación de electricidad estática o si siente una descarga, deje de trabajar inmediatamente y no utilice el equipo hasta haber identificado y corregido el problema.
- Tenga a mano un extintor de incendios en el área de trabajo.

PELIGRO DE INYECCIÓN

El líquido a alta presión procedente de la pistola, de fugas de la manguera o de componentes rotos puede penetrar la piel. Quizá parezca sólo un corte, pero se trata de una lesión grave, que puede llevar a la amputación de un miembro.

Procure atención médica inmediata.

- No apunte nunca la pistola hacia alguien o alguna parte del cuerpo.
- No coloque la mano sobre la boquilla de la pistola.
- No intente bloquear ni desviar fugas con la mano, el cuerpo, los guantes o con un trapo.
- No pulverice sin tener instalado el portaboquillas y el protector del gatillo.
- Trabe el seguro del gatillo cuando no pulveriza.
- Siga las instrucciones de descompresión al dejar de pulverizar y antes de limpiar, revisar o reparar el equipo.

PELIGRO POR UTILIZACIÓN INCORRECTA DEL EQUIPO

La utilización incorrecta puede provocar lesiones graves o mortales.

- No exceda la presión máxima de trabajo o el régimen de temperatura del componente de menor capacidad del sistema. Consulte la información técnica en todos los manuales del equipo.
- Utilice líquidos y solventes compatibles con las piezas húmedas del equipo. Consulte la información técnica en todos los manuales del equipo y lea las advertencias del fabricante acerca de líquidos y solventes. Para obtener información completa acerca del material en cuestión, solicite del distribuidor o revendedor una Ficha de datos de seguridad.
- Revise el equipo a diario. Repare o cambie de inmediato las piezas gastadas o dañadas, únicamente por piezas de repuesto originales de TriTech.
- No altere ni modifique el equipo.
- Utilice el equipo únicamente para los fines a los que está destinado. Para más información, póngase en contacto con TriTech.
- Aleje mangueras y cables de áreas de tráfico, bordes filosos, piezas en movimiento y superficies calientes.
- No retuerza ni doble las mangueras, ni las utilice para arrastrar el equipo.
- Mantenga niños y animales alejados del área de trabajo.
- Respete las normas de seguridad vigentes.
- No utilice el equipo si está fatigado o bajo la influencia de drogas o alcohol.

PELIGRO DE PIEZAS DE ALUMINIO A PRESIÓN

No utilice en el equipo 1,1,1-tricloroetano, cloruro de metileno y otros solventes o líquidos de hidrocarburos halogenados que contengan dichos solventes. Se trata de sustancias que pueden provocar una reacción química peligrosa con posibilidad de explosión, que podría causar la muerte, lesiones graves o ingentes daños materiales.

Im Folgenden finden Sie allgemeine WARNUNGEN bezüglich der Einrichtung, Verwendung, Erdung, Wartung und Reparatur dieser Anlage.

⚠️ WARNUNG!

BRAND- UND EXPLOSIONSGEFAHR

Entflammare Dämpfe wie Lösungsmittel und Farbdämpfe können sich im Arbeitsbereich entzünden oder explodieren. Um Feuer und Explosionen zu vermeiden:

- Verwenden Sie die Ausrüstung nur in gut belüftetem Bereich.
- Entfernen Sie alle Zündquellen wie Anzeigelampen, Zigaretten, tragbare elektrische Lampen und Einmalbekleidung aus Plastik (möglicher statischer Bogen).
- Halten Sie den Arbeitsbereich frei von Fremdkörpern, einschließlich Lösungsmittel, Lumpen und Benzin.
- Sprühanlagen erzeugen Funken. Werden entflammare Flüssigkeiten in oder in der Nähe der Sprühanlage verwendet oder zur Spülung oder Reinigung, halten Sie die Sprühanlage wenigstens 20 Fuß (6m) entfernt von explosiven Dämpfen.
- Stecken Sie keine Stromkabel ein oder ziehen Sie diese aus der Verbindung oder schalten Sie kein Licht ein oder aus, wenn entflammare Dämpfe vorhanden sind.
- Erdungsausrüstung und leitende Objekte im Arbeitsbereich.
- Kommt es zu statischer Funkenbildung oder Sie erhalten einen elektrischen Schlag, ist der Betrieb umgehend einzustellen. Verwenden Sie die Anlage nicht, bis Sie das Problem identifiziert und behoben haben.
- Halten Sie am Arbeitsbereich einen Feuerlöscher bereit.

GEFAHR DER HAUTVERLETZUNG

Unter hohem Druck stehende Flüssigkeiten aus einer Spritzpistole, Löchern im Schlauch oder brüchigen Komponenten durchdringen die Haut. Dies kann einfach wie ein Schnitt aussehen, dabei handelt es sich jedoch um eine schwere Verletzung, die bis zur Amputation führen kann.

Nehmen Sie umgehend ärztliche Hilfe in Anspruch.

- Halten Sie die Spritzpistole nie auf eine Person oder einen Körperteil gerichtet.
- Legen Sie nicht Ihre Hand auf die Spritzdüse.
- Stoppen oder lenken Sie Lecks nicht mit Ihrer Hand, Ihrem Körper, Handschuh oder Lappen ab.
- Sprühen Sie nicht, ohne dass der Düsenschutz und der Auslöserschutz installiert sind.
- Rasten Sie die Auslösersperre ein, wenn Sie nicht sprühen.
- Befolgen Sie den Druckausgleichablauf für Ihre Sprühanlage, wenn Sie mit dem Sprühen aufhören und bevor Sie mit der Reinigung, Überprüfung oder Wartung ihrer Anlage beginnen.

GEFAHR DURCH FALSCHEN EINSATZ DER AUSTRÜSTUNG

Falsche Verwendung kann zu Tod oder schweren Verletzungen führen.

- Überschreiten Sie nicht den maximalen Arbeitsdruck oder die maximale Temperaturauslegung der am niedrigsten ausgelegten Systemkomponente. Schlagen Sie in den technischen Daten in allen Ausrüstungshandbüchern nach.
- Verwenden Sie Flüssigkeiten und Lösungen, die mit den flüssigkeitsbenetzten Teilen der Ausrüstung kompatibel sind. Schlagen Sie in den technischen Daten in allen Ausrüstungshandbüchern nach. Lesen Sie sich die Warnungen der Hersteller von Flüssigkeiten und Lösungen durch. Für vollständige Informationen zu Ihrem Material fordern Sie die Sicherheitsdatenblätter (MSDS) Ihres Versorgers oder Lieferanten an.
- Überprüfen Sie Ihre Ausrüstung täglich. Reparieren oder ersetzen Sie abgenutzte oder beschädigte Teile umgehend nur durch Original-Ersatzteile von TriTech.
- Ändern oder modifizieren Sie die Anlage nicht.
- Verwenden Sie die Ausrüstung nur für den ausgelegten Zweck. Für weitere Informationen kontaktieren Sie TriTech.
- Verlegen Sie Schläuche und Kabel nicht im Verkehrsbereich, in der Nähe von scharfen Kanten, sich bewegenden Teilen oder heißen Oberflächen.
- Knicken oder überbiegen Sie keine Schläuche und verwenden Sie diese nicht, um an der Ausrüstung zu ziehen.
- Halten Sie Kinder und Tiere entfernt vom Arbeitsbereich.
- Stellen Sie sicher, dass Sie allen anwendbaren Sicherheitsbestimmungen entsprechen.
- Betreiben Sie die Anlage nicht, wenn Sie ermüdet sind oder unter dem Einfluss von Medikamenten, Drogen oder Alkohol stehen.

GEFAHR DURCH UNTER DRUCK STEHENDE ALUMINIUM-TEILE

Verwenden Sie in dieser Anlage nicht 1,1,1-Trichlorethan, Methylenchlorid, andere Halogenkohlenwasserstoff- Lösungen oder Flüssigkeiten, die solche Lösungsmittel enthalten. Eine solche Verwendung könnte zu einer ernsten chemischen Reaktion führen, mit der Möglichkeit einer Explosion, die wiederum zum Tod oder zu schweren Verletzungen oder Schäden an der Einrichtung führen könnte.

Grounding and Electric Requirements Exigences électriques et de mise à la terre Requisitos eléctricos y de conexión a tierra Anforderungen an Erdung und Elektronik



The sprayer and gun must be grounded. Grounding reduces the risk of static and electric shock by providing an escape wire for the electrical current due to static build up or in the event of a short circuit. Follow the grounding instructions included in the equipment manual provided with your sprayer. Additional grounding instructions for this spray gun are included below.

Ce pulvérisateur et son pistolet doivent être raccordés à la terre. La mise à la terre réduit les risques d'électricité statique et de décharge électrique grâce à un fil permettant au courant de s'échapper en cas d'accumulation d'électricité statique ou de court-circuit. Suivre les instructions de mise à la terre incluses dans le manuel de l'équipement fourni avec le pulvérisateur. Des instructions supplémentaires de mise à la terre pour ce pistolet pulvérisateur sont incluses ci-dessous.

El pulverizador y la pistola deben conectarse a tierra. La puesta a tierra reduce el riesgo de choque electrostático o eléctrico, mediante un cable de descarga de la corriente eléctrica originada por la acumulación de electricidad estática o en caso de cortocircuito. Siga las instrucciones de conexión a tierra del manual del equipo que se suministra con el pulverizador. A continuación se ofrecen más instrucciones de conexión a tierra para esta pistola de pulverización.



Die Sprühanlage und die Spritzpistole müssen geerdet sein. Erdung verringert das Risiko eines statischen und elektrischen Schocks, indem dem elektrischen Strom eine Ausgleichsleitung für die statische Aufladung geboten wird oder für den Fall eines Kurzschlusses. Folgen Sie den Erdungsanweisungen, die im Handbuch zur Ausrüstung beinhaltet sind, und das Ihnen mit der Sprühanlage zur Verfügung gestellt wird. Zusätzliche Erdungsanweisungen für die Spritzpistole sind unten eingefügt.

Ground your spray gun through connection to a properly grounded fluid hose and sprayer or pump.

Raccorder le pistolet à la terre via un flexible produit et le pulvérisateur ou la pompe correctement reliés à la terre.

Ponga a tierra la pistola mediante una conexión a una manguera, pulverizador o bomba de líquidos debidamente conectados a tierra.

Erden Sie Ihre Spritzpistole durch Verbindung zu einem entsprechend geerdeten Flüssigkeitsschlauch und Sprühanlage oder Pumpe.

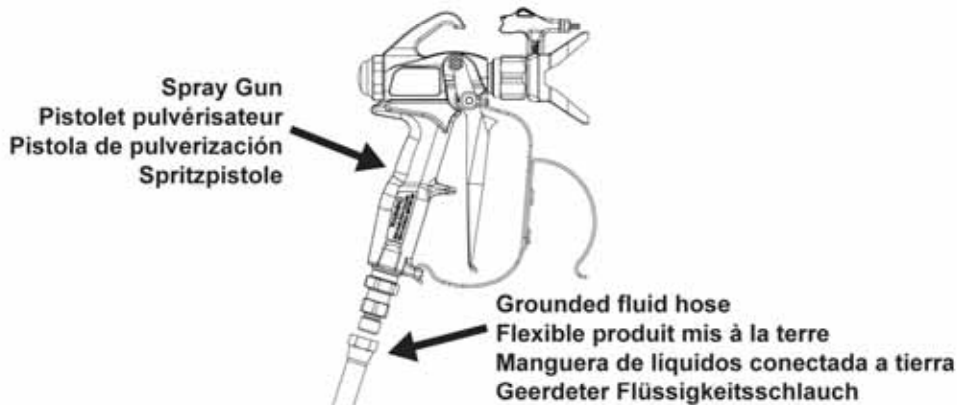

Setup Installation Ajuste Einrichtung

⚠WARNING

Never attempt to assemble, change, or clean the gun, tip, or tip guard without first relieving pressure from the spray system. Follow the "PRESSURE RELIEF PROCEDURE" in the sprayer's equipment manual.

Ne jamais essayer d'assembler, de remplacer ou de nettoyer le pistolet, la buse, le garde-buse avant d'avoir au préalable décompressé le système de pulvérisation. Suivre la PROCEDURE DE DECOMPRESSION du manuel de l'équipement de pulvérisation.

Jamás intente armar, cambiar o limpiar la pistola, la boquilla o el portaboquillas sin descomprimir primero el sistema de pulverización. Siga las instrucciones del PROCEDIMIENTO DE DESCOMPRESIÓN del manual del pulverizador.

Versuchen Sie niemals die Pistole, die Düse oder den Düsenschutz anzupassen, zu ändern oder zu säubern, ohne vorher den Druck aus dem Spritzsystem zu entlassen. Befolgen Sie den "DRUCKAUSGLEICHLAUF" im Handbuch der Ausrüstung zur Sprühanlage.

⚠WARNING

Always use tip safety guard for added protection against injection. Beware that the guard alone will not prevent injection. NEVER cut off tip guard! Always engage gun trigger lock when the gun is not in use. Before servicing equipment, consult all equipment manuals and follow all warnings.

Toujours utiliser le garde-buse de sécurité pour une protection accrue contre les injections. Attention : le garde-buse seul ne peut empêcher les injections. NE JAMAIS couper cette garde-buse ! Toujours verrouiller la gâchette à chaque arrêt de la pulvérisation. Avant de procéder à l'entretien de l'équipement, consulter tous les manuels de l'équipement et respecter toutes les mises en garde.

Utilice siempre el protector de seguridad, para una mayor protección contra el peligro de inyección. Tenga cuidado, puesto que no basta con el protector para evitar la inyección. ¡JAMÁS corte el portaboquillas! Siempre trabe el seguro del gatillo cuando el pulverizador no se usa. Antes de realizar el mantenimiento del equipo, consulte todos los manuales y respete todas las advertencias.

Verwenden Sie immer den Düsensicherheitsschutz für zusätzlichen Schutz gegen Einspritzung. Seien Sie vorsichtig, denn der Schutz alleine schützt nicht vor Einspritzung. Schlagen Sie NIEMALS den Düsenschutz ab! Aktivieren Sie immer die Pistolenauslösersperre, wenn die Pistole nicht verwendet wird. Bevor Sie die Ausrüstung warten, schlagen Sie in den Ausrüstungshandbüchern nach und befolgen alle Warnungen

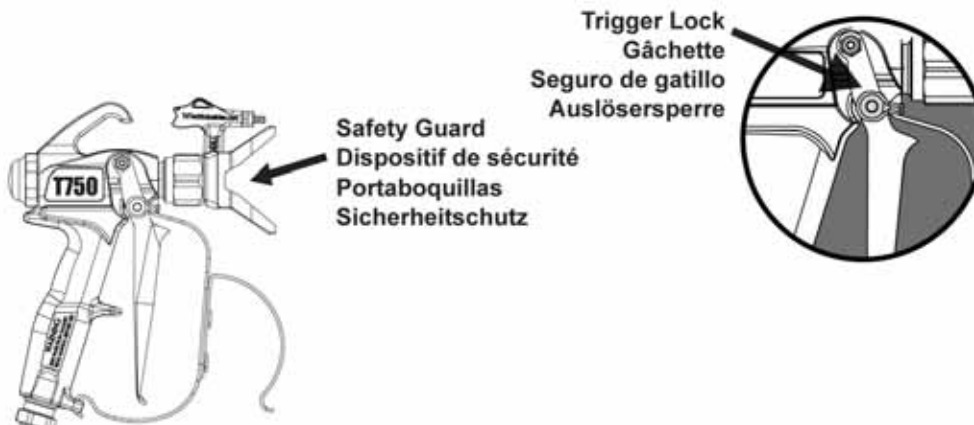



X-750 Professional Airless Spray Gun

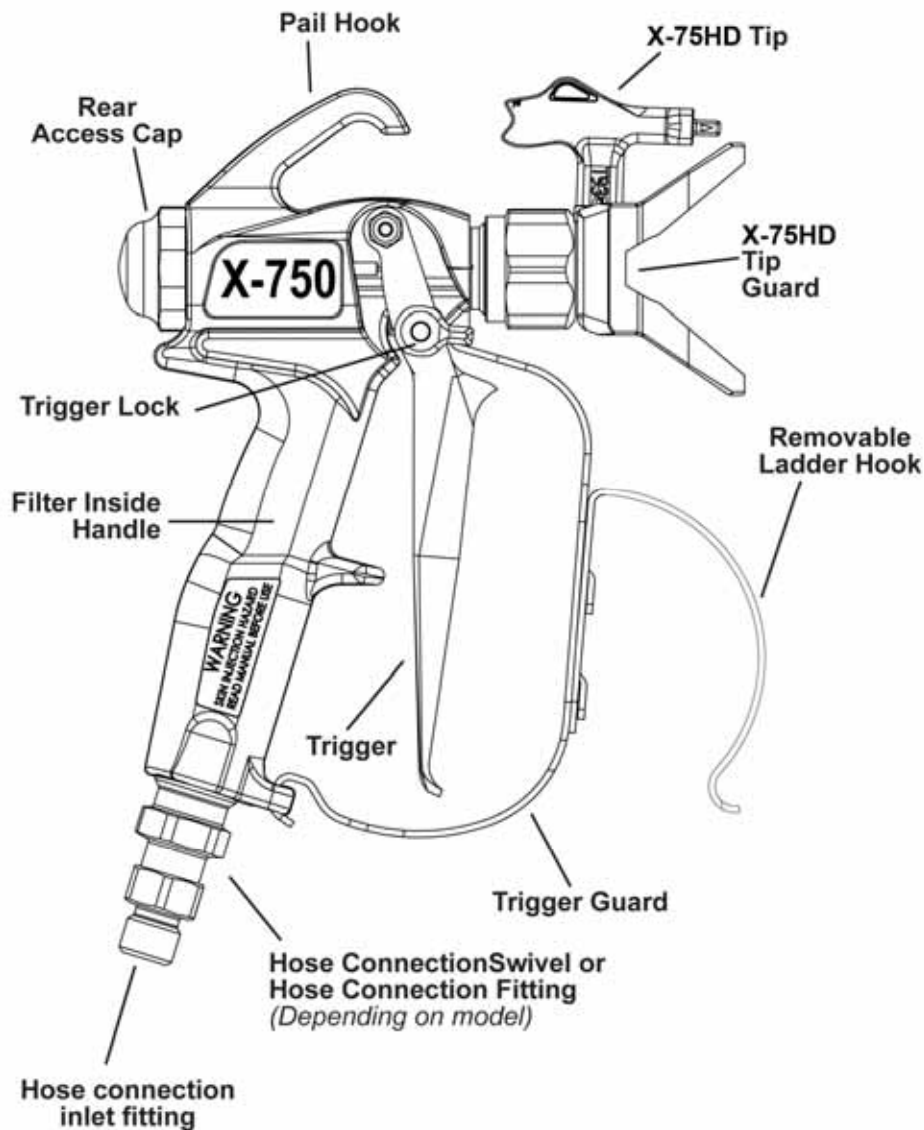

Part No. AX/02-750-000 shown in illustration above.

If the X-750 spray gun model you own came with the tip included, follow the instructions below to install the guard and tip. If you are using a different tip, follow the installation instructions provided with the tip you are using.

Si votre modèle de pistolet pulvérisateur X-750 comporte une buse, suivez les instructions ci-dessous pour installer le garde-buse et la buse. Si vous utilisez une buse différente, suivez les instructions de montage fournies avec la buse que vous utilisez.

Si la pistola de pulverización modelo X-750 que ha comprado vino con la boquilla incluida, siga las instrucciones a continuación para instalar el portaboquillas y la boquilla. Si utiliza otra boquilla, siga las instrucciones de instalación que la acompañan.

Wurde das Spritzpistolenmodell X-750, das Ihnen gehört, mit Düse geliefert, befolgen Sie die Anweisungen unten, um den Schutz und die Düse zu installieren. Verwenden Sie eine andere Düse, befolgen Sie die Installationsanweisungen, die mit der Düse bereitgestellt wurden, die Sie verwenden.

Installation of tip and guard

Montage de la buse et du garde-buse

Instalación de la boquilla y el portaboquillas

Spitze-und Schutz-Installation



A. Use seal alignment tool on X-75HD tip handle to insert seal and pressure gasket into back of guard, turn to align with tip shaft opening.
 B. Insert tip into opening on X-75HD guard. NOTE: Narrow end of tip handle should be in forward position for spraying.
 Thread the guard onto gun head until it stops. Tighten slightly with wrench - DO NOT OVER TIGHTEN.

A. Utiliser l'outil d'alignement du joint sur la poignée de la buse X-75HD pour insérer le joint et le joint statique de pression à l'arrière du garde-buse, tourner pour aligner avec l'ouverture de l'arbre de la buse.
 B. Insérer la buse dans l'ouverture sur le garde-buse X-75HD. REMARQUE : Le collet de la poignée de la buse doit être placé en position avant pour la pulvérisation.
 Faire passer le garde-buse sur la tête du pistolet jusqu'au blocage. Serrer légèrement avec une clé. NE PAS TROP SERRER.

A. Utilice una herramienta de alineación de sello en la empuñadura de la boquilla X-75HD para introducir el sello y la junta de presión en la parte posterior del protector, gire para alinear con la abertura del eje de la boquilla.
 B. Inserte la boquilla en la abertura del protector de X-75HD. OBSERVACIÓN: El extremo angosto de la empuñadura de la boquilla debe estar en posición delantera para pulverizar.
 Inserte el protector en el cabezal de la pistola hasta que se detenga. Apriete levemente mediante una llave apropiada: NO APRIETE DEMASIADO.

A. Verwenden Sie das Dichtungsabgleichwerkzeug beim X-75HD Düsenhalter, um Dichtung und Druckabdichtung auf der Rückseite des Schutzes einzufügen und drehen Sie es um es mit der Achsenöffnung auszurichten.
 B. Fügen Sie die Düse in die Öffnung des X-75HD ein. HINWEIS: Das schmale Ende des Düsenhalters sollte sich in Vorwärtsstellung für Sprühen befinden.
 Bringen Sie den Schutz auf den Pistolenkopf an, bis er stoppt. Leicht mit Schlüssel anziehen - NICHT ZU STARK ANZIEHEN.

Spray Gun Pistolet pulvérisateur Pistola de pulverización Spritzpistole

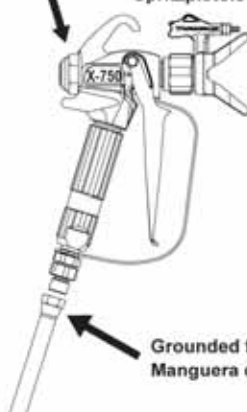

Attach a properly grounded fluid hose to the fluid hose connection fitting on the bottom of the handle of your spray gun. Use two (2) wrenches - one on the gun and one on the hose. Tighten securely.

Raccorder un flexible produit correctement mis à la terre à la fixation du raccord du flexible produit sur le bas de la poignée du pistolet pulvérisateur. Utiliser deux (2) clés : l'une sur le pistolet et l'autre sur le flexible. Bien serrer

Conecte una manguera de líquido debidamente conectada a tierra al dispositivo de conexión de la manguera, en la parte inferior de la empuñadura de la pistola. Utilice dos (2) llaves, una para la pistola y otra en la manguera. Apriete fuerte.

Bringen Sie einen ordentlich geerdeten Flüssigkeitsschlauch an das Flüssigkeitsschlauchverbindungsstück unten am Halter Ihrer Sprühpistole an. Verwenden Sie zwei (2) Schlüssel - einen für die Pistole und einen für den Schlauch. Sicher festziehen.

Grounded fluid hose - Flexible produit mis à la terre
 Manguera de líquidos conectada a tierra - Geerdeter Flüssigkeitsschlauch

Trigger Lock Positions
Position de la gâchette
Posiciones del seguro del gatillo
Stellungen Auslösersperre

Locked
Verrouillée
Bloqueado
Gesperrt



Unlocked
Déverrouillée
Desbloqueado
Entsperrt



Operation
Fonctionnement
Operación
Betrieb

1. Make sure your tip is in the spray position.
2. Start your sprayer following the instructions provided in the equipment owner's manual.
3. Adjust the fluid pressure on the sprayer until proper atomization is achieved. Always spray at the lowest pressure necessary to get the desired atomization.

1. S'assurer que la buse est en position de pulvérisation.
2. Démarrer le pulvérisateur en suivant les instructions fournies dans le manuel d'utilisateur de l'équipement.
3. Ajuster la pression du fluide sur le pulvérisateur jusqu'à obtention d'une pulvérisation appropriée. Toujours pulvériser à la pression inférieure nécessaire pour obtenir la pulvérisation souhaitée.

1. Asegúrese de que la boquilla está en la posición de pulverización.
2. Comience a pulverizar conforme a las instrucciones que se incluyen en el manual del usuario del equipo.
3. Regula la presión del líquido de la pistola hasta alcanzar una adecuada atomización. Siempre trabaje a la mínima presión necesaria para obtener la pulverización deseada.

1. Stellen Sie sicher, dass sich Ihre Düse in der Sprühstellung befindet.
2. Starten Sie Ihre Sprühanlage entsprechend den Anweisungen, die Sie im Handbuch zur Ausrüstung befinden.
3. Passen Sie den Flüssigkeitsdruck in der Sprühanlage an, bis die gewünschte Zerstäubung erreicht ist. Sprühen Sie immer mit dem geringsten notwendigen Druck, um die gewünschte Zerstäubung zu erreichen.

Tip Clogs
Déboucher la buse
Obstrucción de la boquilla
Verstopfungen der Düse

If you are using a ATOMEX X-75HD tip, follow the instructions on the next page to clear a clogged tip. If you are using a different tip, follow the instructions included in the equipment manual provided with that tip.

Si vous utilisez une buse ATOMEX X-75HD, suivez les instructions de la page suivante pour déboucher une buse. Si vous utilisez une buse différente, suivez les instructions incluses dans le manuel de l'équipement fourni avec cette buse.

Si utiliza una boquilla ATOMEX X-75HD, siga las instrucciones de la página siguiente, para desobstruir una boquilla tapada. Si utiliza otra boquilla, siga las instrucciones del manual del equipo que la acompaña.

Verwenden Sie eine ATOMEX X-75HD, befolgen Sie die Anweisungen auf der nächsten Seite um eine verstopfte Düse zu säubern. Verwenden Sie eine andere Düse, befolgen Sie die Anweisungen, die Sie im Ausrüstungshandbuch vorfinden, das Ihnen mit der Düse ausgeliefert wurde.

Tip Clogs

Déboucher la buse

Obstrucción de la boquilla

Verstopfungen der Düse

1. Engage trigger Lock. Rotate tip handle 180° to the reverse position.
 2. Unlock trigger. Point the gun into a bucket holding the gun away from you. Trigger the gun briefly to expel the clog.
 3. Engage trigger Lock. Rotate tip handle 180° to the spray position.
 4. Unlock trigger. Spray a test to be sure the clog is completely expelled.
- NOTE: If clog is not completely expelled after following the above steps, repeat steps 1-4 until the clog is completely cleared.

1. Verrouiller la gâchette. Tourner la poignée de la buse à 180°.
 2. Déverrouiller la gâchette. Pointer le pistolet dans un seau à bonne distance de votre corps. Actionner le pistolet brièvement pour déboucher.
 3. Verrouiller la gâchette. Tourner la poignée de la buse à 180° dans la position de pulvérisation.
 4. Déverrouiller la gâchette. Faire un test de pulvérisation pour s'assurer que le bouchon est totalement expulsé.
- REMARQUE : si le bouchon n'est pas entièrement expulsé après avoir suivi les étapes ci-dessus, répéter les étapes 1-4 jusqu'à déblocage total.

1. Trabe el seguro del gatillo. Gire la empuñadura de la boquilla 180° hasta la posición inversa.
 2. Destrabe el gatillo. Apunte la pistola hacia el interior de un cubo (balde), manteniendo la pistola alejada del cuerpo. Dispare brevemente la pistola para expulsar la obstrucción.
 3. Trabe el seguro del gatillo. Gire la empuñadura de la boquilla 180° hasta la posición de pulverización.
 4. Destrabe el gatillo. Haga una pulverización de prueba para asegurarse de haber eliminado completamente la obstrucción.
- OBSERVACIÓN: Si después de seguir los pasos anteriores la boquilla sigue parcialmente obstruida, repita las etapas 1 a 4 hasta eliminar por completo la obstrucción.

1. Auslösersperre aktivieren. Drehen Sie den Düsenhalter um 180° auf die Gegenposition.
 2. Entsperren Sie den Auslöser. Richten Sie die Pistole in einen Eimer und halten Sie die Pistole von sich selbst weg. Lösen Sie die Pistole leicht aus, um die Verstopfung auszustoßen.
 3. Auslösersperre aktivieren. Drehen Sie den Düsenhalter um 180° auf die Sprühposition.
 4. Entsperren Sie den Auslöser. Führen Sie einen Sprühtest durch, um sicherzustellen, dass die Verstopfung vollständig entfernt wurde.
- HINWEIS: Ist die Verstopfung nach Durchführung obiger Schritte nicht vollständig entfernt, wiederholen Sie die Schritte 1 - 4, bis die Verstopfung vollständig entfernt ist.

Locked
Verrouillé
Bloqueado
Gesperrt



Seal Removal

Démonter le joint

Extracción del sello

Entfernung der Dichtung

Follow the pressure relief procedure as instructed in your equipment owner's manual. Engage trigger lock. Remove guard from gun head. Push seal and gasket out rear of guard using narrow end of tip handle.

Suivre la procédure de décompression comme indiqué dans le manuel d'utilisateur. Verrouiller la gâchette. Démonter la garde de la tête du pistolet. Sortir le joint et le joint statique de l'arrière de la garde en utilisant le collet de la poignée de la buse. Siga el procedimiento de la relevación de presión.

Siga las instrucciones de descompresión que se incluyen en el manual del usuario del equipo. Trabe el seguro del gatillo. Retire el protector del cabezal de la pistola. Extraiga el sello y la junta de la parte posterior del protector utilizando el extremo angosto de la empuñadura de la boquilla.

Befolgen Sie den Druckausgleichablauf wie im Handbuch zur Ausrüstung angegeben. Auslösersperre aktivieren. Schutz vom Pistolenkopf entfernen. Drücken Sie die Dichtung und Abdichtung hinten aus dem Schutz heraus, indem Sie das schmale Ende des Düsenhalters verwenden.

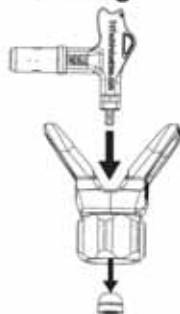

Filter Cleaning and Replacement Nettoyage et remplacement du filtre Limpieza y cambio de filtro Filter säubern und ersetzen

Filter Removal Démonter le filtre Extracción del filtro Filter entfernen



IMPORTANT! YOU MUST RELIEVE ALL FLUID PRESSURE FROM YOUR ENTIRE SPRAY SYSTEM INCLUDING THE SPRAYER, HOSE AND GUN BEFORE DISCONNECTING THE HOSE! Turn off your sprayer and follow the pressure relief procedure as instructed in your equipment owner's manual. Engage trigger lock. Disconnect the hose from the connection at the bottom of your gun.

IMPORTANT ! ENLEVER OBLIGATOIREMENT TOUTE LA PRESSION LIQUIDE DE L'ENSEMBLE DU SYSTEME DE PULVERISATION Y COMPRIS DU PULVERISATEUR, DU FLEXIBLE ET DU PISTOLET AVANT DE DEMONTER LE FLEXIBLE ! Fermer le pulvérisateur et suivre la procédure de décompression comme indiqué dans le manuel d'utilisateur. Verrouiller la gâchette. Désolidariser le flexible du raccord situé en bas du pistolet.

IMPORTANTE: ¡ANTES DE DESCONECTAR LA MANGUERA, ES PRECISO LIBERAR TODA LA PRESIÓN DEL LIQUIDO EN TODO EL SISTEMA DE PULVERIZACIÓN, INCLUIDO EL PULVERIZADOR, LA MANGUERA Y LA PISTOLA! Desactive el pulverizador y siga las instrucciones de descompresión que se incluyen en el manual del usuario del equipo. Trabe el seguro del gatillo. Desconecte la manguera de la conexión en la parte inferior de la pistola.

WICHTIG! SIE MÜSSEN DEN GESAMTEN FLÜSSIGKEITSDRUCK AUS DEM GESAMTEN SPRÜHSYSTEM, EINSCHLIESSLICH DER SPRÜHANLAGE, DES SCHLAUCHS UND DER PISTOLE ENTFERNEN, BEVOR SIE DEN SCHLAUCH ENTFERNEN! Schalten Sie Ihre Sprühanlage aus und befolgen Sie den Druckausgleichablauf wie im Handbuch zur Ausrüstung angegeben. Auslösersperre aktivieren. Trennen Sie den Schlauch von der Verbindung unten an Ihrer Pistole.

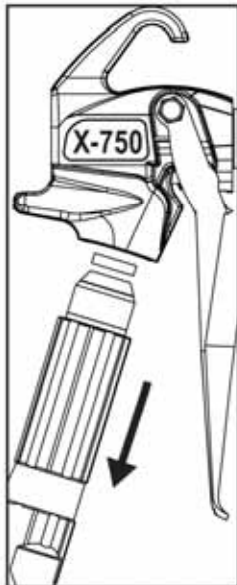

Disconnect fluid hose from base of gun. Using a 3/4" or 19mm wrench or an adjustable wrench, unscrew and remove the handle from the head of the gun using the flat areas at the base of the handle. Be sure to retain the white nylon gasket between the gun handle and gun head.

Disconnect fluid hose from base of gun. Using a 3/4" or 19mm wrench or an adjustable wrench, unscrew and remove the handle from the head of the gun using the flat areas at the base of the handle. Be sure to retain the white nylon gasket between the gun handle and gun head.

Disconnect fluid hose from base of gun. Using a 3/4" or 19mm wrench or an adjustable wrench, unscrew and remove the handle from the head of the gun using the flat areas at the base of the handle. Be sure to retain the white nylon gasket between the gun handle and gun head.

Disconnect fluid hose from base of gun. Using a 3/4" or 19mm wrench or an adjustable wrench, unscrew and remove the handle from the head of the gun using the flat areas at the base of the handle. Be sure to retain the white nylon gasket between the gun handle and gun head.



XM-Series Pneumatic Airless Sprayers

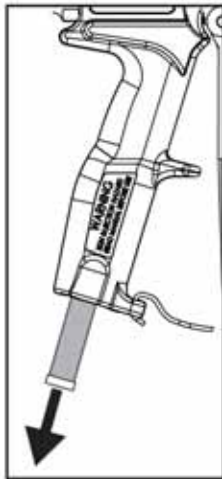

Slide filter out from bottom of gun handle. Clean and flush the inside fluid passages of the gun handle. Install new filter with open end of filter into gun handle first. Reattach hose connection fitting. Make sure the spring is inside the hose connection fitting. Tighten securely with 13/16" or 21mm wrench or adjustable wrench. Reattach fluid hose.

NOTE: Use only ATOMEX original replacement parts and filters in order to keep your gun in top operating condition and maintain your warranty coverage. Use of aftermarket or non-ATOMEX parts will void your warranty.

Faire sortir le filtre du bas de la poignée du pistolet. Nettoyer et rincer les traces de produit de la poignée du pistolet. Installer un nouveau filtre avec l'extrémité ouverte du filtre dans la poignée du pistolet d'abord. Raccorder la fixation de raccord du flexible. S'assurer que le ressort est bien à l'intérieur de la fixation du raccord du flexible. Bien serrer avec une clé 13/16" ou 21 mm ou une clé à molette. Raccorder le flexible produit.

REMARQUE : n'utiliser que des pièces de rechange originales ATOMEX afin de garder le pistolet dans des conditions optimales de fonctionnement et de conserver votre garantie. L'utilisation de pièces de rechange autres que ATOMEX annulera votre garantie.

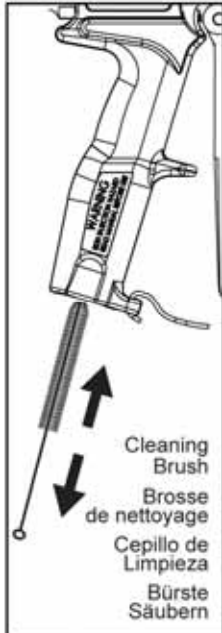

Cleaning
Brush
Brosse
de nettoyage
Cepillo de
Limpieza
Bürste
Säubern

Deslice el filtro hacia fuera de la parte inferior de la empuñadura de la pistola. Limpie y lave el interior de los conductos de líquidos de la empuñadura de la pistola. Instale en la empuñadura de la pistola un filtro nuevo, primero con su extremo abierto. Reconecte el accesorio de conexión de la manguera. Asegúrese de que el resorte esté dentro del accesorio de conexión de la manguera. Apriete bien con una llave de 13/16" o 21 mm o con una llave ajustable. Reconecte la manguera de líquidos.

OBSERVACIÓN: Utilice únicamente piezas de repuesto y filtros originales de ATOMEX para mantener la pistola en el mejor estado de funcionamiento posible y asegurar la cobertura de garantía. La utilización de piezas no fabricadas por ATOMEX anulará la garantía.

Ziehen Sie den Filter vom Boden der Pistolenhalterung heraus. Säubern Sie die innen liegenden Flüssigkeitsdurchläufe der Pistolenhalterung und spülen Sie sie durch. Bringen Sie den neuen Filter mit dem offenen Ende des Filters zuerst in die Pistolenhalterung ein. Bringen Sie die Schlauchverbindung wieder an. Stellen Sie sicher, dass die Feder in der Schlauchverbindung ist. Ziehen Sie sie fest mit einem 13/16"- oder 21mm-Schlüssel oder einem verstellbaren Schlüssel an. Flüssigkeitsschlauch wieder anschließen.

HINWEIS: Verwenden Sie nur ATOMEX Originalersatzteile und Filter, um beste Betriebsbedingungen für Ihre Pistole zu gewährleisten und um Ihre Garantieabdeckung nicht zu verlieren. Verwenden Sie Teile aus Ersatzteilmärkten oder keine ATOMEX-Teile, verlieren Sie Ihre Garantie.



ATOMEX Original Replacement Filters

Part No.	Mesh	Color
AX/W0034377	50	White
AX/W0043235	100	Yellow
AX/W0034383	200	Red

⚠ WARNING

Cleaning with Solvents

Nettoyage avec solvants

Limpieza con solventes

Reinigung mit Lösungsmitteln



- Always flush gun outside if possible and at least 25' - 7.5m away from sprayer.
- Area must be free of flammable vapors.
- Always flush at minimum pressure. Always remove tip and guard.
- Static electricity buildup may result in fire or explosion in the presence of flammable vapors.
- Always hold the gun firmly against a grounded, metal container when flushing.
- Toujours rincer le pistolet à l'extérieur si possible et au moins à 25' (7,5 m) du pulvérisateur.
- La zone ne doit pas contenir de vapeurs inflammables.
- Toujours rincer à une pression minimale. Toujours enlever la buse et la garde.
- La formation d'électricité statique peut provoquer un incendie ou une explosion en présence de vapeurs inflammables.
- Pendant le rinçage, toujours maintenir le pistolet fermement contre un conteneur métallique relié à la terre.
- Siempre que sea posible, lave la pistola al aire libre y por lo menos a una distancia 7,5 metros del pulverizador.
- El área debe estar exenta de vapores inflamables.
- Siempre lave a la presión mínima. Quite siempre la boquilla y el protector.
- La acumulación de electricidad estática podría causar incendio o explosión en presencia de vapores inflamables.
- Al lavar, sujete siempre firmemente la pistola contra un recipiente metálico conectado a tierra.
- Wenn möglich spülen Sie die Pistole immer außerhalb und in einer Entfernung von wenigstens 25' - 7,5m vom Sprühgerät aus.
- Der Bereich muss frei von entflammabaren Dämpfen sein.
- Spülen Sie immer bei minimalem Druck aus. Entfernen Sie immer Düse und Schutz.
- Aufbau statischer Elektrizität kann zu Feuer oder Explosion führen beim Vorhandensein von entflammabaren Dämpfen.
- Halten Sie die Pistole beim Durchspülen fest gegen einen geerdeten, metallischen Behälter.

Replacing the valve stem assembly Remplacement de l'unité de la tige de vanne Cambio del conjunto de vástago de válvula Ersetzung der Ventilschaftanordnung

**Locked
Verrouillée
Bloqueado
Gesperrt**



Relieve fluid pressure from your entire spray system. Engage trigger lock and disconnect fluid hose from gun. Remove tip and guard.

Décompresser l'ensemble du système de pulvérisation. Verrouiller la gâchette et déconnecter le flexible produit du pistolet. Enlever la buse et la garde.

Realice la descompresión de todo el sistema de pulverización. Trabe el seguro del gatillo y desconecte de la pistola la manguera de líquidos. Retire la boquilla y el protector.

Lassen Sie den Flüssigkeitsdruck aus Ihrem gesamten Sprühsystem ab. Aktivieren Sie die Auslösersperre und trennen Sie den Flüssigkeitsschlauch von der Pistole. Entfernen Sie Düse und Schutz.

Unlock and engage trigger - then: **1.** Unscrew and remove diffuser from the front of the gun. **2.** Release trigger and unscrew and remove end cap from back of gun head and remove the spring from the cavity.



Déverrouiller et verrouiller la gâchette. Puis, **1.** dévisser et enlever le diffuseur de la partie avant du pistolet. **2.** Relâcher la gâchette et dévisser et enlever le bouchon de protection de l'arrière de la tête du pistolet et sortir le ressort de sa cavité.

Desbloquee y trabe el gatillo y luego: **1.** Desenrosque y retire el difusor de la parte delantera de la pistola. **2.** Suelte el gatillo y desenrosque y retire el capuchón de la parte posterior del cabezal de la pistola y extraiga el resorte de la cavidad.

Entsperren und aktivieren Sie den Auslöser - dann: **1.** Schrauben Sie den Diffusor ab und entfernen Sie ihn von der Vorderseite der Pistole. **2.** Lassen Sie den Auslöser los und schrauben Sie die Abschlusskappe vom Hinterteil des Pistolenkopfs ab und ziehen Sie die Feder aus der Aushöhlung.

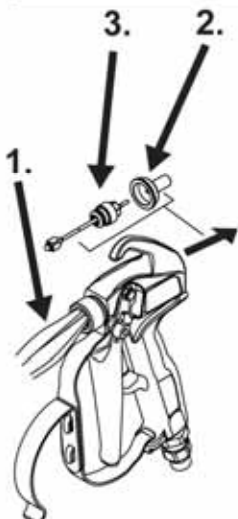

1. Use long nose pliers to hold front of valve stem - then **2.** unscrew and remove retractor knob from the inside of the back of the gun head. **3.** Unscrew and remove seal housing from the back of the gun head using a 5/16" or 8mm socket.

1. Utilisez les longues pinces de nez pour tenir l'avant de la tige de valve - puis. **2.** Utiliser un outil de jointage fourni avec le kit de réparation pour maintenir l'avant de la tige de vanne, puis dévisser et enlever le logement de joint à l'arrière de la tête du pistolet au moyen d'une douille 8mm ou 5/16".

1. Utilice los alicates largos de la nariz para llevar a cabo el frente del vástago de válvula - entonces. **2.** Utilice la herramienta de sellado suministrada con el kit de reparación para sujetar el vástago de válvula. Desenrosque y retire el alojamiento del sello de la parte posterior del cabezal de la pistola mediante un adaptador de 8mm o 5/16".

1. Benutzen Sie lange Nase Zangen, um Frontseite des Ventilschafts zu halten - dann. **2.** Verwenden Sie das Dichtungswerkzeug aus dem Reparatur-Set, um den Vorderteil des Ventilschafts zu halten - schrauben Sie dann das Dichtungsgehäuse vom hinteren Teil des Pistolenkopfs ab und entfernen Sie ihn unter Verwendung 8mm - oder 5/16" Muffe.



Clean and flush the fluid passages of the gun. **DO NOT** use a sharp object to do this. Only use a soft brush or rag.

Nettoyer et rincer les traces de produit du pistolet. **NE PAS** utiliser d'objet pointu pour cette opération. N'utiliser qu'une brosse ou un chiffon tendre.

Limpie y lave los conductos de líquidos de la pistola. **NO** utilice objetos afilados para hacerlo, sino únicamente un cepillo suave o un trapo.

Säubern Sie die Flüssigkeitsdurchläufe der Pistolenhalterung und spülen Sie sie durch. Verwenden Sie **KEINEN** scharfen Gegenstand, um dies zu tun. Verwenden Sie nur eine weiche Bürste oder einen Lappen.



Apply grease to the o-ring on the new seal housing. **Use ONLY nonsilicon grease.**

Appliquez de la graisse sur le joint torique du nouveau logement de joint. **N'UTILISER que de la graisse sans silicone.**

Aplique grasa en la junta tórica del nuevo alojamiento del sello. **Utilice ÚNICAMENTE grasa sin siliconas.**

Bringen Sie Schmierfett auf den O-Ring auf dem neuen Dichtungsgehäuse an. **Verwenden Sie NUR Schmierfett ohne Silikon.**

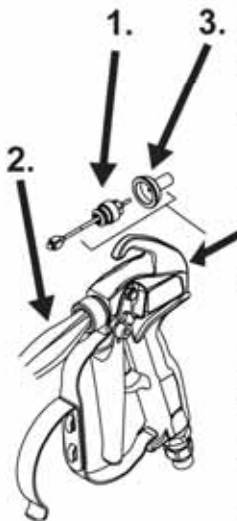

1. Insert new seal housing and valve stem into the rear of the gun. Thread the seal housing in (clockwise) until it stops. Tighten with 9/16" or 14mm socket - **DO NOT OVERTIGHTEN**. 2. While holding front of valve stem with long nose pliers - 3. thread the new retractor knob onto the end of the valve stem from the back of the gun and tighten **by hand** until it stops. **DO NOT USE TOOLS TO TIGHTEN KNOB - DO NOT OVERTIGHTEN.**

Insérer le nouveau logement de joint et la tige de vanne à l'arrière du pistolet. Guider le logement du joint (dans le sens des aiguilles d'une montre) jusqu'au blocage. Serrer avec une douille 9/16" ou 14 mm. **NE PAS TROP SERRER.** Tout en tenant l'avant de la tige de valve avec de longues pinces de nez, faire passer le nouveau bouton du rétracteur sur l'extrémité de la tige de vanne à l'arrière du pistolet et serrer jusqu'au blocage.

Inserte en la parte posterior de la pistola el nuevo alojamiento de sello y el vástago de válvula. Introduzca el alojamiento de sello en el sentido horario, hasta que se detenga. Apriete con un adaptador de 9/16" o 14 mm: **NO APRIETE DEMASIADO.** Mientras que lleva a cabo el frente del vástago de válvula con los alicates largos de la nariz, introduzca la nueva perilla de retractor en el extremo del vástago de la parte posterior de la pistola y apriete hasta que se detenga.

1. Setzen Sie ein neues Dichtungsgehäuse mit Ventilschaft an der Rückseite der Pistole ein. Schrauben Sie das Dichtungsgehäuse im Uhrzeigersinn ein bis zum Anschlag. Ziehen Sie das Gehäuse mit einem 14-er Gabelschlüssel an. **Achtung: Nicht überdrehen !!**

2. + 3. Während Sie das vordere Teil des Ventilschaftes mit einer Zange festhalten, schrauben Sie eine neue Spannschraube auf das hintere Teil des Ventilschaftes und ziehen Sie diese von Hand bis zum Anschlag an.

Benutzen Sie dafür kein Werkzeug und überdrehen Sie diese Schraube nicht.



1. Insert new retractor spring into back of gun. Thread end cap onto back of gun and tighten securely. Engage trigger, then 2. thread new diffuser on to front of gun and tighten securely while keeping trigger engaged.

Insérer le nouveau ressort du rétracteur dans l'arrière du pistolet. Faire passer le bouchon de protection sur l'arrière du pistolet et bien serrer.

Verrouiller la gâchette, puis faire passer le nouveau diffuseur sur l'avant du pistolet et bien serrer tout en gardant la gâchette verrouillée.

Inserte el nuevo resorte retractor en la parte posterior de la pistola.

Introduzca el capuchón en la parte posterior de la pistola y ciérrelo bien.

Trabe el gatillo, introduzca el nuevo difusor en la parte frontal de la pistola y ciérrelo bien manteniendo trabado el gatillo.

Führen Sie eine neue Retraktorfeder in die Rückseite der Pistole ein.

Bringen Sie die Abschlussklappe auf die Rückseite der Pistole an und ziehen Sie sie fest an.

Aktivieren Sie den Auslöser, bringen Sie dann den neuen Diffusor auf die Vorderseite der Pistole an und ziehen Sie ihn fest an,

während Sie den Auslöser aktiviert halten.



XM-Series Pneumatic Airless Sprayers

Parts Drawing for your X-750 Spray Gun
Schémas des pièces pour le Pistolet Pulvérisateur X-750
Diagrama de piezas de la pistola de pulverización X-750
Teilezeichnung für Ihre X-750 Spritzpistole

Parts List:			
Item	Part#	Description	Quantity
1		Diffuser	1
2	AX/02-750-501	Handle - 7/8"	1
2	AX/02-750-502	Handle - 11/16"	1
3		Stem / Seal Assembly	1
4		Trigger Pin	2
5		Knob, Retractor	1
6		Spring, Retractor	1
7	AX/02-750-503	Cap	1
8	AX/02-750-500	KIT, Repair - 7/8" and 11/16"	
9	AX/02-750-504	Hook	1
10	AX/01-400-000	Guard, Trigger	1
11	AX/02-750-505	Nut, Trigger	1
12	AX/02-750-506	Shaft, Trigger	1
13	AX/02-360-507	Trigger, 4-Finger	1
13	AX/02-360-508	Trigger, 2-Finger	1
14	AX/W0034377	Filter, 50 Mesh	1
15	AX/02-360-510	Spring, Filter	1
16	AX/02-750-509	Swivel, Hose Connection	1



XM-Series Pneumatic Airless Sprayers

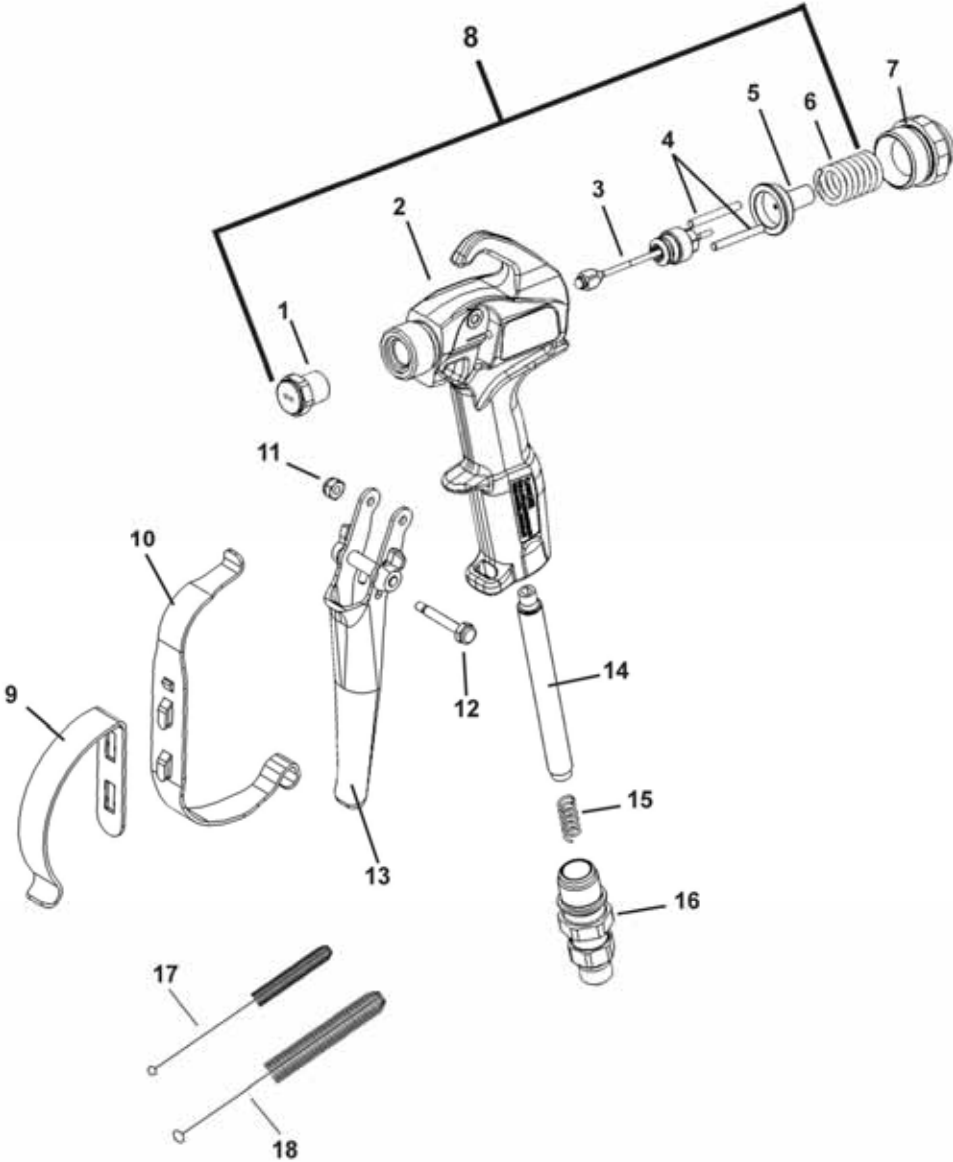



XM-Series Pneumatic Airless Sprayers

Parts Drawing for your X-75HD Spray Tip and Guard
Schémas des pièces pour l Buse et le garde-buse
du Pulvérisateur X-75HD
Diagrama de piezas de la boquilla y portaboquillas X-75HD
Teilezeichnung für Ihre X-75HD Spritzdüse und Schutz

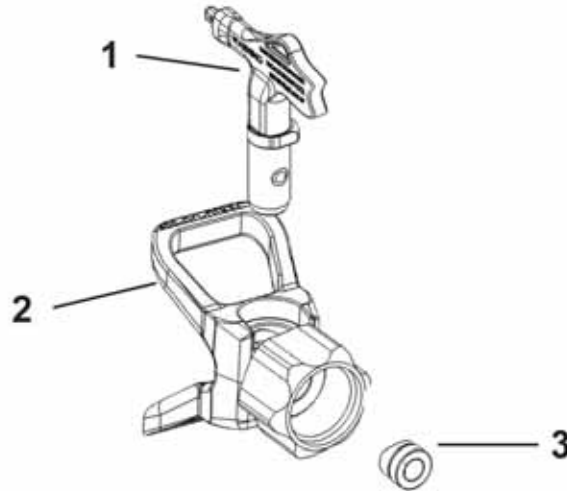

Parts List:			
Item	Part#	Description	Quantity
1	AX/01-200-XXX	X-75M Reversible Tip	1
2	AX/01-400-000	X-75 7500psi Tip Guard 7/8"	1
	AX/01-400-001	X-75 7500psi Tip Guard 11/16"	1
3	AX/01-100-000	X Series Tip + Seal Gasket	1



Technical Data for your X-750 Spray Gun
Données techniques pour le Pistolet Pulvérisateur X-750
Información técnica de la pistola de pulverización X-750
Technische Daten für Ihre X-750 Spritzpistole

Maximum Working Pressure.....	7500 PSI (500 bar, 50.0 Mpa)
Weight with Tip and Guard.....	19.2 oz. (550 g)
Hose Inlet Connection.....	1/4 in NPSM Swivel
Wetted Parts.....	Stainless steel, polyethylene, nylon, aluminum, tungsten carbide



XM-Series Pneumatic Airless Sprayers

LIMITED WARRANTY

ATOMEX warrants that at the time of original receipt, purchase and/or delivery to the original purchaser for use, the product(s) covered by this warranty is/are free from defects in the material and workmanship in its manufacture. With the exception of any special, limited, or extended warranty published by ATOMEX, ATOMEX's obligation under this warranty is limited to repairing without charge or replacing those parts which, to ATOMEX's reasonable satisfaction, are shown to be defective within twelve (12) months after sale to the original purchaser. This warranty applies only when the product is installed and operated in accordance with the instructions of ATOMEX.

This warranty does not apply in the case of damage or wear caused by abrasion, corrosion or misuse, negligence, accident, faulty installation, substitution of non-ATOMEX component parts, or tampering with the product in a manner that will or has impair(ed) normal operation.

Defective parts must to be returned to an authorized sales or service company or ATOMEX. All transportation and/or shipping charges, including return to the factory, if necessary, are the responsibility of the original purchaser. Repaired or replaced products will be returned to the original purchaser with transportation and/or shipping charges prepaid by ATOMEX.

THERE IS NO OTHER EXPRESSED WARRANTY. ATOMEX HEREBY DISCLAIMS ANY AND ALL IMPLIED WARRANTIES INCLUDING, BUT NOT LIMITED TO, THOSE OF MERCHANTABILITY AND FITNESS FOR A PARTICULAR PURPOSE, TO THE EXTENT PERMITTED BY LAW. THE DURATION OF ANY IMPLIED WARRANTIES WHICH CANNOT BE DISCLAIMED IS LIMITED TO THE TIME PERIOD SPECIFIED IN THE EXPRESS WARRANTY. IN NO CASE SHALL ATOMEX'S LIABILITY EXCEED THE AMOUNT OF THE PURCHASE PRICE. LIABILITY FOR CONSEQUENTIAL, INCIDENTAL OR SPECIAL DAMAGES UNDER ANY AND ALL WARRANTIES IS EXCLUDED TO THE EXTENT PERMITTED BY LAW.

All data and information, both written and visual, communicated in the manual represents the current and latest information available at the time this document was printed or posted. ATOMEX, Incorporated reserves the right to make changes and update information at any time and without notice.



ATOMEX
29 Carlingford Street
Regents Park NSW 2143
Phone: (02) 9644 1040
Fax: (02) 9644 3147
Email: info@atomex.com.au
www.atomex.com.au

