

Repair



ProConnect Endurance Displacement Pump

334599D

EN

For professional use only.

Models: 17C487, 17C488, 17C489, 17C721



Important Safety Instructions

Read all warnings and instructions in this manual and related manuals.
Be familiar with the controls and the proper usage of the equipment.
Save these instructions.

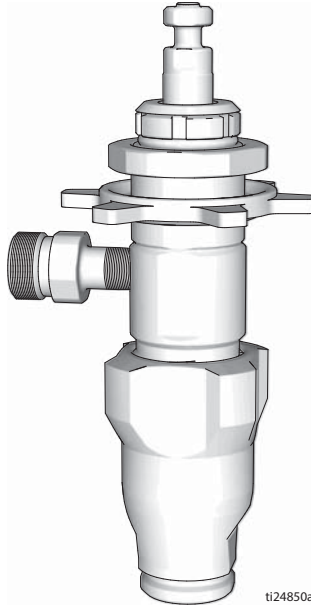

t124850a

*Use only genuine Graco replacement parts.
The use of non-Graco replacement parts may void warranty.*

PROVEN QUALITY. LEADING TECHNOLOGY.

Contents

Warnings	3
Pressure Relief	5
Trigger Lock	5
Pressure Relief Procedure	5
Pump Removal	7
Repair	8
Dissemble Pump	8
Assemble Pump	10
Parts	15
Parts List	16
Pump Installation	17
Technical Specifications	18
Graco Standard Warranty	19
Graco Information	20

Warnings

The following warnings are for the setup, use, grounding, maintenance, and repair of this equipment. The exclamation point symbol alerts you to a general warning and the hazard symbols refer to procedure-specific risks. When these symbols appear in the body of this manual or on warning labels, refer back to these Warnings. Product-specific hazard symbols and warnings not covered in this section may appear throughout the body of this manual where applicable.

WARNING



FIRE AND EXPLOSION HAZARD

Flammable fumes, such as solvent and paint fumes, in work area can ignite or explode. To help prevent fire and explosion:

- Do not spray flammable or combustible materials near an open flame or sources of ignition such as cigarettes, motors, and electrical equipment.
- Paint or solvent flowing through the equipment is able to result in static electricity. Static electricity creates a risk of fire or explosion in the presence of paint or solvent fumes. All parts of the spray system, including the pump, hose assembly, spray gun, and objects in and around the spray area shall be properly grounded to protect against static discharge and sparks. Use Graco conductive or grounded high-pressure airless paint sprayer hoses.
- Verify that all containers and collection systems are grounded to prevent static discharge. Do not use pail liners unless they are anti static or conductive.
- Connect to a grounded outlet and use grounded extensions cords. Do not use a 3-to-2 adapter.
- Do not use a paint or a solvent containing halogenated hydrocarbons.
- Do not spray flammable or combustible liquids in a confined area.
- Keep spray area well-ventilated. Keep a good supply of fresh air moving through the area.
- Sprayer generates sparks. Keep pump assembly in a well ventilated area at least 20 feet (6.1 m) from the spray area when spraying, flushing, cleaning, or servicing. Do not spray pump assembly.
- Do not smoke in the spray area or spray where sparks or flame is present.
- Do not operate light switches, engines, or similar spark producing products in the spray area.
- Keep area clean and free of paint or solvent containers, rags, and other flammable materials.
- Know the contents of the paints and solvents being sprayed. Read all Safety Data Sheets (SDS) and container labels provided with the paints and solvents. Follow the paint and solvents manufacturer's safety instructions.
- Fire extinguisher equipment shall be present and working.

Warnings

WARNING



SKIN INJECTION HAZARD

High-pressure spray is able to inject toxins into the body and cause serious bodily injury. In the event that injection occurs, **get immediate surgical treatment**.

- Do not aim the gun at, or spray any person or animal.
- Keep hands and other body parts away from the discharge. For example, do not try to stop leaks with any part of the body.
- Always use the nozzle tip guard. Do not spray without nozzle tip guard in place.
- Use Graco nozzle tips.
- Use caution when cleaning and changing nozzle tips. In the case where the nozzle tip clogs while spraying, follow the **Pressure Relief Procedure** for turning off the unit and relieving the pressure before removing the nozzle tip to clean.
- Equipment maintains pressure after power is shut off. Do not leave the equipment energized or under pressure while unattended. Follow the **Pressure Relief Procedure** when the equipment is unattended or not in use, and before servicing, cleaning, or removing parts.
- Check hoses and parts for signs of damage. Replace any damaged hoses or parts.
- This system is capable of producing 3300 psi. Use Graco replacement parts or accessories that are rated a minimum of 3300 psi.
- Always engage the trigger lock when not spraying. Verify the trigger lock is functioning properly.
- Verify that all connections are secure before operating the unit.
- Know how to stop the unit and bleed pressure quickly. Be thoroughly familiar with the controls.



PRESSURIZED ALUMINUM PARTS HAZARD

Use of fluids that are incompatible with aluminum in pressurized equipment can cause serious chemical reaction and equipment rupture. Failure to follow this warning can result in death, serious injury, or property damage.

- Do not use 1,1,1-trichloroethane, methylene chloride, other halogenated hydrocarbon solvents or fluids containing such solvents.
- Do not use chlorine bleach.
- Many other fluids may contain chemicals that can react with aluminum. Contact your material supplier for compatibility.



TOXIC FLUID OR FUMES HAZARD

Toxic fluids or fumes can cause serious injury or death if splashed in the eyes or on skin, inhaled, or swallowed.

- Read SDSs to know the specific hazards of the fluids you are using.
- Store hazardous fluid in approved containers, and dispose of it according to applicable guidelines.



PERSONAL PROTECTIVE EQUIPMENT

Wear appropriate protective equipment when in the work area to help prevent serious injury, including eye injury, hearing loss, inhalation of toxic fumes, and burns. This protective equipment includes but is not limited to:

- Protective eye wear, and hearing protection.
- Respirators, protective clothing, and gloves as recommended by the fluid and solvent manufacturer.

CALIFORNIA PROPOSITION 65

This product contains a chemical known to the State of California to cause cancer, birth defects or other reproductive harm. Wash hands after handling.

Pressure Relief

Trigger Lock

Always engage the trigger lock when sprayer is stopped to prevent the gun from being triggered accidentally by hand or if dropped or bumped.

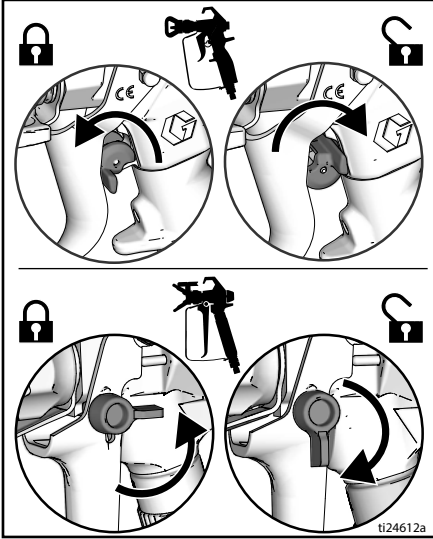

1. Engage the trigger lock.

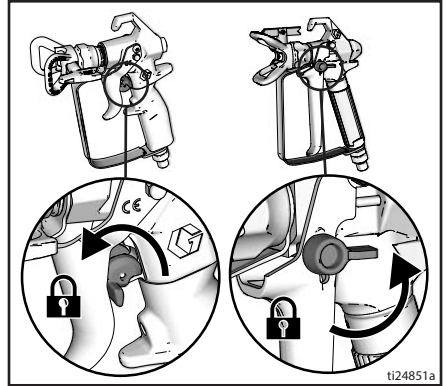

2. Turn the ON/OFF switch to **OFF** position. Wait 7 seconds for power to dissipate.

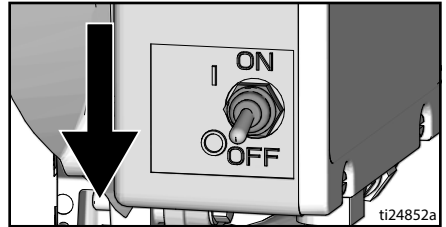

Pressure Relief Procedure



This equipment stays pressurized until pressure is manually relieved. To help prevent serious injury from pressurized fluid, such as skin injection, splashed fluid and moving parts, follow the Pressure Relief Procedure whenever sprayer is stopped and before sprayer is cleaned or checked, and before equipment is serviced.

3. Unplug power cord or shut engine off.

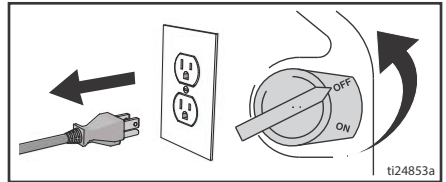

4. Engage the trigger lock.
5. Remove tip guard.

Pressure Relief

6. Turn pressure control to the lowest setting. Disengage trigger lock.

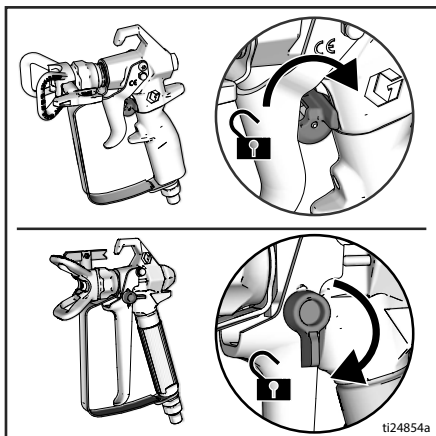

8. Engage the trigger lock.

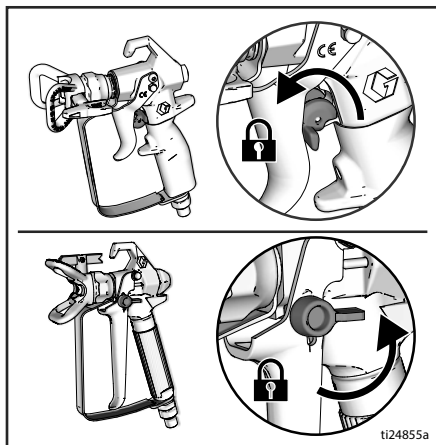

7. Hold a metal part of the gun firmly to a grounded metal pail. Trigger the gun to relieve pressure.

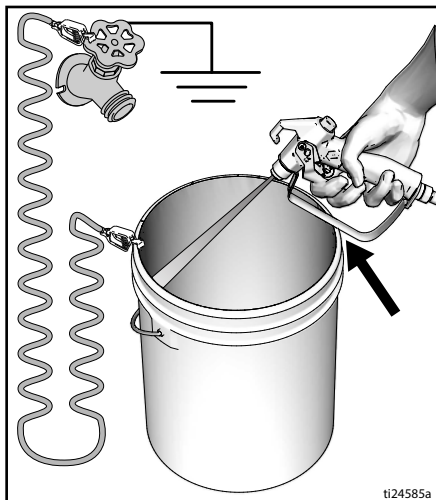

9. Open any fluid drain valves in system. Leave drain valves open until ready to spray again.

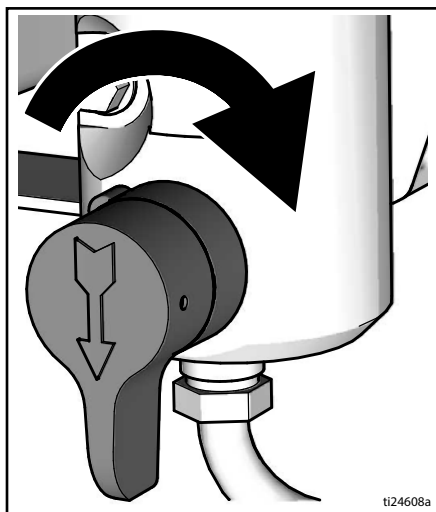

Pump Removal

Pump removal includes disconnecting the fluid inlet and outlet and removing the pump.

1. Use a hammer to loosen pump retaining nut.

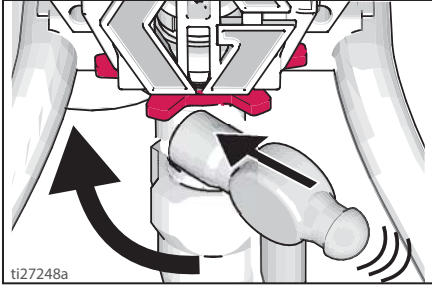

2. Turn pump retaining nut to free pump rod cover.

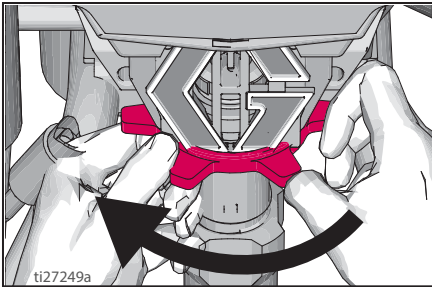

3. Swing pump rod cover open.

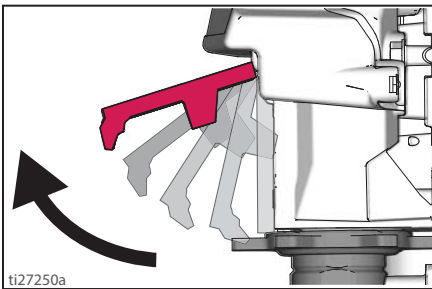

4. Disconnect outlet hose and suction hose from pump.

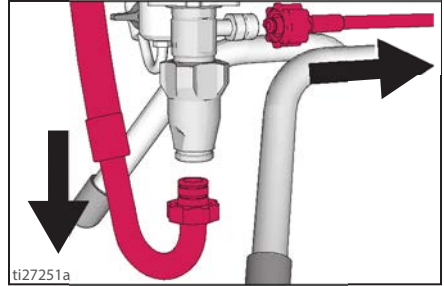

5. Slide pump out of the drive housing.

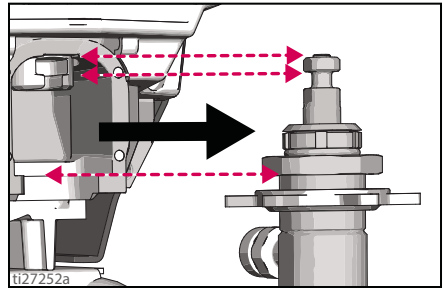

Repair

Disassemble Pump

1. Remove packing nut and throat adjustment spacer. Retaining nuts are not removable and not sold separately.

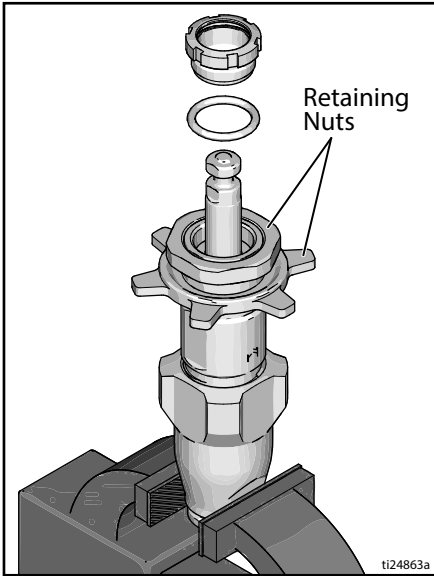

2. Unscrew cylinder from intake valve.

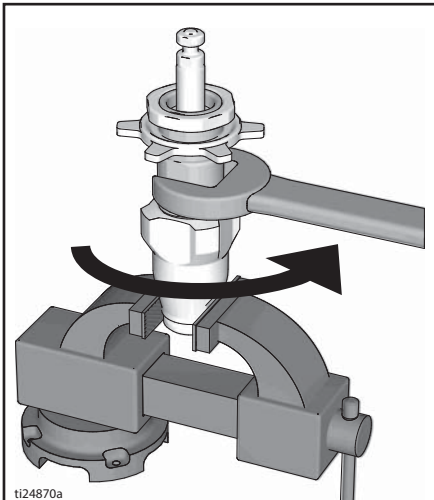

3. Disassemble intake valve. Clean and inspect. O-ring may require a pick for removal.

NOTICE

If using a pick to remove the O-ring use care to avoid damage to the machined surfaces.

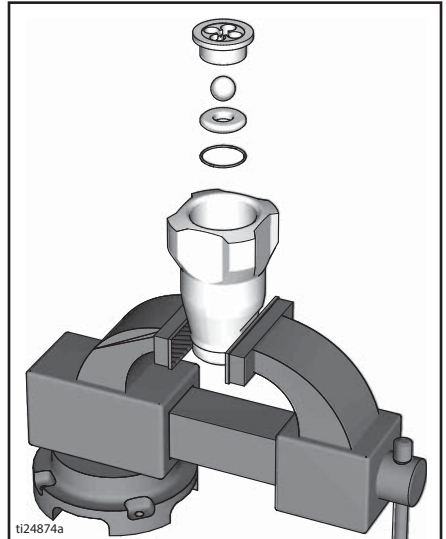

4. Tap piston rod out of cylinder with a hammer or flip over and tap piston rod out against a bench.

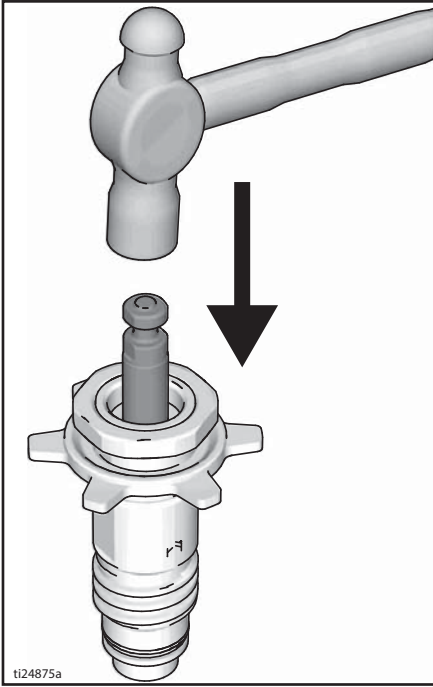

--	--	--	--	--

Do not clean or wipe the piston valve threads. Cleaning the piston valve threads could destroy the special sealing patch and cause the piston valve to come loose during operation, causing a pump burst and possible serious bodily injury.

5. Unscrew piston valve from piston rod.

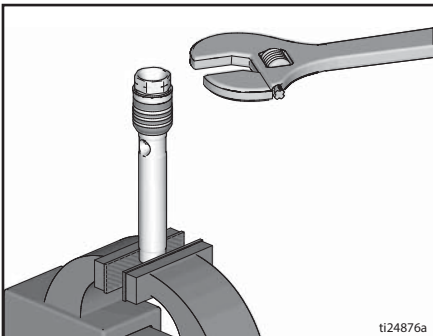

6. Clean and inspect parts. (The piston has a special thread locking/sealing patch. Apply thread sealant to the threads.)

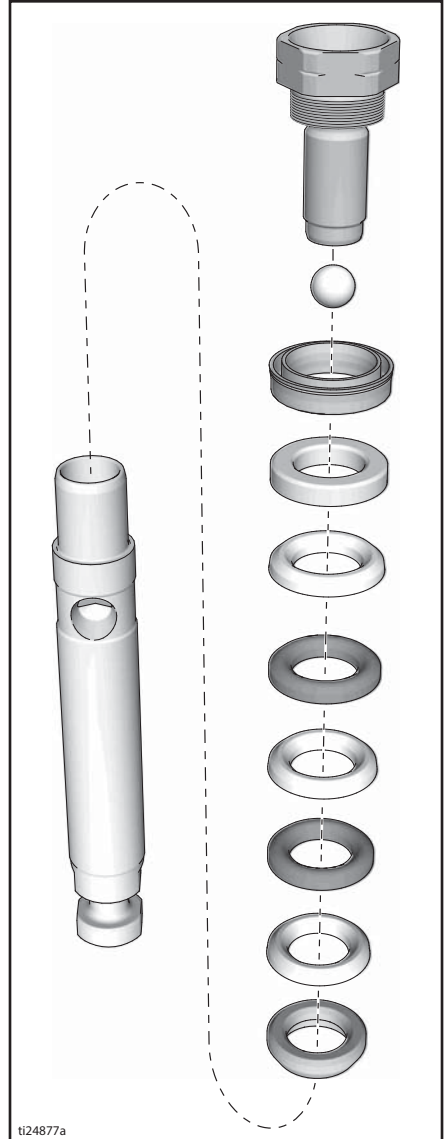

Repair

7. Remove and discard throat packing and glands from the cylinder.

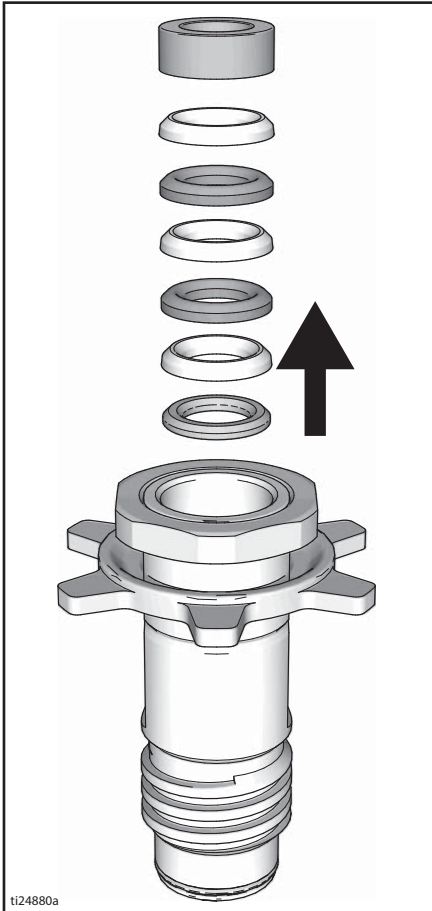

Assemble Pump

1. Soak leather packings in SAE 30W oil for one hour before assembly.

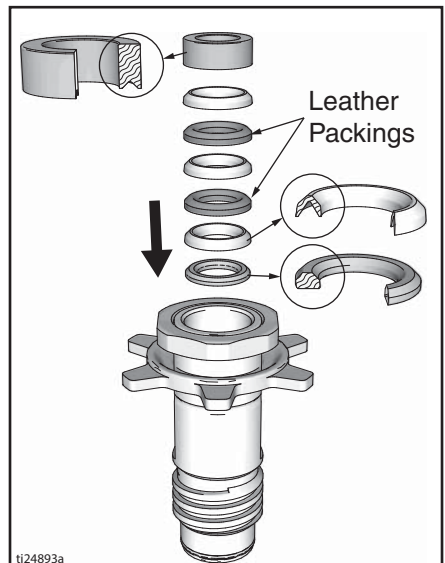
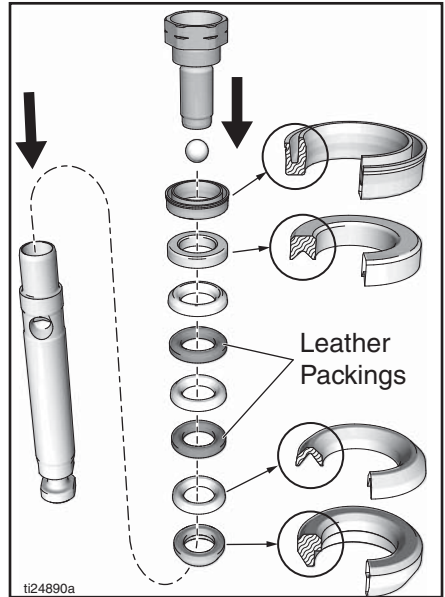

2. Install ball in piston rod. If thread sealant is applied to piston valve threads, ensure that none gets on the ball.

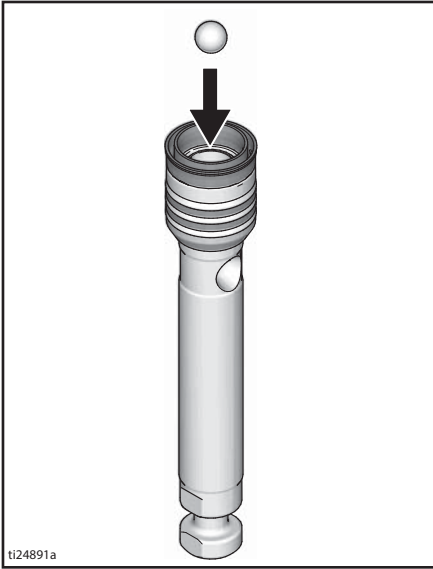

3. Torque to 27 ± 3 ft-lb (37 ± 4 N•m).

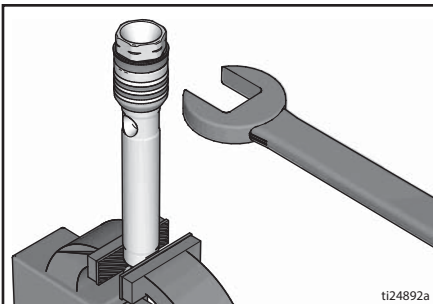

4. Assemble leather throat packings soaked earlier.

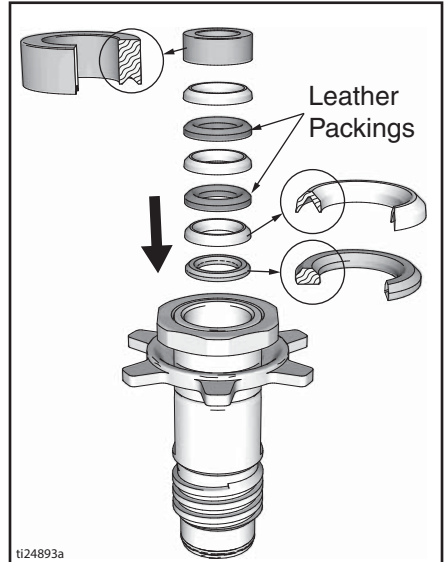

5. Loosely install packing nut with o-ring onto cylinder.

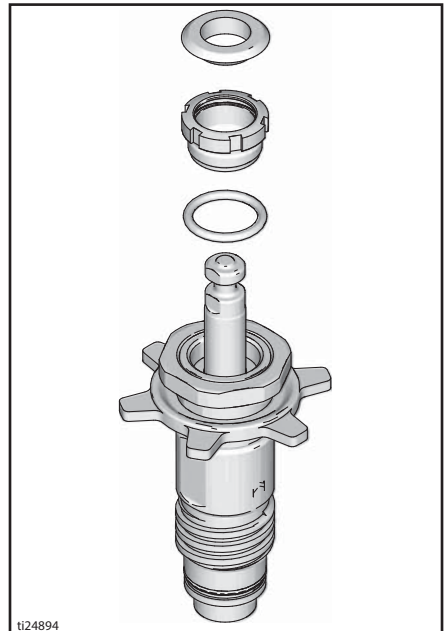

Repair

6. Apply liberal amounts of grease or oil to piston packings.

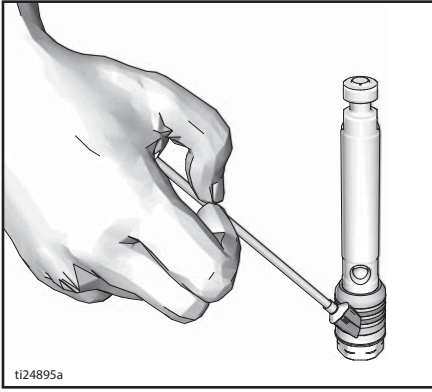

8. Grease o-ring and place on outside diameter ring groove.

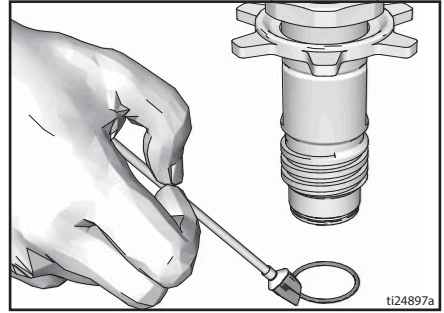

7. Grease top inch or two of piston rod that will go through the cylinder throat packings. Gently guide displacement rod up through throat packings. Tap bottom of piston valve as necessary with a leather or plastic hammer.

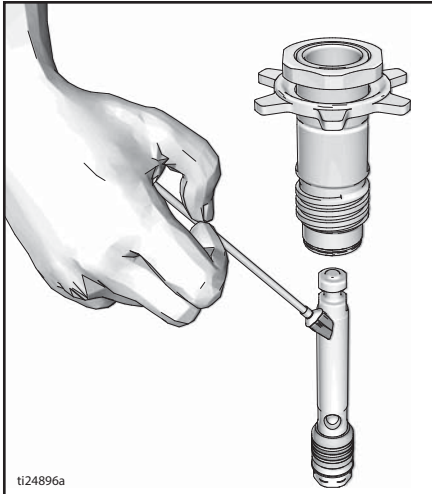

9. Clean seat thoroughly. Reassemble intake valve with a seat, ball, and new o-ring. Seat may be flipped over and used on other side.

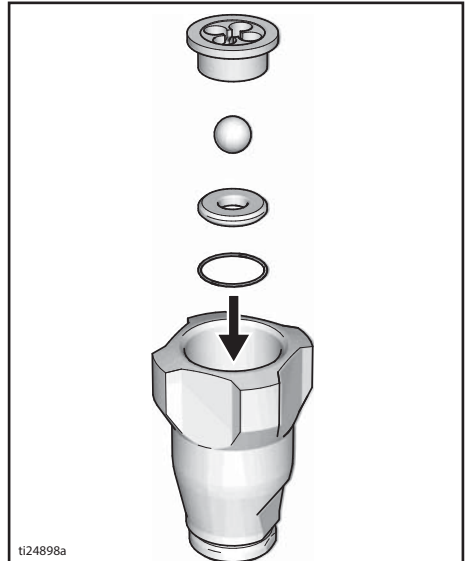

10. Torque to 100 ± 5 ft-lb (136 ± 7 N•m).

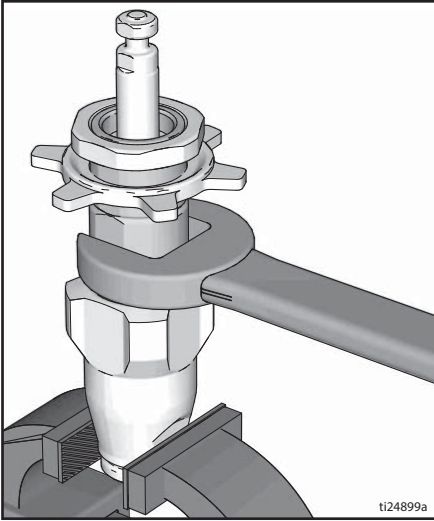

11. Install o-ring onto packing nut. Torque to 75 ± 5 in-lb (8.5 ± 0.5 N•m) or additional 1/2 turn from hand tight.

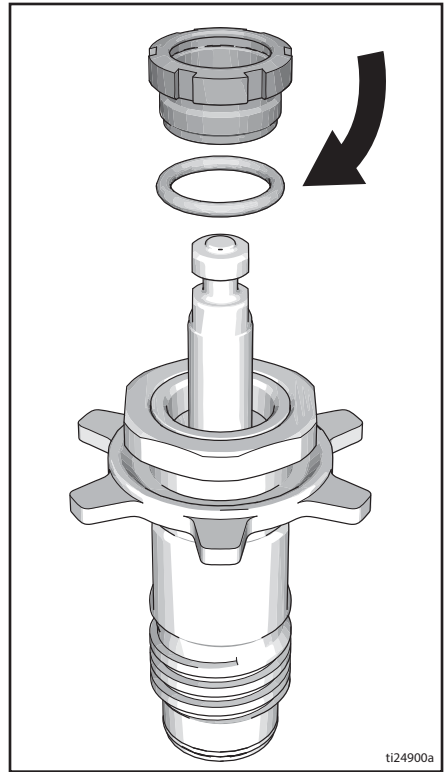

12. Storage



Throat Packing Adjustment



This equipment stays pressurized until pressure is manually relieved. To help prevent serious injury from pressurized fluid, such as skin injection, splashed fluid and moving parts, follow the **Pressure Relief Procedure** whenever sprayer is stopped and before sprayer is cleaned or checked, and before equipment is serviced.

When pump packings begin to leak after much use, perform **Pressure Relief Procedure**, page 5 and tighten packing nut down until leakage stops or lessens. This allows approximately 100 gallons of additional operation before a repacking is required. Packing nut can be tightened without o-ring removal.

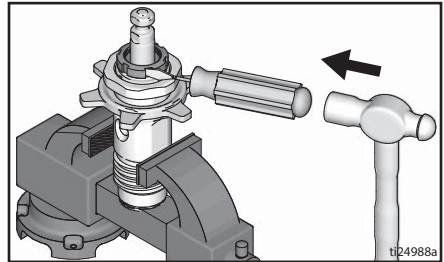

Parts

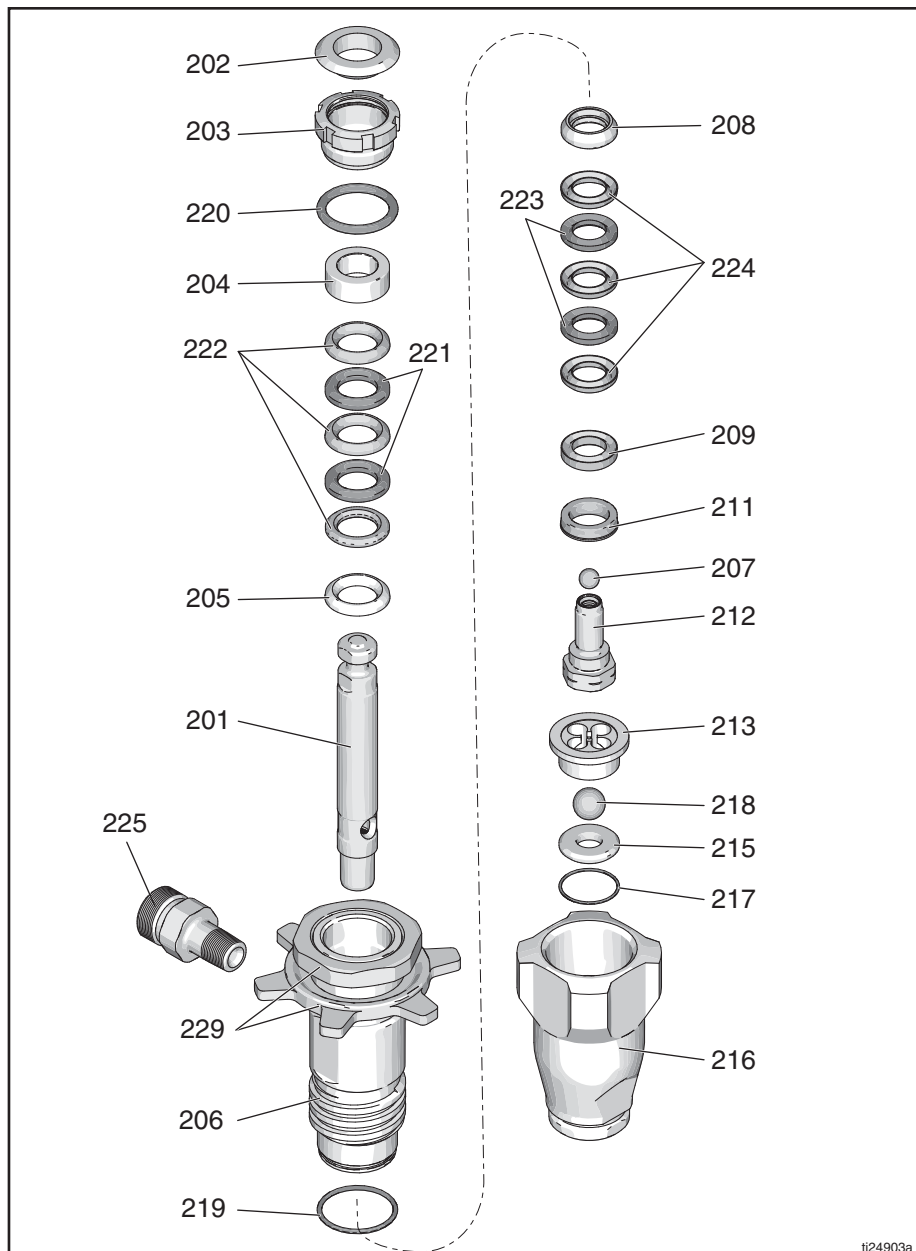

ti24903a

Parts List

Ref.	Part	Description	Qty.	Ref.	Part	Description	Qty.
201	24W617	ROD, displacement, <i>includes 212</i>	1	217*†	15B112	PACKING, o-ring (0.941 in. OD)	1
202*	180656	BUTTON, plug	1	218*†	105445	BALL, sst, 0.5000 in.	1
203	193047	NUT, packing	1	219*	108526	O-RING, PTFE	1
204*	176757	GLAND, female, throat	1	220*	160516	O-RING	1
205*	176754	GLAND, male throat	1	221*	176755	V-PACKING, leather, throat	2
206	24W619	CYLINDER, pump <i>includes retaining nuts 229</i>	1	222*	192710	V-PACKING, throat, V-Max™	3
207*	105444	BALL, sst, 0.3125 in.	1			UHMWPE, blue	
208*	195129	GLAND, male piston	1	223*	176749	V-PACKING, leather, piston	2
209*	180073	GLAND, female, piston	1	224*	192712	V-PACKING, piston, V-Max™	3
211*	15G234	GUIDE, piston	1			UHMWPE, blue	
212	239937	VALVE, piston (included with 201)	1	225	17C231	FITTING, pump, QD, 1/4 npt	1
213†	15C011	GUIDE, ball	1	229	NUTS, retaining, not sold separately		
215†	246429	KIT, seat, carbide <i>includes 213, 217 and 218</i>	1				
216	15B611	VALVE, intake housing	1				

* - Also included in Kit 244194

† - Also included in Kit 246429

Pump Installation

Pump installation includes securing the pump and connecting to the fluid inlet and outlet.

1. Connect outlet hose to pump.

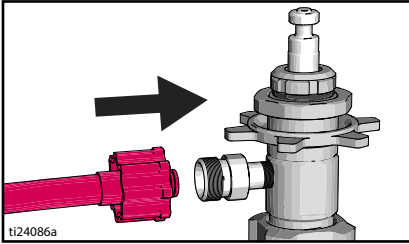

2. Move pump displacement rod up or down until it slides into the connecting rod when the pump is slid into the drive housing.

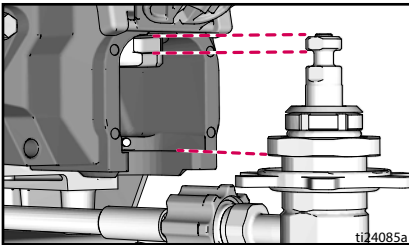

3. Slide pump all the way into drive housing.

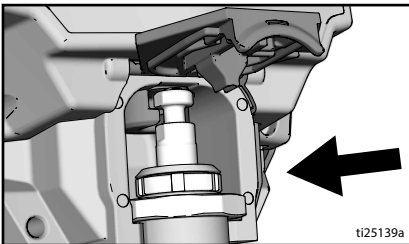

4. Close pump rod cover. Make certain that it is flush against drive housing.

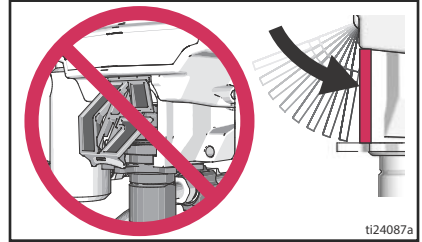

5. Use both hands to tighten pump retaining nut.

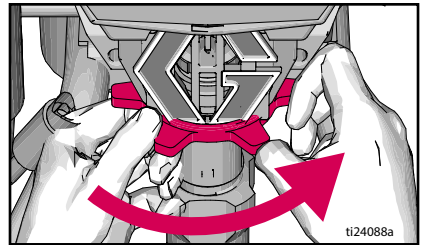

6. Use a hammer to turn pump retaining nut an additional 1/8 to 1/6th turn or 45° to 60°.

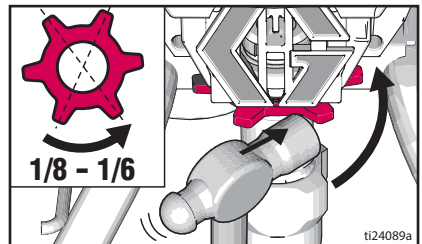

7. Install suction hose.

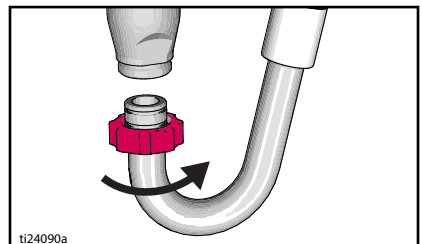

Technical Specifications

Technical Specifications

PC Displacement Pump		
	US	Metric
Maximum fluid working pressure	3300 psi	228 bar, 22.8 MPa
Inlet/Outlet Sizes		
Fluid inlet size	1.0 in. diameter	
Fluid outlet size	1/4 in.	
Wetted materials on all models	stainless steel, PTFE, leather, nylon, zinc-plated and nickel-plated carbon steel, tungsten carbide, chrome plating, UHMWPE, acetal, polyethylene, nylon	

Graco Standard Warranty

Graco warrants all equipment referenced in this document which is manufactured by Graco and bearing its name to be free from defects in material and workmanship on the date of sale to the original purchaser for use. With the exception of any special, extended, or limited warranty published by Graco, Graco will, for a period of twelve months from the date of sale, repair or replace any part of the equipment determined by Graco to be defective. This warranty applies only when the equipment is installed, operated and maintained in accordance with Graco's written recommendations.

This warranty does not cover, and Graco shall not be liable for general wear and tear, or any malfunction, damage or wear caused by faulty installation, misapplication, abrasion, corrosion, inadequate or improper maintenance, negligence, accident, tampering, or substitution of non-Graco component parts. Nor shall Graco be liable for malfunction, damage or wear caused by the incompatibility of Graco equipment with structures, accessories, equipment or materials not supplied by Graco, or the improper design, manufacture, installation, operation or maintenance of structures, accessories, equipment or materials not supplied by Graco.

This warranty is conditioned upon the prepaid return of the equipment claimed to be defective to an authorized Graco distributor for verification of the claimed defect. If the claimed defect is verified, Graco will repair or replace free of charge any defective parts. The equipment will be returned to the original purchaser transportation prepaid. If inspection of the equipment does not disclose any defect in material or workmanship, repairs will be made at a reasonable charge, which charges may include the costs of parts, labor, and transportation.

THIS WARRANTY IS EXCLUSIVE, AND IS IN LIEU OF ANY OTHER WARRANTIES, EXPRESS OR IMPLIED, INCLUDING BUT NOT LIMITED TO WARRANTY OF MERCHANTABILITY OR WARRANTY OF FITNESS FOR A PARTICULAR PURPOSE.

Graco's sole obligation and buyer's sole remedy for any breach of warranty shall be as set forth above. The buyer agrees that no other remedy (including, but not limited to, incidental or consequential damages for lost profits, lost sales, injury to person or property, or any other incidental or consequential loss) shall be available. Any action for breach of warranty must be brought within two (2) years of the date of sale.

GRACO MAKES NO WARRANTY, AND DISCLAIMS ALL IMPLIED WARRANTIES OF MERCHANTABILITY AND FITNESS FOR A PARTICULAR PURPOSE, IN CONNECTION WITH ACCESSORIES, EQUIPMENT, MATERIALS OR COMPONENTS SOLD BUT NOT MANUFACTURED BY GRACO. These items sold, but not manufactured by Graco (such as electric motors, switches, hose, etc.), are subject to the warranty, if any, of their manufacturer. Graco will provide purchaser with reasonable assistance in making any claim for breach of these warranties.

In no event will Graco be liable for indirect, incidental, special or consequential damages resulting from Graco supplying equipment hereunder, or the furnishing, performance, or use of any products or other goods sold hereto, whether due to a breach of contract, breach of warranty, the negligence of Graco, or otherwise.

FOR GRACO CANADA CUSTOMERS

The Parties acknowledge that they have required that the present document, as well as all documents, notices and legal proceedings entered into, given or instituted pursuant hereto or relating directly or indirectly hereto, be drawn up in English. Les parties reconnaissent avoir convenu que la rédaction du présente document sera en Anglais, ainsi que tous documents, avis et procédures judiciaires exécutés, donnés ou intentés, à la suite de ou en rapport, directement ou indirectement, avec les procédures concernées.

Graco Information

For the latest information about Graco products, visit www.graco.com.

For patent information, see www.graco.com/patents.

TO PLACE AN ORDER, contact your Graco distributor or call 1-800-690-2894 to identify the nearest distributor.

All written and visual data contained in this document reflects the latest product information available at the time of publication.

Graco reserves the right to make changes at any time without notice.

Original instructions. This manual contains English. MM 334599

Graco Headquarters: Minneapolis

International Offices: Belgium, China, Japan, Korea

GRACO INC. AND SUBSIDIARIES • P.O. BOX 1441 • MINNEAPOLIS MN 55440-1441 • USA

Copyright 2014, Graco Inc. All Graco manufacturing locations are registered to ISO 9001.

www.graco.com

Revision D, April 2016