

## Contractor II and FTx II Spray Guns

309639G

## Pistolets pulvérisateurs Contractor II et FTx II

## Pistolas de pulverización Contractor II y FTx II

## Pistolas de Pintura Contractor II e FTx II

- For applying architectural paints and coatings –
- Pour appliquer les peintures et les enduits architecturaux –
- Para aplicar las pinturas y las capas arquitectónicas –
- Para aplicar pinturas e revestimentos architectural –

Contractor II Models / Modèles / Modelos: 246220, 246221, 246222\*, 246538\*, 824987, 246434, 246224, 246225

FTx II Models / Modèles / Modelos: 246230, 246231, 246232\*, 246233, 246234, 246235, 246435, 246539\*, 246540

\*CE mark / CE marqué / CE marcado

3600 psi (248 bar, 24.8 MPa) Maximum Working Pressure

Pression de service maximum 3600 psi (252 bar, 25 MPa)

Presión máxima de funcionamiento de 3600 psi (252 bar, 25 MPa)

Pressão máxima de trabalho de 3600 psi (252 bar, 25 MPa)

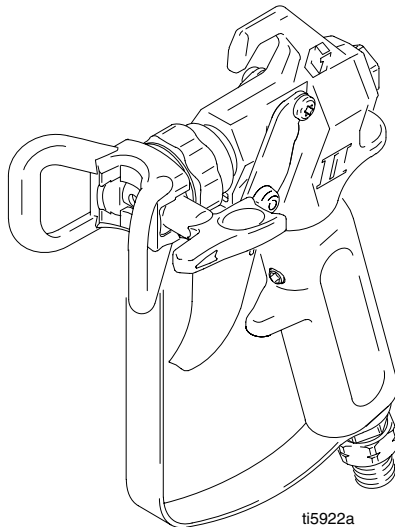

ti5922a

Model / Modèle / Modelo 246220

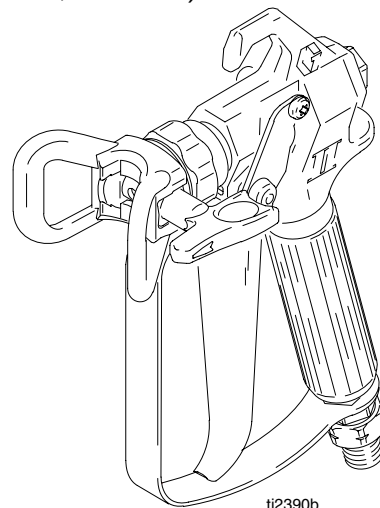





ti2390b

Model / Modèle / Modelo 246230

PROVEN QUALITY. LEADING TECHNOLOGY.





The following are general Warnings related to the safe setup, use, maintenance and repair of this equipment. Additional, more specific warnings may be found throughout the text of this manual where applicable.

## ! WARNING

	<p><b>FIRE AND EXPLOSION HAZARD</b></p> <p>Flammable fumes, such as solvent and paint fumes, in work area can ignite or explode. To help prevent fire and explosion:</p> <ul style="list-style-type: none"> <li>● Use equipment only in well ventilated area.</li> <li>● Eliminate all ignition sources; such as pilot lights, cigarettes, portable electric lamps, and plastic drop clothes (potential static arc).</li> <li>● Keep work area free of debris, including solvent, rags and gasoline.</li> <li>● Do not plug or unplug power cords or turn lights on or off when flammable fumes are present.</li> <li>● Ground equipment and conductive objects in work area. Read Grounding instructions.</li> <li>● If there is static sparking or you feel a shock, stop operating immediately. Do not use equipment until you identify and correct the problem.</li> </ul>
	<p><b>INJECTION HAZARD</b></p> <p>High pressure fluid from gun, hose leaks, or ruptured components will pierce skin. This may look like just a cut, but it is a serious injury that can result in amputation. <b>Get immediate medical attention.</b></p> <ul style="list-style-type: none"> <li>● Do not point gun at anyone or any part of the body.</li> <li>● Do not put your hand over the spray tip.</li> <li>● Do not stop or deflect leaks with your hand, body, glove, or rag.</li> <li>● Do not spray without tip guard and trigger guard installed.</li> <li>● Engage trigger lock when not spraying.</li> <li>● Follow Pressure Relief Procedure in this manual, when you stop spraying and before cleaning, checking or servicing equipment.</li> </ul>
 <p>INSTRUCTIONS</p>	<p><b>EQUIPMENT MISUSE HAZARD</b></p> <p>Misuse can cause death or serious injury.</p> <ul style="list-style-type: none"> <li>● Do not exceed the maximum working pressure or temperature rating of the lowest rated system component. Read <b>Technical Data</b> in all equipment manuals.</li> <li>● Use fluids and solvents that are compatible with equipment wetted parts. Read <b>Technical Data</b> in all equipment manuals. Read fluid and solvent manufacturer's warnings.</li> <li>● Check equipment daily. Repair or replace worn or damaged parts immediately.</li> <li>● Do not alter or modify equipment.</li> <li>● Use equipment only for its intended purpose. Call your Graco distributor for information.</li> <li>● Route hoses and cables away from traffic areas, sharp edges, moving parts and hot surfaces.</li> <li>● Do not use hoses to pull equipment.</li> <li>● Keep children and animals away from work area.</li> <li>● Comply with all applicable safety regulations.</li> </ul>
	<p><b>PRESSURIZED ALUMINUM PARTS HAZARD</b></p> <p>Do not use 1,1,1-trichloroethane, methylene chloride, other halogenated hydrocarbon solvents or fluids containing such solvents in this equipment. Such use could result in a serious chemical reaction, with the possibility of explosion, which could cause death, serious injury and/or substantial property damage.</p>





Ce qui suit sont des avertissements généraux liés à l'installation, à l'utilisation, à l'entretien et à la réparation sûrs de cet équipement. Des avertissements additionnels et plus spécifiques peuvent être trouvés dans tout le texte de ce manuel là où applicables.

## MISE EN GARDE

	<p><b>DANGER D'INCENDIE ET D'EXPLOSION</b></p> <p>Les vapeurs inflammables, vapeurs de solvant et de peinture par exemple, sur le lieu de travail peuvent s'enflammer ou exploser. Pour prévenir un incendie ou une explosion:</p> <ul style="list-style-type: none"> <li>• N'utiliser I☒</li> <li>• Supprimer toutes les source de feu, telles que les veilleuses, cigarettes, lampes électriques portatives et bâches plastique (risque de décharge d☒)</li> <li>• Veiller à débarrasser la zone de travail de tout résidu, comme les solvants, les chiffons et l'essence.</li> <li>• Ne pas brancher ni débrancher de cordons d'alimentation électrique ni allumer ou éteindre la lumière en présence de vapeurs inflammables.</li> <li>• Raccorder le matériel et les objets conducteurs se trouvant dans la zone de travail à la terre.</li> <li>• Si l'on remarque la moindre étincelle d'électricité statique ou si l'on ressent une décharge électrique, arrêter le travail immédia.</li> </ul>
	<p><b>DANGER D'INJECTION</b></p> <p>Le produit s'échappant à haute pression du pistolet, d'une fuite sur le flexible ou d'un composant défectueux risque de transpercer la peau. La blessure peut avoir l'aspect d'une simple coupure, mais il s'agit en fait d'une blessure sérieuse pouvant entraîner une amputation. Consulter immédiatement un médecin.</p> <ul style="list-style-type: none"> <li>• Ne pas diriger le pistolet sur quelqu'un ou une partie quelconque du corps.</li> <li>• Ne pas mettre la main devant la buse de projection.</li> <li>• Ne jamais colmater ou dévier les fuites avec la main, le corps, un gant ou un chiffon.</li> <li>• Ne pas pulvériser sans garde-buse ni sous-garde.</li> <li>• Verrouiller la gâchette à chaque arrêt de la pulvérisation.</li> <li>• Observer la Procédure de décompression de ce manuel à chaque arrêt de la pulvérisation et avant tout nettoyage, contrôle ou entretien du matériel.</li> </ul>
 <p>INSTRUCTIONS</p>	<p><b>RISQUE D'ABUS D'ÉQUIPEMENT</b></p> <p>L'abus peut causer la mort ou des dommages sérieux.</p> <ul style="list-style-type: none"> <li>• N'excédez pas l'estimation maximum de pression ou de température d'utilisation du plus bas composant évalué de système. Lisez les données techniques en tous les manuels d'équipement.</li> <li>• Employez les fluides et les dissolvants qui sont compatibles avec les pièces mouillées par équipement. Lisez les données techniques en tous les manuels d'équipement. Lisez les avertissements liquides et dissolvants de manufacturer's.</li> <li>• Vérifiez le journal d'équipement. Réparez ou remplacez les pièces usées ou endommagées immédiatement.</li> <li>• Ne changez pas ou ne modifiez pas l'équipement.</li> <li>• Utilisez l'équipement seulement pour son but prévu. Appelez votre distributeur de Graco pour information.</li> <li>• Conduisez les tuyaux et les câbles loin des chaussées, des bords pointus, des pièces mobiles et des surfaces chaudes.</li> <li>• N'utilisez pas les tuyaux pour tirer l'équipement.</li> <li>• Maintenez les enfants et les animaux partis de la zone de travail.</li> <li>• Conformez-vous à tous les règlements applicables de sûreté.</li> </ul>
	<p><b>RISQUES LIES AUX PIECES EN ALUMINIUM SOUS PRESSION.</b></p> <p>N☒ ni 1,1,1-trichloréthane, ni chlorure de méthylène, ni solvants à base d'hydrocarbures halogénés, ni produits renfermant de tels solvants dans un appareil sous pression en aluminium. L'utilisation de ces produit peut déclencher une violente réaction chimique et une casse du matériel et provoquer ainsi de graves dommages corporels et matériels pouvant entraîner la mort.</p>



Los siguientes son advertencias generales relacionadas con la disposición, el uso, el mantenimiento y la reparación seguros de este equipo. Las advertencias adicionales, más específicas se pueden encontrar a través del texto de este manual donde aplicables.

## **ADVERTENCIA**

	<p><b>PELIGRO DE INCENDIOS Y EXPLOSIONES</b></p> <p>Vapores inflamables, como los vapores de disolvente o de pintura en la zona de trabajo pueden incendiarse o explotar. Para evitar un incendio o explosión:</p> <ul style="list-style-type: none"> <li>● Utilice el equipo únicamente en áreas bien ventiladas.</li> <li>● Elimine toda fuente de ignición, tales como las luces piloto, los cigarrillos, las linternas eléctricas y las cubiertas de plástico (arcos estáticos potenciales).</li> <li>● Mantenga limpia la zona de trabajo, sin disolventes, trapos o gasolina.</li> <li>● No enchufe ni desenchufe cables de alimentación ni apague ni encienda las luces en el área de pulverización.</li> <li>● Conecte a tierra el equipo y los objetos conductores eléctricamente de la zona de trabajo.</li> <li>● Si se aprecia la formación de electricidad estática durante el uso de este equipo, deje de trabajar inmediatamente. No utilice el sistema hasta haber identificado y corregido el problema.</li> </ul>
	<p><b>PELIGRO DE INYECCIÓN</b></p> <p>El fluido a alta presión procedente de la pistola, fugas de la manguera o componentes rotos penetrarán en la piel. La inyección del líquido puede tener la apariencia de un simple corte, pero se trata de una herida grave que puede conducir a la amputación. Consiga atención médica inmediatamente.</p> <ul style="list-style-type: none"> <li>● No coloque la mano o los dedos sobre la boquilla de pulverización, ni apunte la pistola hacia nadie ni ninguna parte del cuerpo.</li> <li>● No coloque la mano sobre la boquilla de pulverización.</li> <li>● No intente bloquear ni desviar posibles fugas con la mano, el cuerpo, los guantes o con un trapo.</li> <li>● Nunca pulverice sin la protección de la boquilla y el seguro del gatillo.</li> <li>● Enganche el seguro del gatillo cuando no esté pulverizando.</li> <li>● Siga el Procedimiento de descompresión de este manual, cuando deje de pulverizar y antes de limpiar, revisar o reparar el equipo.</li> </ul>
 <small>INSTRUCTIONS</small>	<p><b>PELIGRO DEL USO ERRÓNEO DEL EQUIPO</b></p> <p>El uso erróneo puede causar muerte o lesión seria.</p> <ul style="list-style-type: none"> <li>● No exceda el grado máximo de la presión o de la temperatura de funcionamiento del componente clasificado más bajo del sistema. Lea los datos técnicos en todos los manuales del equipo.</li> <li>● Utilice los líquidos y los solventes que son compatibles con las piezas mojadas equipo. Lea los datos técnicos en todos los manuales del equipo. Lea las advertencias flúidas y solventes de manufacturer's.</li> <li>● Compruebe el diario del equipo. Repare o sustituya las piezas gastadas o dañadas inmediatamente.</li> <li>● No altere ni modifique el equipo.</li> <li>● Utilice el equipo solamente para su propósito previsto. Llame su distribuidor de Graco para la información.</li> <li>● Encamine las mangueras y los cables lejos de áreas de tráfico, de bordes agudos, de piezas móviles y de superficies calientes.</li> <li>● No utilice las mangueras para tirar del equipo.</li> <li>● Mantenga los niños y los animales ausentes de área de trabajo.</li> <li>● Confórmese con todas las regulaciones aplicables de seguridad.</li> </ul>
	<p><b>PELIGRO DE PIEZAS DE ALUMINIO PRESURIZADAS</b></p> <p>No utilice 1,1,1 tricloroetano, cloruro de metileno y otros disolventes de hidrocarburos halogenados o productos que contengan dichos disolventes con equipos de aluminio presurizados. Esas sustancias podrían provocar peligrosas reacciones químicas y ruptura del equipo, y causar la muerte, lesiones graves y daños materiales.</p>

Os seguintes são avisos gerais relacionados à instalação, ao uso, à manutenção e ao reparo seguros deste equipamento. Os avisos adicionais, mais específicos podem ser encontrados durante todo o texto deste manual onde aplicáveis.

## **ADVERTÊNCIA**

	<p><b>PERIGO DE INCÊNDIO E EXPLOSÃO</b></p> <p>Os vapores inflamáveis na área de trabalho, tais como os provenientes de solventes e tintas, podem inflamar-se ou explodir. Para ajudar a evitar incêndios e explosões:</p> <ul style="list-style-type: none"> <li>• Utilize o equipamento apenas em áreas bem ventiladas.</li> <li>• Elimine todas as fontes de ignição, como, por exemplo, luzes piloto, cigarros, luzes eléctricas portáteis e plásticos de protecção (potencial arco estático).</li> <li>• Mantenha a área de trabalho sem detritos, incluindo solvente, panos e gasolina.</li> <li>• Não ligue nem desligue cabos de alimentação ou luzes na presença de vapores inflamáveis.</li> <li>• Ligue o equipamento e os objectos condutores presentes na área de trabalho à terra.</li> <li>• Se ocorrerem faíscas de estática ou se sentir um choque eléctrico, interrompa a utilização imediatamente. Não utilize o equipamento até identificar e eliminar o problema.</li> </ul>
	<p><b>PERIGO DE INJEÇÃO</b></p> <p>O produto a alta pressão proveniente da pistola, fugas nos tubos flexíveis ou componentes danificados poderá provocar lesões na pele. As lesões podem ter o aspecto de um simples corte, porém, constituem ferimentos graves capazes de conduzir à amputação. Obtenha aconselhamento médico imediato.</p> <ul style="list-style-type: none"> <li>• Não aponte a pistola a ninguém nem a nenhuma parte do corpo.</li> <li>• Não coloque as mãos sobre o bico.</li> <li>• Não tente interromper ou desviar fugas com a mão, o corpo, uma luva ou um pano.</li> <li>• Não comece a pintar sem que o protector do bico e o dispositivo de segurança do gatilho estejam instalados.</li> <li>• Engate o dispositivo de segurança do gatilho quando não estiver a pintar.</li> <li>• Siga o Procedimento de Descompressão neste manual, quando parar de pintar e antes de dar início aos procedimentos de limpeza, verificação ou manutenção. INJECTION HAZARD</li> </ul>
 <p>INSTRUCTIONS</p>	<p><b>PERIGO DO EMPREGO ERRADO DO EQUIPAMENTO</b></p> <p>O emprego errado pode causar a morte ou ferimento sério.</p> <ul style="list-style-type: none"> <li>• Não exceda a avaliação máxima da pressão ou da temperatura de funcionamento do componente rated o mais baixo do sistema. Leia dados técnicos em todos os manuais do equipamento.</li> <li>• Use os líquidos e os solventes que são compatíveis com as peças molhadas equipamento. Leia dados técnicos em todos os manuais do equipamento. Leia os avisos fluidos e solventes de manufacturer's.</li> <li>• Verifique o diário do equipamento. Repare ou substitua as peças gastas ou danificadas imediatamente.</li> <li>• Não altere nem não modifique o equipamento.</li> <li>• Use o equipamento somente para sua finalidade pretendida. Chame seu distribuidor de Graco para a informação.</li> <li>• Distribua mangueiras e cabos away das áreas de tráfego, das bordas afiadas, das peças moventes e das superfícies quentes.</li> <li>• Não use mangueiras puxar o equipamento.</li> <li>• Mantenha as crianças e os animais ausentes da área de trabalho.</li> <li>• Comply com todos os regulamentos aplicáveis de segurança.</li> </ul>
	<p><b>PERIGO DE PEÇAS DE ALUMÍNIO PRESSURIZADO</b></p> <p>Não utilize 1,1,1-tricloroetano, cloreto de metileno, outros solventes de hidrocarboneto halogenado ou produtos que contenham os solventes referidos em equipamento de alumínio pressurizado. A utilização dos produtos referidos pode provocar reacções químicas violentas e avaria do equipamento e resultar em morte, lesões graves e danos em bens.</p>

# IMPORTANT / IMPORTANTE

**TRIGGER LOCK POSITIONS**  
**POSITIONS DE VERROUILLAGE**  
**DE LA GACHETTE**  
**POSICIONES DE BLOQUEO DEL**  
**GATILLO**  
**POSIÇÕES DE BLOQUEIO DO**  
**GATILHO**

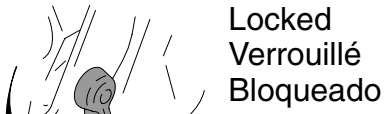

Locked  
Verrouillé  
Bloqueado

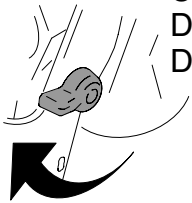

Unlocked  
Déverrouillé  
Desbloqueado

**RAC X TIP CAN ONLY BE INSERTED ONE WAY !**  
**LA BUSE RAC X NE PEUT SE MONTER QUE DANS UN SENS !**  
**¡LA BOQUILLA RAC X SÓLO PUEDE COLOCARSE DE UNA FORMA!**  
**O BICO RAC X SÓ PODE SER INSERIDO DE UMA MANEIRA!**

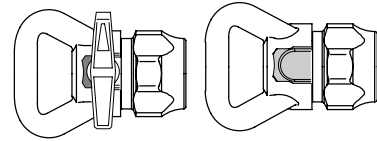
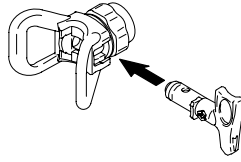

Tip can only be inserted and removed by aligning locking tab on tip and guard slot properly.

Le seul moyen de monter et démonter la buse est d'aligner la patte de verrouillage sur l'orifice de la buse et de la garde.

La boquilla sólo puede colocarse y desmontarse alineando correctamente la lengüeta de bloqueo y la ranura de la protección.

O bico só pode ser inserido e removido alinhando devidamente a patilha de bloqueio do bico e a ranhura do protector.

## PRESSURE RELIEF / DÉCOMPRESSION / DESCOMPRESIÓN / ALIVIO DE PRESSÃO



Follow 1–7 when you stop spraying.

Effectuer les opérations 1–7 lors d'un arrêt de la pulvérisation.

Cuando deje de pulverizar, siga los pasos 1–7.

Siga os passos de 1–7 quando parar de pulverizar.

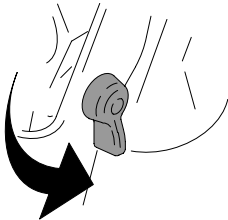

1. Turn sprayer OFF. Set trigger lock.  
Mette le pulvérisateur sur ARRET. Verrouiller la gâchette.  
  
Apague el pulverizador. Fije el bloqueo del gatillo.  
  
Desligue o equipamento. Aplique o fecho do gatilho.

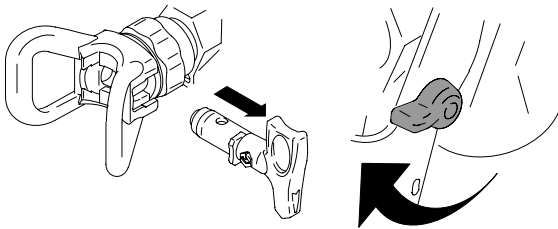

2. Remove tip. Remove trigger lock.  
  
Enlever la buse. Déverrouiller la gâchette.  
  
Desmonte la boquilla. Suelte el bloqueo del gatillo.  
  
Retire o bico. Retire o fecho do gatilho.

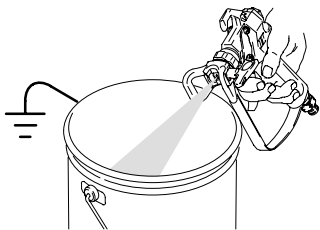

3. Trigger gun into grounded metal bucket.  
  
Actionner le pistolet en le tenant dans un seau métallique mis à la terre  
  
Dispare la pistola hacia el interior de un cubo metálico conectado a tierra.  
  
Accione a pistola para um balde metálico ligado à terra.

# ALIGN SPRAY / ALIGNER LE JET / ALINEAR PULVERIZACIÓN / DIRIGIR O LEQUE

## ! WARNING



Relieve Pressure, page 6. Read Injection Hazard Warning, page 2.

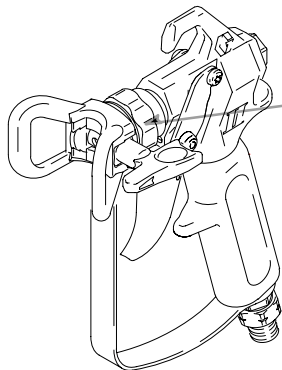

1. Loosen tip guard retaining nut.

Desserrer l'écrou de fixation du garde-buse.

Afloje la tuerca de retención de la protección de la boquilla.

Desaperte a porca de retenção da protecção do bico.

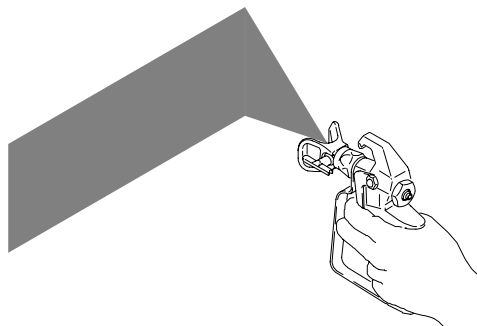

2. To spray a horizontal pattern, turn tip guard horizontally.

Pour obtenir un jet horizontal, mettre le garde-buse à l'horizontale.

Para conseguir un chorro de pulverización horizontal, gire la protección de la boquilla hasta la posición horizontal.

Posicione o protector do bico horizontalmente, caso pretenda um leque horizontal.

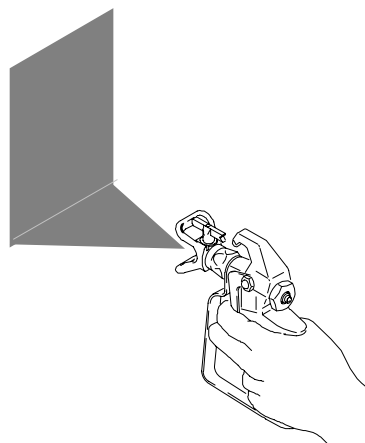

3. To spray a vertical pattern, turn tip guard vertically.

Pour obtenir un jet vertical, mettre le garde-buse à la verticale.

Para conseguir un chorro de pulverización vertical, gire la protección de la boquilla hasta la posición vertical.

Posicione o protector do bico verticalmente, caso pretenda um leque vertical.

# ADJUST SPRAY / RÉGLER LE JET / AJUSTAR PULVERIZACIÓN / REGULAR A PULVERIZAÇÃO

## ! WARNING



Relieve Pressure, page 6. Read Fire and Explosion Hazard and Injection Hazard Warning, pages 2.

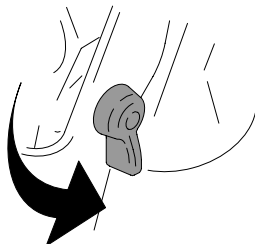

1. Set trigger lock.

Verrouiller la gâchette.

Fije el bloqueo del gatillo.

Aplique o fecho do gatilho.

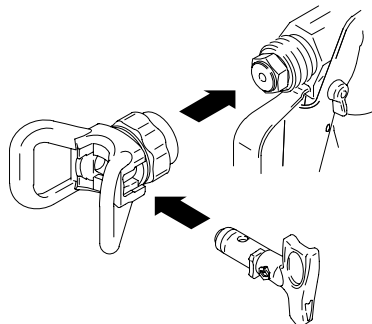

2. Install tip and guard.

Monter la buse et la garde.

Instale la boquilla y la protección.

Instale o bico e a respectiva protecção.

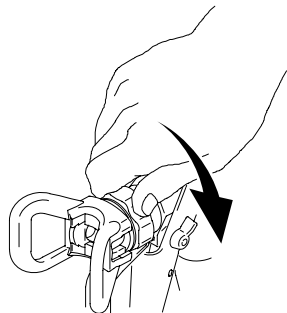

3. Tighten retaining nut.

Resserrer l'écrou de retenue.

Apretar la tuerca de retención.

Aperte a porca de retenção.

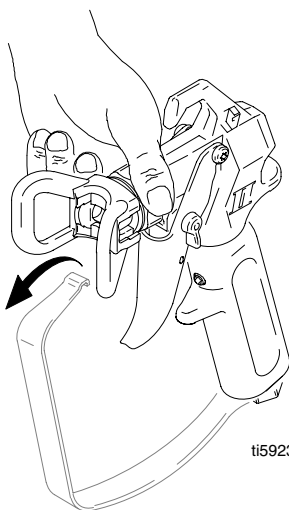

NOTE: Disconnecting trigger guard from body beneath diffuser provides unobstructed access to the nut for tightening.

NB: en retirant le garde-buse du corps en dessous du diffuseur, on dégage l'accès à l'écrou pour le serrer.

NOTA: Si desconecta la protección del gatillo por debajo del difusor podrá apretar la tuerca.

NOTA: ao separar o protector do gatilho do corpo sob o difusor, é providenciado livre acesso à porca, para apertar.

ti5923a



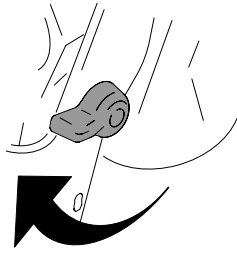

4. Remove trigger lock.

Déverrouiller la gâchette.

Suelte el bloqueo del gatillo.

Retire o fecho do gatilho.

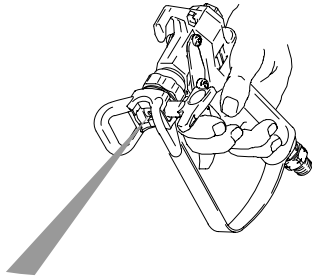

5. Trigger gun.

Actionner le pistolet.

Dispare la pistola.

Accione a pistola.

---

6. Hold gun perpendicular and approximately 12 in. (304 mm) from surface. Move gun first, then pull gun trigger to spray.

Tenir le pistolet perpendiculairement à la surface à peindre et à env. 12 in. (304 mm) de celle-ci. Commencer par déplacer le pistolet, puis appuyer sur la gâchette pour pulvériser.

Sujete la pistola perpendicularmente y a una distancia de la superficie de unos 304 mm (12 pulgadas). Mueva primero la pistola, y después apriete el gatillo para comenzar a pulverizar.

Segure a pistola na perpendicular e a cerca de 304 mm da superfície. Movimento primeiro a pistola, accionando depois o gatilho para pintar.

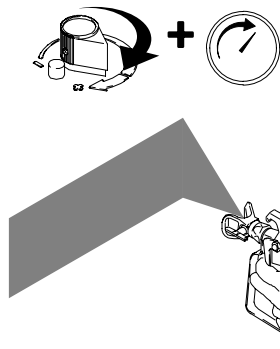
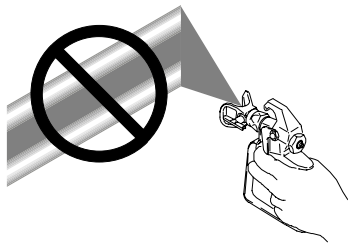

7. Slowly increase the pump pressure until coverage is even and uniform.

Augmenter lentement la pression de la pompe jusqu'à ce que la couche de couverture soit régulière et uniforme.

Aumente lentamente la presión de la bomba hasta conseguir una cobertura uniforme.

Aumente lentamente a pressão da bomba, até a cobertura estar uniforme.

# CLEAR CLOG / DÉBOUCHER LA BUSE / ELIMINAR OBSTRUCCIÓN / ELIMINAR A OBSTRUÇÃO

## **WARNING**



Relieve Pressure, page 6. Read Injection Hazard Warning, page 2.

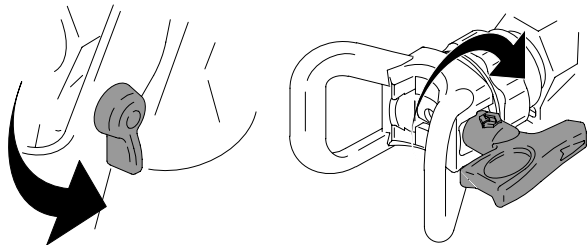

1. Set trigger lock. Rotate tip 180°.

Verrouiller la gâchette. Tourner la buse de 180°.

Fije el bloqueo del gatillo. Gire la boquilla 180°.

Aplique o fecho do gatilho. Rode o bico 180°.

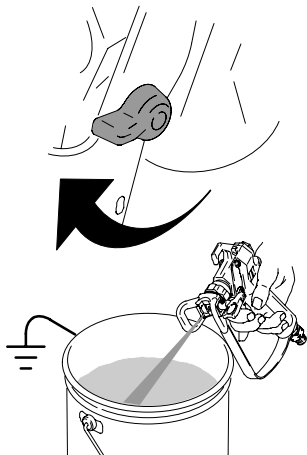

2. Remove trigger lock. Trigger gun into pail or onto ground to remove clog.

Déverrouiller la gâchette. Actionner le pistolet dans un seau ou au-dessus du sol pour le déboucher.

Suelte el bloqueo del gatillo. Dispare la pistola hacia el interior de un bidón para eliminar la obstrucción.

Retire o fecho do gatilho. Accione a pistola para o balde ou para o chão, para remover a obstrução.

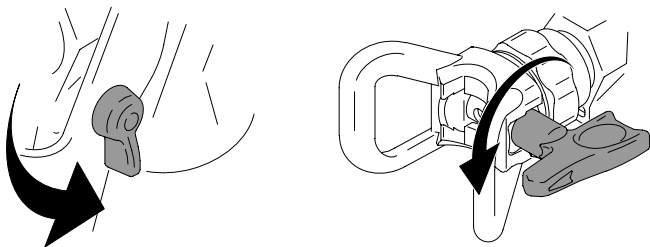

3. Set trigger lock. Rotate tip 180°. Continue to spray.

Verrouiller la gâchette. Tourner la buse de 180°.

Fije el bloqueo del gatillo. Gire la boquilla 180°.

Aplique o fecho do gatilho. Rode o bico 180°.

# REPLACE NEEDLE / REMPLACER LE POINTEAU / REEMPLAZAR AGUJA / SUBSTITUIR AGULHA

## ⚠ WARNING



Relieve Pressure, page 6. Read Injection Hazard Warning, page 2.

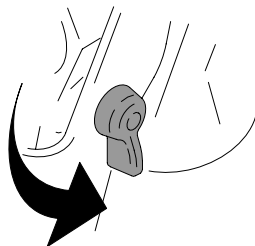

1. Set trigger lock.

Verrouiller la gâchette.

Fije el bloqueo del gatillo.

Aplique o fecho do gatilho.

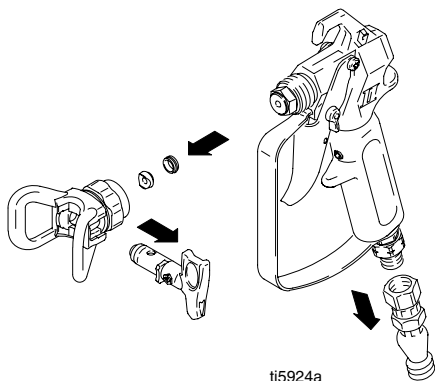

2. Remove tip and guard and disconnect gun from fluid hose.

Démonter la buse et la garde, puis débrancher le flexible produit sur le pistolet.

Retire la boquilla y la protección y desconecte la pistola de la manguera de fluido.

Retire o bico e a protecção e desligue a mangueira da pistola.

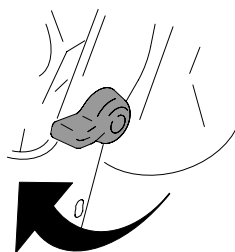

3. Release trigger lock.

Déverrouiller la gâchette.

Suelte el bloqueo del gatillo.

Solte o fecho do gatilho.

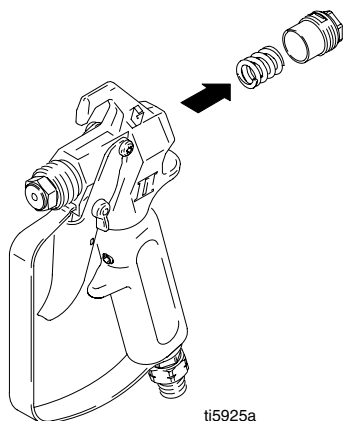

4. Remove end cap and spring from inside gun.

Sortir le chapeau d'extrémité et le ressort du pistolet.

Desmonte el casquillo de extremo y el muelle del interior de la pistola.

Retire a tampa da extremidade e a mola do interior da pistola.

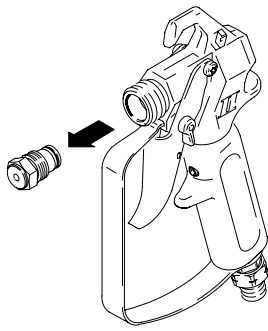

ti5926a

5. Remove diffuser.

Enlever le diffuseur.

Desmonte el difusor.

Retire o difusor.

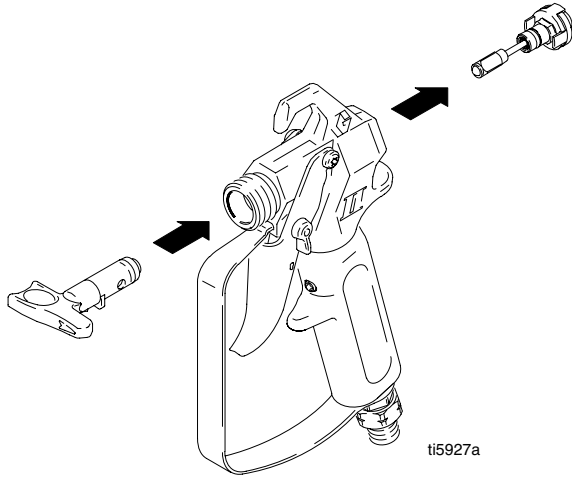

ti5927a

6. Remove needle assembly by pushing it through the gun body from the front, out the back.

Démonter le pointeau en le poussant par devant hors du corps du pistolet.

Desmonte el conjunto de la aguja empujándolo a través del cuerpo de la pistola desde la parte delantera hacia la parte trasera.

Retire a agulha, empurrando-a ao longo do corpo da pistola, da frente para trás.

**HINT:** Use the barrel of the RAC tip to push needle from front through gun body.

**CONSEIL:** Se servir de la tige de la buse RAC pour pousser le pointeau par devant et le chasser du corps du pistolet.

**CONSEJO:** Utilice el cilindro de la boquilla RAC para empujar la aguja desde la parte delantera a través del cuerpo de la pistola.

**SUGESTÃO:** use o barril do bico RAC para empurrar a agulha ao longo do corpo da pistola, a partir da frente.

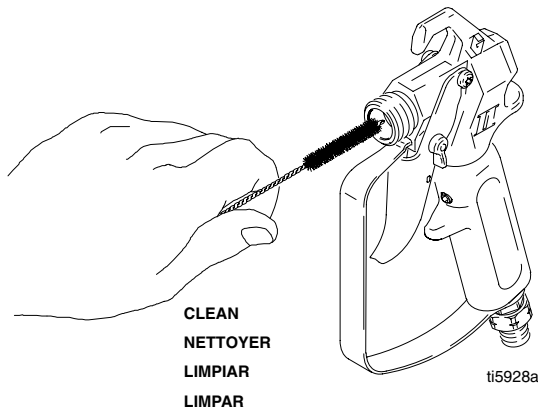

ti5928a

7. Clean internal passages of gun.

Nettoyer les conduits intérieurs du pistolet.

Limpe los conductos internos de la pistola.

Limpe as passagens internas da pistola.

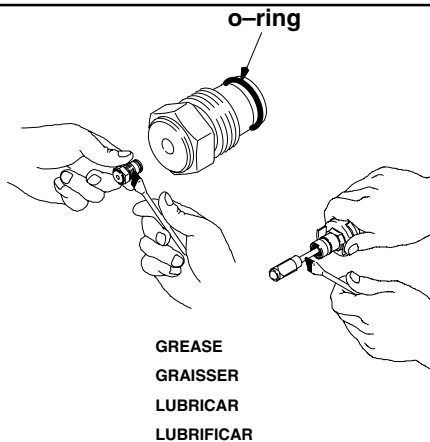

8. Grease o-rings on diffuser and new needle using a *nonsilicon* grease.

Graisser les joints toriques du nouveau pointeau avec une graisse *sans silicone*.

Engrase las juntas tóricas de la nueva aguja utilizando una grasa *sin silicona*.

Lubrifique os vedantes da nova agulha, utilizando uma massa lubrificante *sem silicone*.

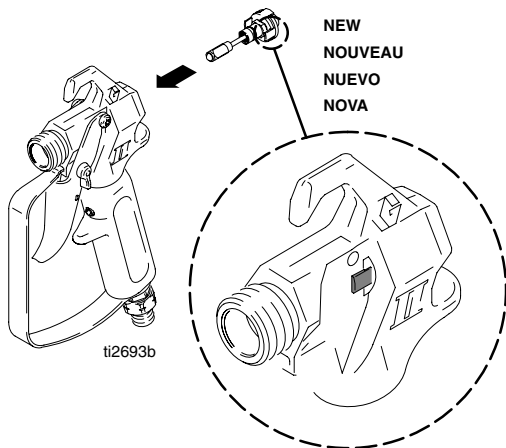

9. Insert new needle into gun as shown.

Enfoncer le nouveau pointeau dans le pistolet.

Introduzca la nueva aguja en la pistola.

Introduza a nova agulha na pistola.

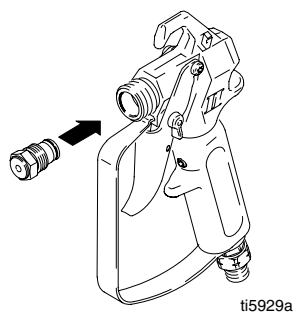

10. Install diffuser. Tighten to 120–130 in. lbs.

Monter le diffuseur. Serrer à 120–130 in. lbs.

Instale el difusor. Apriete a un par de 120–130 in. lbs.

Instale o difusor. Aperte 120–130 lbs. pol.

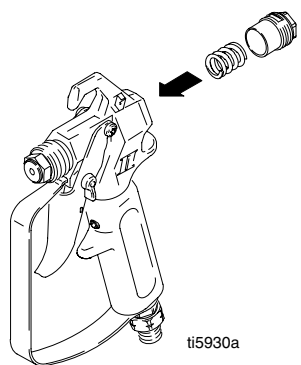

11. Install spring and end cap. Tighten to 28–32 in. lbs.

Mettre le ressort et le chapeau en place. Serrer à 28-32 in. lbs.

Instale el muelle y la tapa del extremo. Apriete a un par de 28–32 in. lbs.

Instale a mola e a tampa da extremidade. Aperte 28–32 lbs. pol.

# Cleaning Filter / Nettoyage du filtre / Limpieza del filtro / Limpeza do filtro

## ⚠ WARNING



Relieve Pressure, page 6. Read Injection Hazard Warning, page 3.



1. Set trigger lock.  
Verrouiller la gâchette.  
Fije el bloqueo del gatillo.  
Aplique o fecho do gatilho.

### Contractor II Gun

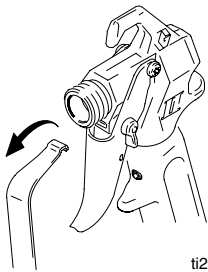

ti2583c

### FTX II Gun

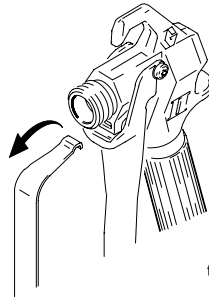

ti4308a

2. Disconnect trigger guard from gun body beneath diffuser by pushing up on guard hook and pulling it out of notch.

Désolidariser la sous-garde du corps du pistolet en dessous du diffuseur en poussant la garde vers le haut et en la décrochant.

Desconecte la protección del gatillo del cuerpo de la pistola, por debajo del difusor, empujando hacia arriba el gancho de la protección y sacándola por la ranura.

Separe o protector do gatilho do corpo da pistola, sob o difusor, fazendo pressão para cima no encaixe do protector e retirando-o do entalhe.

3. Unscrew handle from gun housing or use the trigger guard beneath the gun handle as a wrench to loosen the nut.

Dévissez la poignée du logement de pistolet ou employez la garde de déclenchement sous la poignée de pistolet comme clé pour détacher l'écrou.

Desatornille la manija de la cubierta del arma o utilice a protector del disparador debajo de la manija del arma como llave para aflojar la tuerca.

Desaparafuse o punho da carcaça do injetor ou use o protetor do disparador abaixo do punho do injetor como uma chave afrouxar a porca.

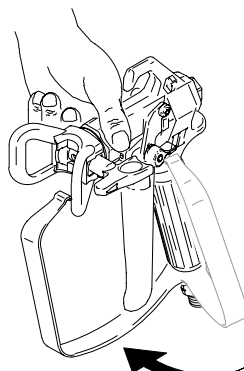
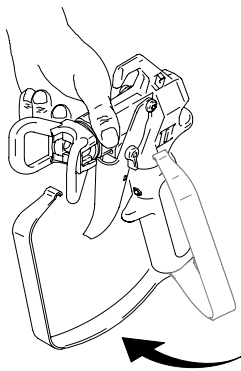
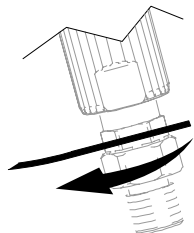
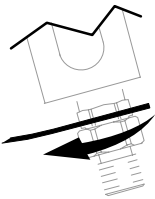
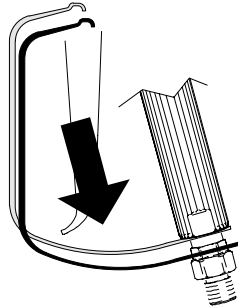
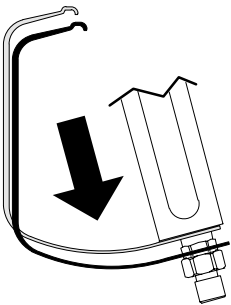

**LOOSEN / DESSERRER /  
AFLOJE / DESAPERTE**

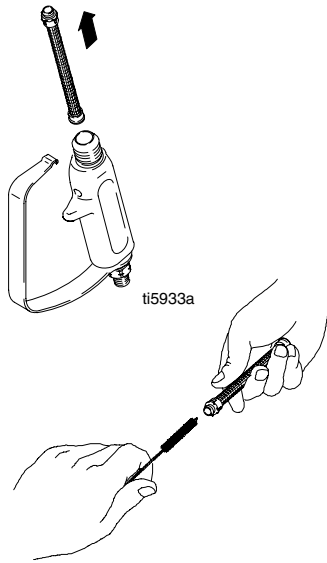

4. Remove and clean filter. A soft brush can be used to loosen and remove debris.

NOTE: Filter is removed from top of gun handle.

Démonter le filtre. Utiliser une brosse douce pour enlever les impuretés.

REMARQUE: sortir le filtre par le haut de la poignée.

Desmonte el filtro. Se puede utilizar un cepillo suave para soltar y eliminar la suciedad.

NOTA: El filtro se desmonta por la parte superior de la empuñadura de la pistola.

Retire o filtro. Pode ser usada uma escova macia para soltar e remover o lixo.

NOTA: o filtro é retirado a partir do topo do punho da pistola.

5. Insert filter in handle.

NOTE: Filter is reinserted in opening on top of gun handle.

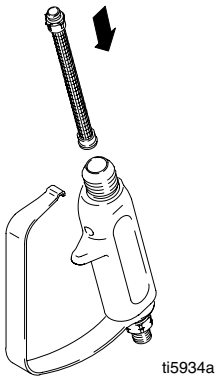

Réintroduire le filtre dans la poignée.

REMARQUE: Introduire le filtre par l'ouverture située sur le dessus de la poignée.

Introduzca el filtro en la empuñadura.

NOTA: El filtro se introduce por la abertura de la parte superior de la empuñadura de la pistola.

Insira o filtro no punho.

NOTA: o filtro é novamente inserido na abertura no topo do punho da pistola.

6. Attach handle to gun head.

Attachez la poignée à la tête de pistolet.

Una la manija a la cabeza del arma.

Una o punho à cabeça do injetor.

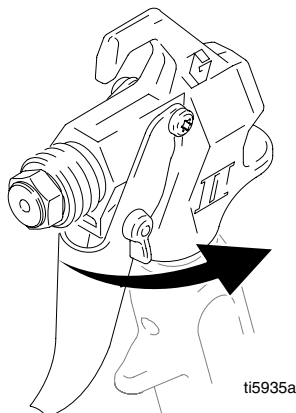

**TIGHTEN  
RESSERRER  
APRIETE  
APERTE**

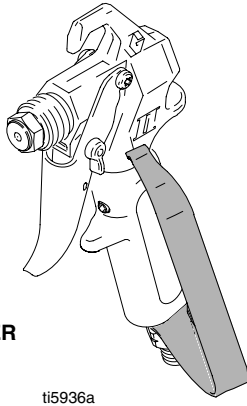

7. Tighten handle by hand until it is firmly seated in fluid head or use trigger guard to tighten nut.

Serrez la poignée à la main jusqu'à ce qu'elle soit fermement posée dans la tête liquide ou employez la garde de déclenchement pour serrer l'écrou.

Apriete la manija a mano hasta que se asienta firmemente en la cabeza flúida o utilice a protector del disparador para apretar la tuerca.

Aperte o punho pela mão até que esteja assentada firmemente na cabeça fluida ou use o protetor do disparador apertar a porca.

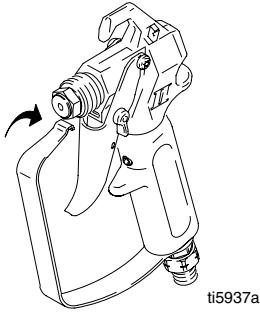

8. Reattach trigger guard to gun.

Refixer la sous-garde sur le pistolet.

Vuelva a colocar la protección del gatillo en la pistola.

Volte a inserir o protetor do gatilho na pistola.

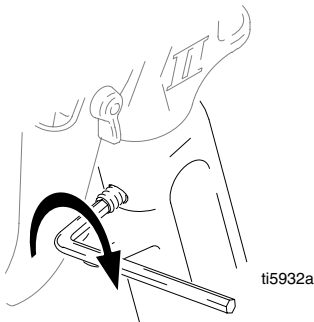

**NOTE: For the Contractor II model only:** To adjust alignment of the handle to the fluid head, loosen set screw in gun handle with an allen wrench. Turn handle to adjust alignment. Retighten set screw.

**NOTE :** Pour le modèle de l'entrepreneur II seulement : Pour ajuster l'alignement de la poignée sur la tête liquide, détachez la vis de réglage dans la poignée de pistolet avec une clé mâle. Tournez la poignée pour ajuster l'alignement. Resserez la vis de réglage.

**NOTA:** Para el modelo del contratista II solamente: Para ajustar la alineación de la manija a la cabeza flúida, afloje el tornillo de presión en manija del arma con una llave Allen. Dé vuelta a la manija para ajustar la alineación. Vuelva a apretar el tornillo de presión.

**NOTA:** Para o modelo do contratante II somente: Para ajustar o alinhamento do punho à cabeça fluida, afrouxe o parafuso de fixação no punho do injetor com uma chave de Allen. Gire o punho para ajustar o alinhamento. Reaperte o parafuso de fixação.



# Parts Drawing / Pièces / Diagrama de piezas / Desenho das peças

Contractor Gun Models: / Modèles de pistolets Contractor:  
Modelos de pistola Contractor: / Modelos de Pistola Contractor:  
246220, 246221, 246222, 246224, 246225, 246434, 246538, 824987

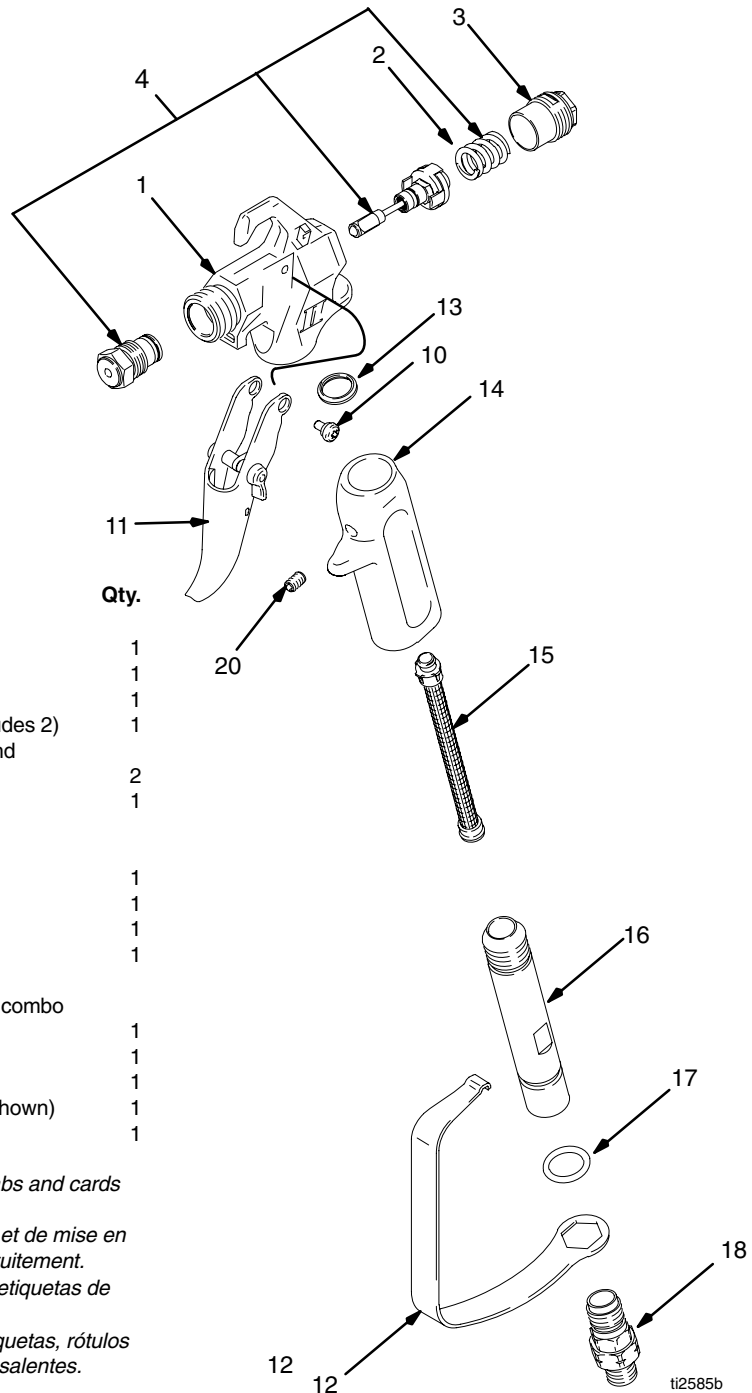

Ref. No.	Part No.	Description	Qty.
1	15B569	HOUSING	1
2	15D917	SPRING, compression	1
3	15B549	NUT, end	1
4	287031	KIT, needle, repair, (includes 2)	1
10	117602	SCREW, shoulder, pan hd (included with 11)	2
11	287102	TRIGGER, 2-finger	1
	287103	TRIGGER, 4-finger	
	287104	TRIGGER, 2-finger, CE	
12	15B579	GUARD, trigger	1
13	179733	SEAL, sleeve	1
14	15B580	HANDLE	1
15	287032	FILTER, 60 mesh	1
	287033	FILTER, 100 mesh	
	287034	FILTER, 60 & 100 mesh combo	
16	15B583	TUBE, handle	1
17	15B958	O-RING, packing	1
18	287099	SWIVEL	1
19▲	222385	WARNING CARD (not shown)	1
20	100002	SCREW, set	1

▲ Replacement Danger and Warning labels, tabs and cards are available at no cost.

▲ Les étiquettes et les panonceaux de danger et de mise en garde supplémentaires sont disponibles gratuitement.

▲ Se pueden obtener gratuitamente tarjetas y etiquetas de advertencia y de peligro, de recambio.

▲ Encontram-se disponíveis gratuitamente etiquetas, rótulos e cartões de advertência e de perigo sobressalentes.

ti2585b

# Parts Drawing / Pièces / Diagrama de peças / Desenho das peças

**FTX Gun Model: / Modèle de pistolet FTX:  
Modelos de pistola FTX: / Modelo de Pistola FTX:  
246230 – 246235, 246435, 246539, 246540**

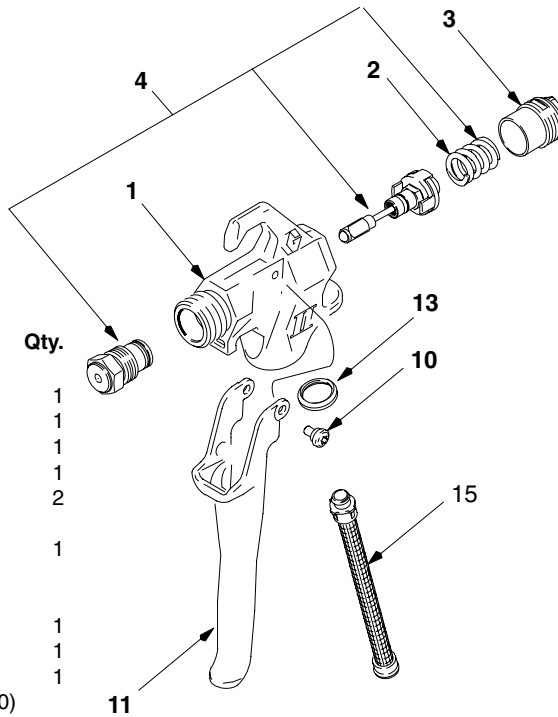

Ref. No.	Part No.	Description	Qty.
1	15B569	HOUSING	1
2	15D917	SPRING, compression	1
3	15B549	NUT, end	1
4	287031	KIT, needle, repair (includes 2)	1
10	117602	SCREW, shoulder, pan hd (included with #11)	2
11	287102	TRIGGER, 2-finger	1
	287105	TRIGGER, 4-finger	
	287106	TRIGGER, 4-finger, CE	
12	15B579	GUARD, trigger	1
13	179733	SEAL, sleeve	1
14	15B584	HANDLE	1
	15B826	HANDLE (model 246233, 246540)	
15	287032	FILTER, 60 mesh	1
	287033	FILTER, 100 mesh	
	287034	FILTER, 60 and 100 mesh combo	
16	15B903	SLEEVE, swivel	1
18	287099	SWIVEL	1
19▲	222385	WARNING CARD (not shown)	1

- ▲ Replacement Danger and Warning labels, tabs and cards are available at no cost.
- ▲ Les étiquettes et les panonceaux de danger et de mise en garde supplémentaires sont disponibles gratuitement.
- ▲ Se pueden obtener gratuitamente tarjetas y etiquetas de advertencia y de peligro, de recambio.
- ▲ Encontram-se disponíveis gratuitamente etiquetas, rótulos e cartões de advertência e de perigo sobressalentes.

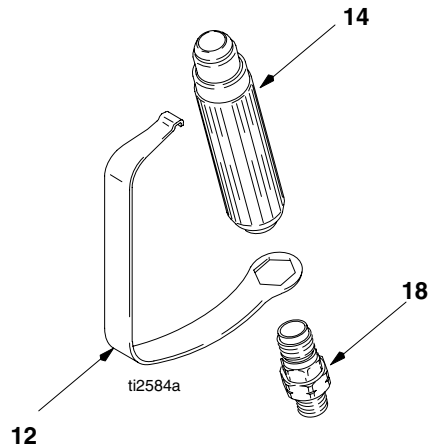

## RAC X TIP

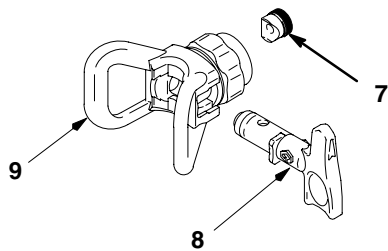

7	246453	RAC X One Seal (5-pack)	1
8	LTX517	RAC X SwitchTip, Size 517	1
9	246215	RAC X HandTite™ GUARD	1

## RAC 5 TIP

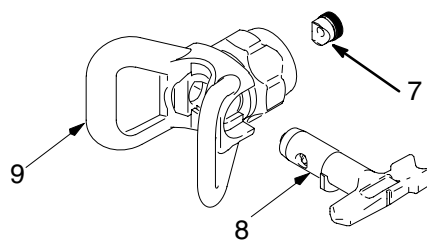

7	243281	RAC 5 OneSeal™ (5-pack)	1
8	286517	RAC 5 SwitchTip, Size 517	1
9	243161	RAC 5 HandTite™ Tip Guard	1

# Graco Standard Warranty / Garantie Graco standard / Garantía estándar de Graco / Garantia Standard da Graco

Graco warrants all equipment referenced in this document which is manufactured by Graco and bearing its name to be free from defects in material and workmanship on the date of sale to the original purchaser for use. With the exception of any special, extended, or limited warranty published by Graco, Graco will, for a period of twelve months from the date of sale, repair or replace any part of the equipment determined by Graco to be defective. This warranty applies only when the equipment is installed, operated and maintained in accordance with Graco's written recommendations.

This warranty does not cover, and Graco shall not be liable for general wear and tear, or any malfunction, damage or wear caused by faulty installation, misapplication, abrasion, corrosion, inadequate or improper maintenance, negligence, accident, tampering, or substitution of non-Graco component parts. Nor shall Graco be liable for malfunction, damage or wear caused by the incompatibility of Graco equipment with structures, accessories, equipment or materials not supplied by Graco, or the improper design, manufacture, installation, operation or maintenance of structures, accessories, equipment or materials not supplied by Graco.

This warranty is conditioned upon the prepaid return of the equipment claimed to be defective to an authorized Graco distributor for verification of the claimed defect. If the claimed defect is verified, Graco will repair or replace free of charge any defective parts. The equipment will be returned to the original purchaser transportation prepaid. If inspection of the equipment does not disclose any defect in material or workmanship, repairs will be made at a reasonable charge, which charges may include the costs of parts, labor, and transportation.

**THIS WARRANTY IS EXCLUSIVE, AND IS IN LIEU OF ANY OTHER WARRANTIES, EXPRESS OR IMPLIED, INCLUDING BUT NOT LIMITED TO WARRANTY OF MERCHANTABILITY OR WARRANTY OF FITNESS FOR A PARTICULAR PURPOSE.**

Graco's sole obligation and buyer's sole remedy for any breach of warranty shall be as set forth above. The buyer agrees that no other remedy (including, but not limited to, incidental or consequential damages for lost profits, lost sales, injury to person or property, or any other incidental or consequential loss) shall be available. Any action for breach of warranty must be brought within two (2) years of the date of sale.

**GRACO MAKES NO WARRANTY, AND DISCLAIMS ALL IMPLIED WARRANTIES OF MERCHANTABILITY AND FITNESS FOR A PARTICULAR PURPOSE, IN CONNECTION WITH ACCESSORIES, EQUIPMENT, MATERIALS OR COMPONENTS SOLD BUT NOT MANUFACTURED BY GRACO.** These items sold, but not manufactured by Graco (such as electric motors, switches, hose, etc.), are subject to the warranty, if any, of their manufacturer. Graco will provide purchaser with reasonable assistance in making any claim for breach of these warranties.

In no event will Graco be liable for indirect, incidental, special or consequential damages resulting from Graco supplying equipment hereunder, or the furnishing, performance, or use of any products or other goods sold hereto, whether due to a breach of contract, breach of warranty, the negligence of Graco, or otherwise.

## **FOR GRACO BRAZILIAN/CANADIAN/COLUMBIAN CUSTOMERS**

The Parties acknowledge that they have required that the present document, as well as all documents, notices and legal proceedings entered into, given or instituted pursuant hereto or relating directly or indirectly hereto, be drawn up in English.

## **À L'ATTENTION DES CLIENTS BRÉSILIENS/CANADIENS/COLOMBIENS DE GRACO**

Les parties reconnaissent avoir convenu que la rédaction du présente document sera en Anglais, ainsi que tous documents, avis et procédures judiciaires exécutés, donnés ou intentés à la suite de ou en rapport, directement ou indirectement, avec les procédures concernées.

## **PARA CLIENTES BRASILEIROS/CANADIANOS/COLOMBIANOS DA GRACO**

As partes confirmam que solicitaram que o presente documento, assim como todos os demais documentos, notas e processos legais inseridos, atribuídos ou instituídos de acordo com o mesmo ou relacionados directa ou indirectamente com este documento, fossem redigidos em inglês.

## **PARA LOS CLIENTES EN BRASIL/CANADÁ/COLOMBIA**

Las partes reconocen haber convenido que el presente documento, así como todos los documentos, notificaciones y procedimientos judiciales emprendidos, presentados o establecidos que tengan que ver con estas garantías directa o indirectamente, estarán redactados en inglés.

## **ADDITIONAL WARRANTY COVERAGE / AVENANT DE GARANTIE COBERTURA ADICIONAL DE LA GARANTÍA / COBERTURA DE GARANTIA ADICIONAL**

Graco does provide extended warranty and wear warranty for products described in the "Graco Contractor Equipment Warranty Program".

Graco accorde une garantie étendue et se porte garant des produits décrits dans le "Programme de garantie d'équipements des fournisseurs Graco".

Graco proporciona una garantía extendida y una garantía que cubre el desgaste de los productos descritos en el "Programa de Garantía del Equipo Contractor de Graco".

A Graco fornece prorrogação de garantia e garantia de desgaste para os produtos descritos no "Graco Contractor Equipment Warranty Program" (Programa de garantia de equipamento Contractor da Graco).

**TO PLACE AN ORDER OR FOR SERVICE**, contact your Graco distributor.  
**POUR PASSER COMMANDE OU DEMANDER UNE PRESTATION D'ENTRETIEN**, contactez votre distributeur Graco.  
**PARA REMITIR UN PEDIDO O SOLICITAR SERVICIO**, póngase en contacto con el distribuidor de Graco.  
**PARA EFECTUAR ENCOMENDAS OU PARA ASSISTÊNCIA TÉCNICA**, contacte o seu distribuidor da Graco.

## Technical Data

Maximum Working Pressure ..... 3600 psi  
(248 bar, 24.8 MPa)  
Fluid orifice size ..... 0.125 in. (3.18 mm)  
Weight (with tip and guard) ..... 19.4 oz (550 g)  
Inlet ..... 1/4 npsm swivel  
Maximum material temperature ..... 120 F (49 C)  
Wetted parts ..... Stainless steel, polyethylene,  
polyurethane, nylon, aluminum,  
acetal copolomer, tungsten carbide

Noise Level\*  
Sound power ..... 87 dBa  
Sound pressure ..... 78 dBa

\*Measured at 3.1 feet (1 m) while spraying water-base paint, specific gravity 1.36, through a 517 tip at 3000 psi (207 bar, 20.7 MPa) per ISO 3744

*All written and visual data contained in this document reflects the latest product information available at the time of publication. Graco reserves the right to make changes at any time without notice.*

*Toutes les données écrites et visuelles figurant dans ce document reflètent les toutes dernières informations disponibles au moment de sa publication. Graco se réserve le droit de procéder à des modifications à tout moment sans avis préalable.*

*Todos los datos, escritos y visuales, contenidos en este documento reflejan la información más reciente sobre el producto disponible en el momento de su publicación, Graco se reserva el derecho de realizar cambios en cualquier momento, sin previo aviso.*

*Todo o texto e desenhos contidos neste documento reflectem as mais recentes informações sobre o produto disponíveis na altura da publicação. A Graco reserva-se o direito de efectuar alterações em qualquer momento sem aviso prévio.*

**Sales Offices:** Minneapolis  
**International Offices:** Belgium, Korea, Hong Kong, Japan

**GRACO INC. P.O. BOX 1441 MINNEAPOLIS, MN 55440-1441**  
**<http://www.graco.com>**

PRINTED IN USA 309639 11/2002, Revised 11/2004  
IMPRIMÉ AUX É.-U. 309639 11/2002, Revised 11/2004  
IMPRESO EN EE.UU. 309639 11/2002, Revised 11/2004  
IMPRESSO NOS EUA 309639 11/2002, Revised 11/2004