

HVLP *EDGE*TM Gun

313317H

EN

- For the application of architectural paints and coatings. The HVLP Edge gun is not intended to be used on an external compressor. -

Models: 256855, 257092, 256856

Maximum Fluid Working Pressure: 50 psi (0.35 MPa, 3.5 bar)
Maximum Air Working Pressure: 10 psi (0.07 MPa, 0.7 bar)

Translated Manuals

English - 313317	Spanish - 313339
French - 313325	Korean - 313617
Chinese - 313618	



Important Safety Instructions

Refer to your sprayer instruction manual for **Pressure Relief** and spray instructions. Keep these instructions.

Registered Design No. 001147813-0001

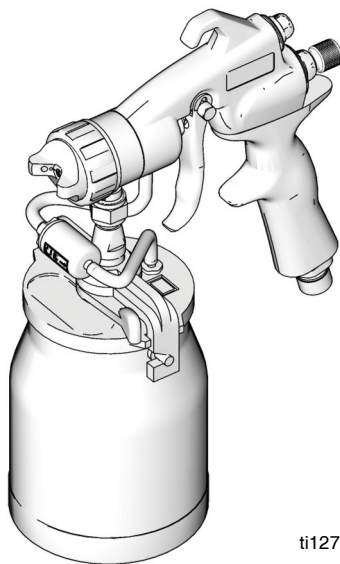

256855

ti12761a

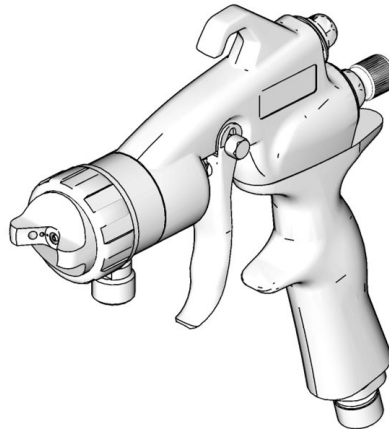

257092

ti12761a

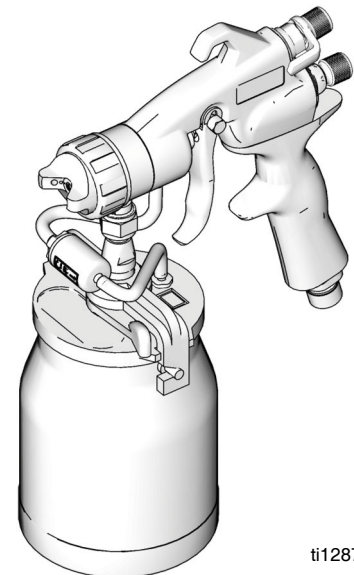





256856

ti12870a



Warnings

The following Warnings are for the setup, use, grounding, maintenance and repair of this equipment. The exclamation point symbol alerts you to a general warning and hazard symbols refer to procedure-specific risks. Refer back to these Warnings. Additional, product-specific warnings may be found throughout the body of this manual where applicable.

 WARNING	
	<p>FIRE AND EXPLOSION HAZARD</p> <p>Flammable fumes, such as solvent and paint fumes, in work area can ignite or explode. To help prevent fire and explosion:</p> <ul style="list-style-type: none"> • Use equipment only in well ventilated area. • Eliminate all ignition sources; such as pilot lights, cigarettes, portable electric lamps, and plastic drop cloths (potential static arc). • Keep work area free of debris, including solvent, rags and gasoline. • Do not plug or unplug power cords, or turn power or light switches on or off when flammable fumes are present. • Ground all equipment in the work area. See Grounding instructions. • Use only grounded hoses. • Hold gun firmly to side of grounded pail when triggering into pail. Do not use pail liners unless they are antistatic or conductive. • Stop operation immediately if static sparking occurs or you feel a shock. Do not use equipment until you identify and correct the problem. • Keep a working fire extinguisher in the work area. • When flammable liquid is sprayed or used for flushing or cleaning, keep sprayer at least 20 feet (6 meters) away from explosive vapors. • Do not clean with materials having flash points lower than 70° F (21° C). Use water-based materials or mineral spirits-type material only. For complete information about your fluid, request the MSDS from the fluid distributor or retailer.
	<p>EQUIPMENT MISUSE HAZARD</p> <p>Misuse can cause death or serious injury.</p> <ul style="list-style-type: none"> • Do not operate the unit when fatigued or under the influence of drugs or alcohol. • Do not exceed the maximum working pressure or temperature rating of the lowest rated system component. See Technical Data in all equipment manuals. • Use fluids and solvents that are compatible with equipment wetted parts. See Technical Data in all equipment manuals. Read fluid and solvent manufacturer's warnings. For complete information about your material, request MSDS from distributor or retailer. • Check equipment daily. Repair or replace worn or damaged parts immediately with genuine manufacturer's replacement parts only. • Do not alter or modify equipment. Alterations or modifications may void agency approvals and create safety hazards. • Make sure all equipment is rated and approved for the environment in which you are using it. • Use equipment only for its intended purpose. Call your distributor for information. • Route hoses and cables away from traffic areas, sharp edges, moving parts, and hot surfaces. • Do not kink or over bend hoses or use hoses to pull equipment. • Keep children and animals away from work area. • Comply with all applicable safety regulations.
	<p>PRESSURIZED ALUMINUM PARTS HAZARD</p> <p>Use of fluids that are incompatible with aluminum in pressurized equipment can cause serious chemical reaction and equipment rupture. Failure to follow this warning can result in death, serious injury, or property damage.</p> <ul style="list-style-type: none"> • Do not use 1,1,1-trichloroethane, methylene chloride, other halogenated hydrocarbon solvents or fluids containing such solvents. • Many other fluids may contain chemicals that can react with aluminum. Contact your material supplier for compatibility.
	<p>PERSONAL PROTECTIVE EQUIPMENT</p> <p>Wear appropriate protective equipment when in the work area to help prevent serious injury, including eye injury, hearing loss, inhalation of toxic fumes, and burns. This protective equipment includes but is not limited to:</p> <ul style="list-style-type: none"> • Protective eyewear, and hearing protection. • Respirators, protective clothing, and gloves as recommended by the fluid and solvent manufacturer

 **WARNING**

CALIFORNIA PROPOSITION 65

The engine exhaust from this product contains a chemical known to the State of California to cause cancer, birth defects or other reproductive harm.

Component Identification

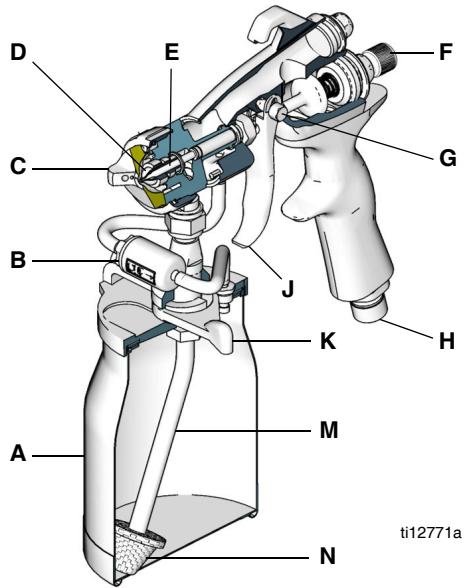

ti12771a

ID	Component	ID	Component
A	Siphon Cup	G	Trigger Slide
B	Check Valve	H	Air Inlet
C	Air Cap	J	EasyGlide™ Trigger
D	Air Nozzle	K	Latch
E	Fluid Needle	M	Swivel Tube
F	Flow Control Knob	N	Strainer

Pressure Relief Procedure

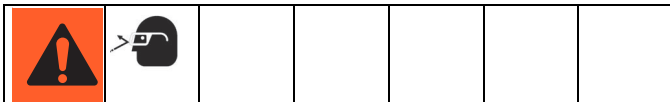

The spray gun cup is pressurized by the gun air supply. To reduce the risk of serious injury from pressurized fluid or accidental spray from gun, always turn off the air supply to the gun before removing the spray gun cup. Unplug sprayer from outlet

Setup

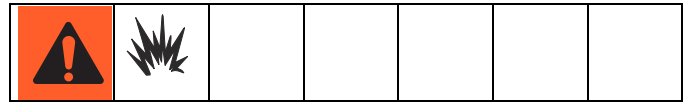

Make sure sprayer is turned off and unplugged from power source. Refer to your sprayer instruction manual for spray setup.

Connect Gun to Siphon Cup

1. Attach air hose from sprayer to inlet fitting of gun.

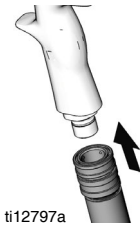

2. Fill cup 3/4 full. Install cover. Latch the gun cup cover to secure it to siphon cup.



Operation

Adjust Spray Pattern

1. Set air cap to position for spray pattern desired.

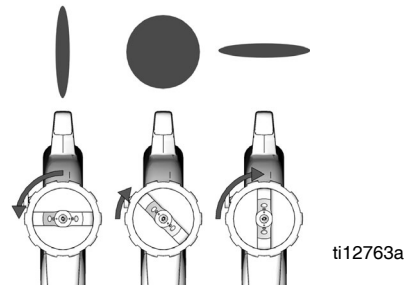

2. Verify trigger slide is in **SPRAY** position (E) and not **NEEDLE REMOVAL** position (D).

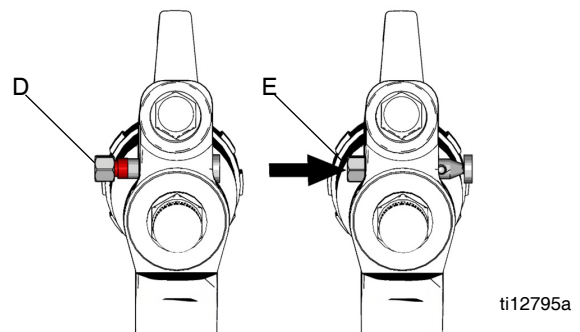

Adjust Flow and Pattern Size

Flow and pattern size is determined by the flow control knob. Set knob at **0**. Increase flow to attain desired spray pattern.

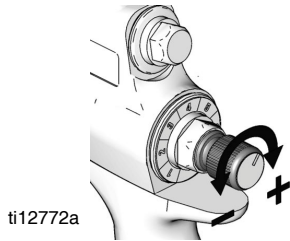

ti12772a

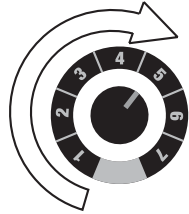

ti12823a

Spray

1. Keep gun perpendicular to surface and at a distance of 6 to 8 in. (150 to 200 mm) from surface.
2. Have spray gun in motion before triggering. Move spray gun in a straight, smooth stroke. Release trigger at end of stroke.

6 to 8 in. (150 to 200 mm)

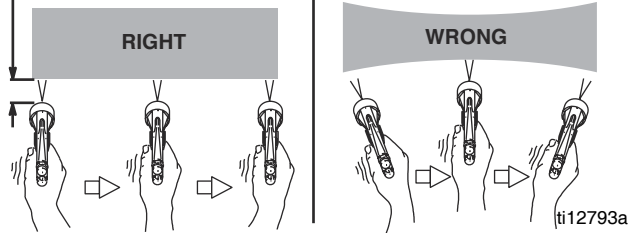

ti12793a

Cleaning Spray Gun

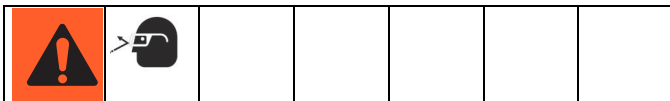

Before cleaning gun, read all warnings and do **Pressure Relief Procedure**.

1. Remove siphon cup. Empty spray material from siphon cup.



ti12775a

2. Pour small amount of solvent or water recommended by spray material manufacturer into siphon cup.



ti12775a

3. Latch the gun cup cover to secure it to siphon cup.



ti12872a

4. Swirl solvent or water inside of gun.



ti12906

5. Spray solvent or water into waste pail until spray appears to be clean.

6. Remove siphon cup. Empty remaining solvent or water from siphon cup.

7. Clean inside of siphon cup with a clean rag.



ti12905a

8. Remove retaining ring, air cap and fluid nozzle. Clean in solvent or water. Clean face of gun with a solvent or water dampened rag.

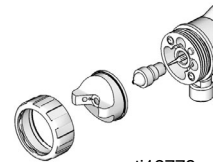

ti12778a

9. Assemble gun. Wipe gun with solvent or water dampened rag.



ti12780a

Check Valve Troubleshooting

Recommended if fluid is in the check valve.

Poppet Valve Quick Clear

1. Disconnect check valve from siphon cup air hoses.

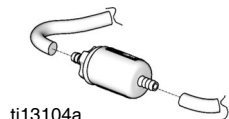

2. Unscrew check valve.

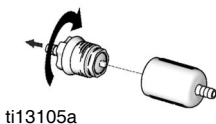

3. Pull out on nub on poppet valve and release.

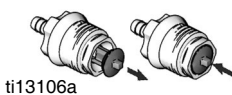

4. Assemble check valve. Install on air hoses.

5. Try spraying again to see if spraying is normal.

Check Valve Cleaning

1. Do steps 1 and 2 of **Poppet Valve Quick Clean**.

2. Unscrew poppet valve from check valve.

3. Clean all parts in solvent recommended by spray material manufacturer.

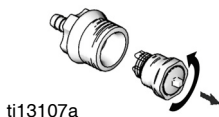

4. After all parts are dry apply a light coat of petroleum jelly all over o-ring.

5. Assemble check valve. Install on air hoses.

Needle Replacement

Removal

1. Relieve pressure.
2. Remove air cap (1).
3. Push trigger slide (4) over to NEEDLE REMOVAL position (D) shown in Component Identification, page 4.
4. Remove fluid nozzle (2).
5. Pull needle (3) out.

Installation

1. Insert needle (3).
2. Install fluid nozzle (2).
3. Push trigger slide (4) over to SPRAY position (E) shown in Component Identification, page 4.
4. Install air cap.

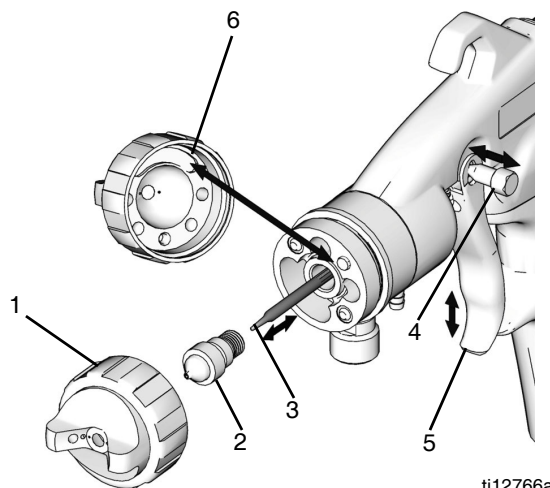

Seal Replacement and Adjustment Procedure

1. Remove air cap ring (10) and air cap housing (9)
2. Slide trigger pin (14) over to needle removal position. Lower trigger (13) to disengage needle.
3. Remove fluid nozzle (44)
4. Remove needle (44). Check fluid needle for damage or wear.
5. Remove housing nut (7) and remove housing (3) from gun body
6. Remove packing nut (8d), spacer (8c), packing (8b), and spreader (8a) from housing (3).
7. Install new spreader (8a) and packing (8b) in housing (3). Note orientation of spreader and packing.
8. Install spacer (8c).
9. Install packing nut (8d) but don't tighten until needle (44) is installed.
10. Install housing (3) into gun body and secure with nut (7).
11. Lubricate and install needle and fluid nozzle (44)
12. Raise trigger (13) to engage needle
13. Tighten packing nut (8d)
14. Trigger gun to test needle movement. If needle does not return after trigger is released or is slow to return, loosen packing nut slightly until needle returns freely.
15. Make sure gun fluid packing's are sealing properly by spraying solvent.
16. If fluid packings leak, tighten packing screw slightly and re-test until packing's seal completely.

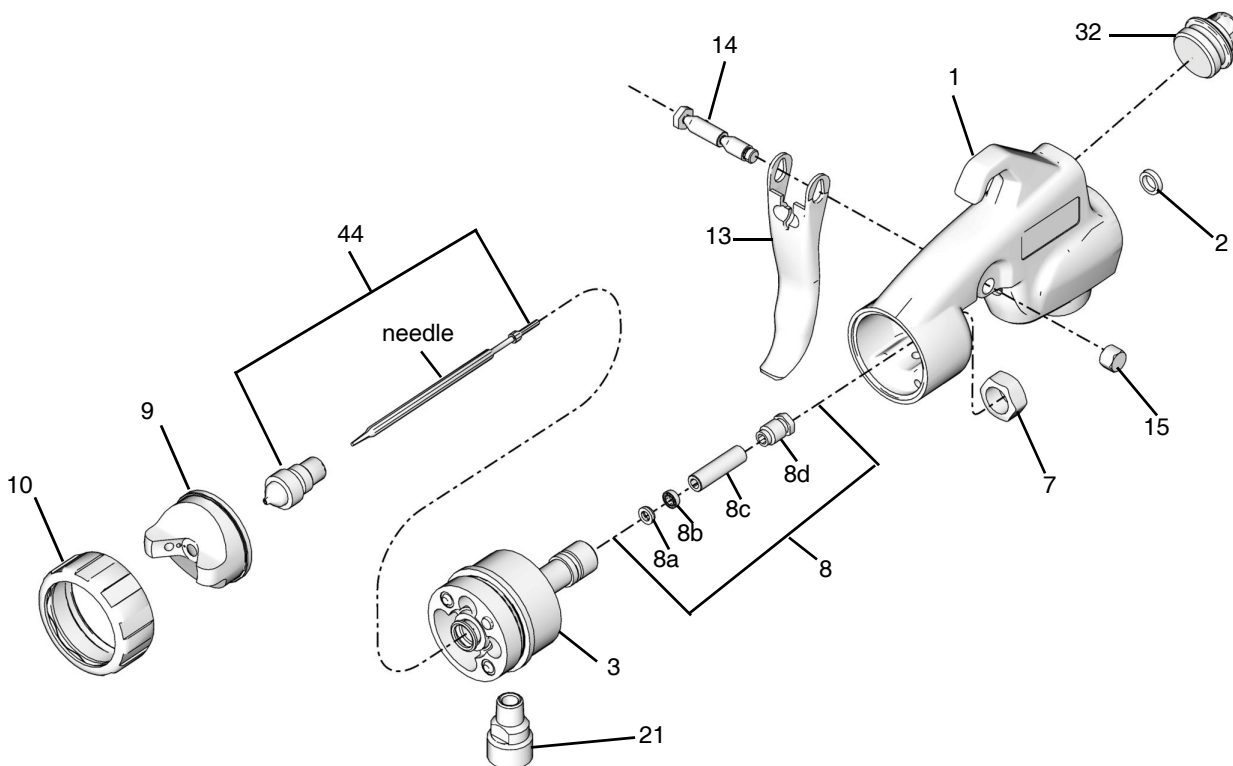

ti19030a

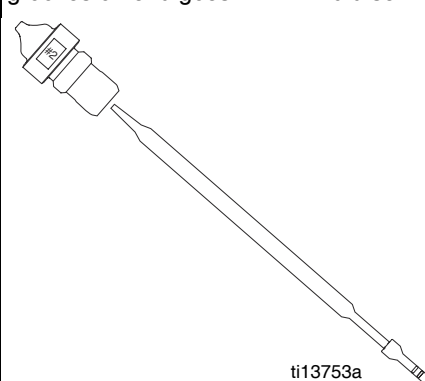
Material / Fluid Set Selection Guide						Selecting Fluid Sets: Grooves at end of fluid needle indicate size of fluid set. Example: Needle with 2 grooves on end goes with #2 fluid set.
Material	Fluid Set #2 256946	Fluid Set #3 256947	Fluid Set #4 256948	Fluid Set #5 256949	Fluid Set #6 256950	
Dye Ink Non-Wiping Stain	██████████ ██████████ ██████████					
Automotive Finish Lacquer Stain Enamel Epoxy Urethane Varnish Primer	██████████	██████████ ██████████ ██████████ ██████████ ██████████ ██████████	██████████ ██████████ ██████████ ██████████	██████████ ██████████ ██████████		
Industrial Finishes Latex Multi-Spec Butyrate Nitrate Dope Oil Wall Paint				██████████ ██████████ ██████████ ██████████ ██████████	██████████ ██████████ ██████████ ██████████	

Swivel Tube Adjustment

The adjustable swivel tube allows the gun to be held in any position while spraying.

To adjust the position of the tube in the cup:

1. Loosen nut (F). Rotate cup to desired spray position.
2. Tighten nut (F).

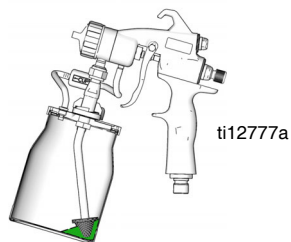
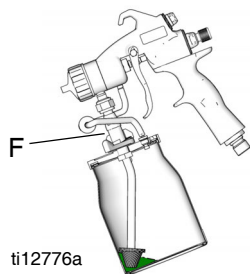

Optional Artisan Air Valve (256927)

Installation

1. Remove air plug housing.
2. Install Artisan air valve.

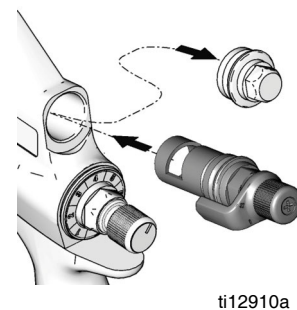

Troubleshooting

Problem	Cause	Solution
Orange peel finish - Paint surface not smooth	Paint droplets too large	<ul style="list-style-type: none"> • Maintain proper spraying distance, page 5. • Keep turbine air filters clean to allow full air flow. • Do not use an air hose that is too long to provide sufficient atomization pressure. • If droplets are still too large, reduce fluid.
	Paint droplets drying too fast to properly flow out of gun	Keep object being sprayed out of direct sunlight. When spraying in warmer temperatures, use a slower evaporating solvent or a reducer.
	Cold weather spraying	Keep fluid and object being sprayed as close to room temperature as possible. When spraying on a cold surface, most paints will become too thick to flow properly.
Blushing - clear coatings appear milky	Moisture condensation is trapped in lacquer when spraying in hot, humid conditions	<ul style="list-style-type: none"> • Allow turbine to warm up a few minutes before spraying. • Store lacquer off concrete floors, at room temperature. • Apply lighter coats and allow for proper drying time. • Use a slower evaporating solvent or reducer. • Do not spray in windy conditions.
Fish eyes - small pools on painted surface that will not fill	Silicone contamination from lubricants, grease, polish, or waxes on the surface being sprayed	Clean all parts with a cleaning solvent; wipe with a solvent rag and a clean rag. Replace rags as needed. If problem persists, use a fish eye eliminator.
Runs and sags	Applying too much paint per pass for the drying conditions	<ul style="list-style-type: none"> • Move gun faster or decrease fluid flow. • Maintain proper spraying distance, page 5. • Reduce amount of thinner or use a faster drying thinner.
Solvent pops or bubbles	Sprayed surface drying before solvent gas can be released	<ul style="list-style-type: none"> • Apply fluid in lighter coats to allow for proper evaporation. • Use the recommended thinners. • Follow the solutions for Orange Peel Finish, Paint Droplets Too Large in this Troubleshooting Table.

Problem	Cause	Solution
No or slow fluid flow, intermittent spray, or fluttering spray	Wrong size fluid set being used	Select proper fluid set for fluid being sprayed, page 6
	Gun fluid nozzle blocked by dried paint or damaged	Clean or replace fluid nozzle
	Cup or pressure pot cover not tight enough or gasket damaged	Tighten cover or replace gasket
	Cup or pressure pot fluid tubes blocked by dried paint or damaged	Clean or replace fluid tubes
	Air flow to cup blocked	To check, remove cup (leave cover connected). Trigger gun and check air flow out of check valve. If air is not flowing freely, clean or replace check valve.
	Needle packings not properly adjusted. Note: Fluid loss through packings affects fluid pressure and causes a fluid leak from gun body.	Clean gun body with solvent and brush provided. Adjust needle packings.
	Plugged inlet strainer	Replace strainer if plugged or remove strainer if material is high viscous.
Fluid leaks at fluid nozzle after trigger is released	Needle not seating in fluid nozzle	Check for a loose fluid nozzle or a bent nozzle or needle; tighten nozzle or replace parts as needed.
Poor spray pattern	Air cap horn hole and/or fluid nozzle plugged	Soak air cap and/or fluid nozzle in solvent. Clean air cap horn holes with non-metallic item to avoid permanently damaging them.

Parts

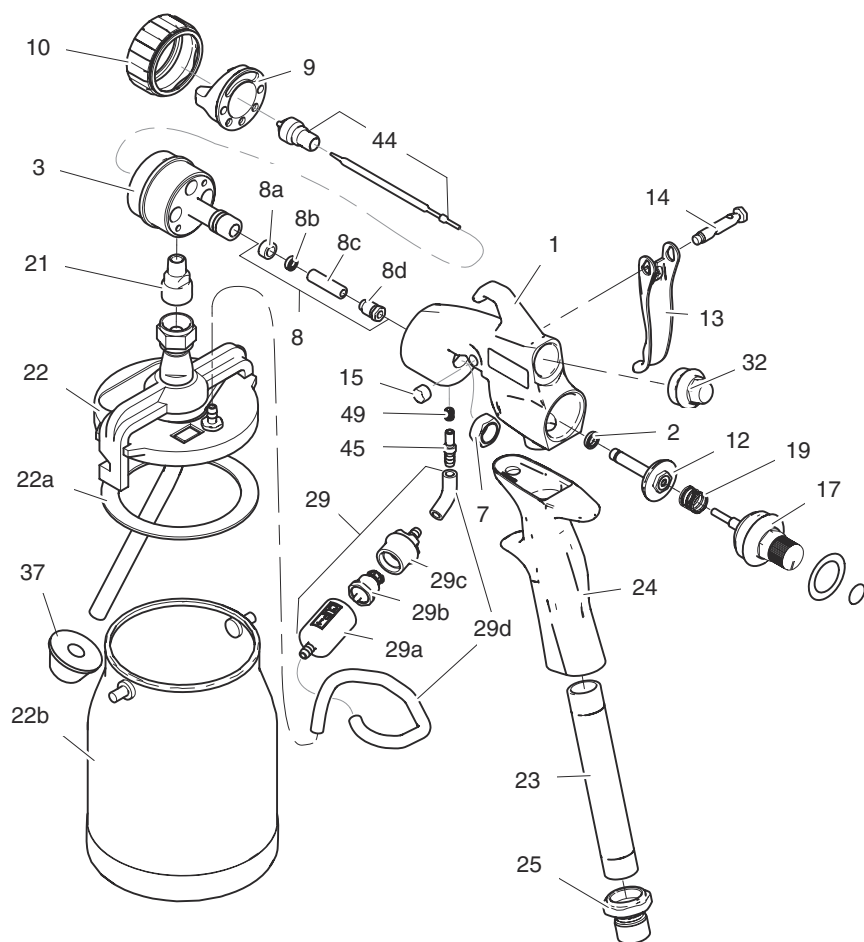

ti12764b

Ref	Part	Description	Qty	Ref	Part	Description	Qty
1	256858	BODY, gun	1	22b	244132	CUP, bottom	1
2	188493	PACKING, u-cup, gun	1	23	196463	TUBE, handle	1
3	257108	HOUSING, nozzle	1	24	277950	HANDLE, gun	1
7	192348	NUT, head	1	25	196464	COUPLER, male	1
8	256960	KIT, includes 8a, 8b, 8c, 8d	1	29	256957	CHECK VALVE, complete, includes 29a, 29b*, 29c, 29d	1
8a		SPREADER, u-cup	1	29a		FITTING, adapter	1
8b		PACKING, u-cup	1	29b*		POPPET, check valve assembly	1
8c		SPACER, packing	1	29c		FITTING, air	1
8d		NUT, head	1	29d		TUBE, air, cup	2
9	256951	HOUSING, air, cap	1	32	15V844	HOUSING, plug, fluid	1
10	256861	RING, retaining, cap, air	1	37	193218	STRAINER	1
12	257087	VALVE, air	1	44		See Material / Fluid Set Selection Guide table, page 6,	
13	15V846	TRIGGER	1	45	M70394	STEM, air pressure	1
14	280545	PIN, slide, trigger, w/ball	1	49	M71149	SCREW, set, sch	1
15	15V848	NUT, slide, trigger, pin	1			▲ Replacement Danger and Warning labels, tags, and cards are available at no cost.	
17	257086	VALVE, fluid	1			* Three-pack Check Valve Repair Kit 256956 is available	
19	114069	SPRING, compression	1				
21	196468	FITTING, adapter	1				
22	244130	CUP, 1qt, under (includes 22a, 22b)	1				
22a	M70424	CUP, gasket	1				

Technical Data

Maximum inlet fluid pressure	50 psi (0.35 MPa, 3.5 bar)
Maximum inlet air pressure	10 psi (0.07 MPa, 0.7 bar)
Air inlet	Quick-disconnect
Fluid inlet	3/8 nps
Sound levels per ISO 3744	
Sound power level	less than 65.0 dB(A)
Sound pressure level	less than 65.0 dB(A)
Wetted parts	
Bare spray gun	stainless steel, aluminum
Spray gun cups	aluminum, polyethylene
1-quart optional remote cup	aluminum, polyethylene

Graco Standard Warranty

Graco warrants all equipment referenced in this document which is manufactured by Graco and bearing its name to be free from defects in material and workmanship on the date of sale to the original purchaser for use. With the exception of any special, extended, or limited warranty published by Graco, Graco will, for a period of twelve months from the date of sale, repair or replace any part of the equipment determined by Graco to be defective. This warranty applies only when the equipment is installed, operated and maintained in accordance with Graco's written recommendations.

This warranty does not cover, and Graco shall not be liable for general wear and tear, or any malfunction, damage or wear caused by faulty installation, misapplication, abrasion, corrosion, inadequate or improper maintenance, negligence, accident, tampering, or substitution of non-Graco component parts. Nor shall Graco be liable for malfunction, damage or wear caused by the incompatibility of Graco equipment with structures, accessories, equipment or materials not supplied by Graco, or the improper design, manufacture, installation, operation or maintenance of structures, accessories, equipment or materials not supplied by Graco.

This warranty is conditioned upon the prepaid return of the equipment claimed to be defective to an authorized Graco distributor for verification of the claimed defect. If the claimed defect is verified, Graco will repair or replace free of charge any defective parts. The equipment will be returned to the original purchaser transportation prepaid. If inspection of the equipment does not disclose any defect in material or workmanship, repairs will be made at a reasonable charge, which charges may include the costs of parts, labor, and transportation.

THIS WARRANTY IS EXCLUSIVE, AND IS IN LIEU OF ANY OTHER WARRANTIES, EXPRESS OR IMPLIED, INCLUDING BUT NOT LIMITED TO WARRANTY OF MERCHANTABILITY OR WARRANTY OF FITNESS FOR A PARTICULAR PURPOSE.

Graco's sole obligation and buyer's sole remedy for any breach of warranty shall be as set forth above. The buyer agrees that no other remedy (including, but not limited to, incidental or consequential damages for lost profits, lost sales, injury to person or property, or any other incidental or consequential loss) shall be available. Any action for breach of warranty must be brought within two (2) years of the date of sale.

GRACO MAKES NO WARRANTY, AND DISCLAIMS ALL IMPLIED WARRANTIES OF MERCHANTABILITY AND FITNESS FOR A PARTICULAR PURPOSE, IN CONNECTION WITH ACCESSORIES, EQUIPMENT, MATERIALS OR COMPONENTS SOLD BUT NOT MANUFACTURED BY GRACO. These items sold, but not manufactured by Graco (such as electric motors, switches, hose, etc.), are subject to the warranty, if any, of their manufacturer. Graco will provide purchaser with reasonable assistance in making any claim for breach of these warranties.

In no event will Graco be liable for indirect, incidental, special or consequential damages resulting from Graco supplying equipment hereunder, or the furnishing, performance, or use of any products or other goods sold hereto, whether due to a breach of contract, breach of warranty, the negligence of Graco, or otherwise.

FOR GRACO CANADA CUSTOMERS

The Parties acknowledge that they have required that the present document, as well as all documents, notices and legal proceedings entered into, given or instituted pursuant hereto or relating directly or indirectly hereto, be drawn up in English. Les parties reconnaissent avoir convenu que la rédaction du présente document sera en Anglais, ainsi que tous documents, avis et procédures judiciaires exécutés, donnés ou intentés, à la suite de ou en rapport, directement ou indirectement, avec les procédures concernées.

Graco Information

For the latest information about Graco products, visit www.graco.com.

TO PLACE AN ORDER, contact your Graco distributor or call 1-800-690-2894 to identify the nearest distributor.

*All written and visual data contained in this document reflects the latest product information available at the time of publication.
Graco reserves the right to make changes at any time without notice.*

For patent information, see www.graco.com/patents.

Original instructions. This manual contains English. MM 313317

Graco Headquarters: Minneapolis
International Offices: Belgium, China, Japan, Korea

GRACO INC. AND SUBSIDIARIES • P.O. BOX 1441 • MINNEAPOLIS MN 55440-1441 • USA

Copyright 2008, Graco Inc. All Graco manufacturing locations are registered to ISO 9001.

www.graco.com

Revised November 2013