

Operation, Parts

DutyMax EH/GH675

Hydraulic Sprayers



3A5369A

EN

For professional use only.

Not approved for use in explosive atmosphere or hazardous classified locations.

For portable airless spraying of Architectural Paints, Coatings, Roof Coatings, and Below Grade Coatings.

6750 psi (46.5 MPa, 465 bar) Maximum Working Pressure

See **Models - DutyMax Hydraulic Sprayers**, page 3 for model information, including approvals.

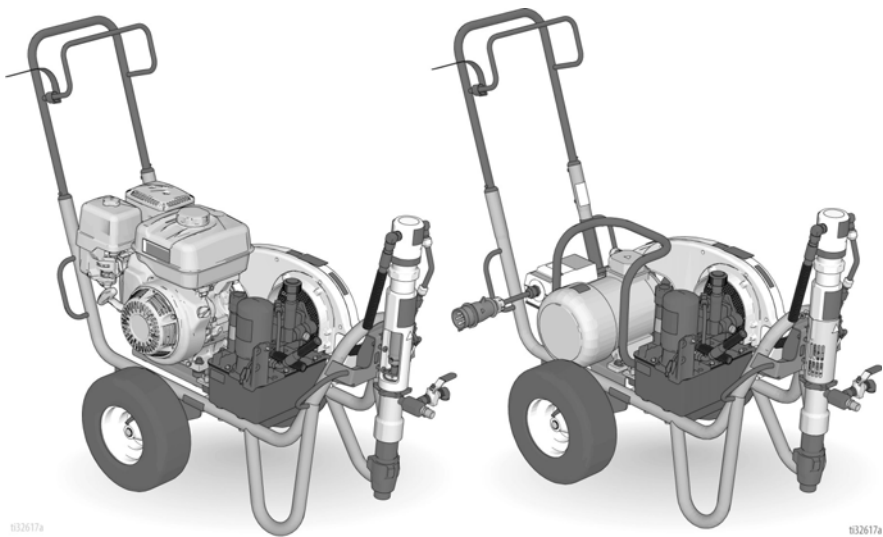

032617a

032617a



SERVICE
to every customer, every time

www.graco.com/techsupport



Important Safety Instructions

Read all warnings and instructions in this manual and in related manuals. Be familiar with the controls and the proper usage of the equipment. Save these instructions.

Use only genuine Graco replacement parts.

The use of non-Graco replacement parts may void warranty.

PROVEN QUALITY. LEADING TECHNOLOGY.

Table of Contents

Table of Contents

| | |
|---|-----------|
| Related Manuals | 3 |
| Models - DutyMax Hydraulic Sprayers | 3 |
| Optional Kits | 3 |
| Warnings | 4 |
| Component Identification | 10 |
| Models (EH/GH675) | 10 |
| Grounding | 11 |
| Grounding Procedure for Gas Engine | 11 |
| Grounding Procedure for Electric Motor | 11 |
| Grounding of Pails | 12 |
| Circuit Protection | 12 |
| Setup | 13 |
| Change Engine or Motor | 13 |
| Complete Setup | 14 |
| Pressure Relief Procedure | 15 |
| Startup (Gasoline Model) | 16 |
| Startup (Electric Model) | 19 |
| How to Spray | 21 |
| Switch Tip™ and Guard Assembly | 21 |
| Spray | 21 |
| Clear Tip Clogs | 22 |
| Clean Up | 23 |
| Maintenance | 25 |
| Troubleshooting | 26 |
| Pump Removal and Installation | 29 |
| DutyMax EH/GH675 Standard Series Parts | 31 |
| GH/EH675 Standard Series Frame and Belt Guard Parts List | 32 |
| DutyMax EH675 Electric Motor Parts List | 34 |
| DutyMax GH675 Gasoline Engine Parts List | 36 |
| Reservoir and Filter Parts List | 38 |
| Standard Series Reservoir and Filter Parts List | 39 |
| Hydraulic Motor and Displacement Pump Parts List | 40 |
| Hydraulic Motor and Displacement Pump Parts List | 41 |
| DutyMax EH/GH675 Spray Gun and Hose Parts List | 42 |
| EH Technical Data | 43 |
| DutyMax EH675 | 43 |
| GH Technical Data | 44 |
| DutyMax GH675 | 44 |
| Graco Standard Warranty | 45 |



Related Manuals

| | |
|--------|---------------------------|
| 3A5443 | Pump Manual |
| 312145 | XTR 706 Gun Manual |
| 310812 | Electric Motor Kit Manual |

Models - DutyMax Hydraulic Sprayers

| | Model | Drive Type | Hose Length | Hopper Included |
|--|--------|-------------------------|-------------|-----------------|
|  | 25D223 | 9 HP Gasoline (GH) | 50 feet | No |
| | 25D224 | 400 VAC, 50Hz, 11A (EH) | 50 feet | No |
| | 25D225 | 9 HP Gasoline (GH) | 150 feet | No |
| | 25D226 | 9 HP Gasoline (GH) | 150 feet | Yes |

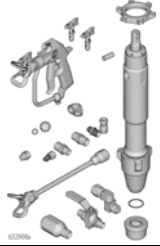
Optional Kits

| Part Number | Description | |
|-------------|-------------------------|---|
| 25D078 | 25 Gallon Hopper Kit |  |
| 17V188 | 3300 psi Pump Kit |  |
| 25D229 | 7250 psi Jet Roller Kit |  |

Warnings

Warnings

The following warnings are for the setup, use, grounding, maintenance, and repair of this equipment. The exclamation point symbol alerts you to a general warning and the hazard symbols refer to procedure-specific risks. When these symbols appear in the body of this manual or on warning labels, refer back to these Warnings. Product-specific hazard symbols and warnings not covered in this section may appear throughout the body of this manual where applicable.

Grounding Warnings

WARNING

GROUNDING

This product must be grounded. In the event of an electrical short circuit, grounding reduces the risk of electric shock by providing an escape wire for the electric current. This product is equipped with a cord having a grounding wire with an appropriate grounding plug. The plug must be plugged into an outlet that is properly installed and grounded in accordance with all local codes and ordinances.

- Improper installation of the grounding plug is able to result in a risk of electric shock.
- When repair or replacement of the cord or plug is required, do not connect the grounding wire to either flat blade terminal.
- The wire with insulation having an outer surface that is green with or without yellow stripes is the grounding wire.
- Check with a qualified electrician or serviceman when the grounding instructions are not completely understood, or when in doubt as to whether the product is properly grounded.
- Do not modify the plug provided; if it does not fit the outlet, have the proper outlet installed by a qualified electrician.
- This product is for use on a nominal 400V circuit and has a grounding plug similar to the plugs illustrated in the figure below.

400 V

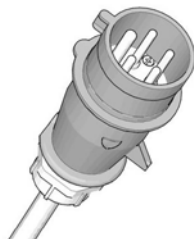

- Only connect the product to an outlet having the same configuration as the plug.
- Do not use an adapter with this product.

Extension Cords:

- Use only a cord that has a grounding plug and a grounding receptacle that accepts the plug on the product.
- Make sure your extension cord is not damaged. If an extension cord is necessary, use 12 AWG (2.5 mm²) minimum to carry the current that the product draws.
- An undersized cord results in a drop in line voltage and loss of power and overheating.



Electric Motor Warnings

 **WARNING**
FIRE AND EXPLOSION HAZARD

Flammable fumes, such as solvent and paint fumes, in **work area** can ignite or explode. To help prevent fire and explosion:

- Do not spray or clean with materials having flash points lower than 100°F (38°C). Use only non-flammable or water-based materials, or non-flammable paint thinners. For complete information about your material, request the Safety Data Sheets (SDSs) from the material distributor or retailer.
- Do not spray combustible materials near an open flame or sources of ignition such as cigarettes, motors, and electrical equipment.
- Paint or solvent flowing through the equipment is able to result in static electricity. Static electricity creates a risk of fire or explosion in the presence of paint or solvent fumes. All parts of the spray system, including the pump, hose assembly, spray gun, and objects in and around the spray area shall be properly grounded to protect against static discharge and sparks. Use Graco conductive or grounded high-pressure airless paint sprayer hoses.
- Verify that all containers and collection systems are grounded to prevent static discharge. Do not use pail liners unless they are anti-static or conductive.
- Connect to a grounded outlet and use grounded extensions cords. Do not use a 3-to-2 adapter.
- Do not use a paint or a solvent containing halogenated hydrocarbons.
- Do not spray combustible liquids in a confined area.
- Keep spray area well-ventilated. Keep a good supply of fresh air moving through the area.
- Sprayer generates sparks. Keep pump assembly in a well-ventilated area at least 20 feet (6.1 m) from the spray area when spraying, flushing, cleaning, or servicing. Do not spray pump assembly.
- Do not smoke in the spray area or spray where sparks or flame is present.
- Do not operate light switches, engines, or similar spark producing products in the spray area.
- Keep area clean and free of paint or solvent containers, rags, and other flammable materials.
- Know the contents of the paints and solvents being sprayed. Read all Safety Data Sheets (SDSs) and container labels provided with the paints and solvents. Follow the paint and solvent manufacturer's safety instructions.
- Keep a working fire extinguisher in the work area.

ELECTRIC SHOCK HAZARD

This equipment must be grounded. Improper grounding, setup, or usage of the system can cause electric shock.

- Turn off and disconnect power cord before servicing equipment.
- connect only to grounded electrical outlets.
- Use only 3-wire extension cords.
- Ensure ground prongs are intact on power and extension cords.
- Do not expose to rain. Store indoors.

Warnings

Internal Combustion Engine Warnings

WARNING



FIRE AND EXPLOSION HAZARD

Flammable fumes, such as solvent and paint fumes, in **work area** can ignite or explode. Paint or solvent flowing through the equipment can cause static sparking. To help prevent fire and explosion:



- Use equipment only in well-ventilated area.
- Do not fill fuel tank while engine is running or hot; shut off engine and let it cool. Fuel is flammable and can ignite or explode if spilled on hot surface.
- Eliminate all ignition sources; such as pilot lights, cigarettes, portable electric lamps, and plastic drop cloths (potential static sparking).
- Ground all equipment in the work area. See **Grounding** instructions.
- Never spray or flush solvent at high pressure.
- Keep work area free of debris, including solvent, rags and gasoline.
- Do not plug or unplug power cords, or turn power or light switches on or off when flammable fumes are present.
- Use only grounded hoses.
- Hold gun firmly to side of grounded pail when triggering into pail. Do not use pail liners unless they are anti-static or conductive.
- **Stop operation immediately** if static sparking occurs or you feel a shock. Do not use equipment until you identify and correct the problem.
- Keep a working fire extinguisher in the work area.



CARBON MONOXIDE HAZARD

Exhaust contains poisonous carbon monoxide, which is colorless and odorless. Breathing carbon monoxide can cause death.

- Do not operate in an enclosed area.



BURN HAZARD

Equipment surfaces and fluid that is heated can become very hot during operation. To avoid severe burns:

- Do not touch hot fluid or equipment.

Electric Motor/Internal Combustion Engine Warnings

⚠ WARNING



SKIN INJECTION HAZARD

High-pressure spray is able to inject toxins into the body and cause serious bodily injury. In the event that injection occurs, **get immediate surgical treatment.**



- Do not aim the gun at, or spray any person or animal.
- Keep hands and other body parts away from the discharge. For example, do not try to stop leaks with any part of the body.



- Always use the nozzle tip guard. Do not spray without nozzle tip guard in place.
- Use Graco nozzle tips.



- Use caution when cleaning and changing nozzle tips. In the case where the nozzle tip clogs while spraying, follow the **Pressure Relief Procedure** for turning off the unit and relieving the pressure before removing the nozzle tip to clean.



- Equipment maintains pressure after power is shut off. Do not leave the equipment energized or under pressure while unattended. Follow the **Pressure Relief Procedure** when the equipment is unattended or not in use, and before servicing, cleaning, or removing parts.

- Check hoses and parts for signs of damage. Replace any damaged hoses or parts.
- This system is capable of producing 6750 psi (46.5 MPa, 465 bar). Use Graco replacement parts or accessories that are rated a minimum of 6750 psi (46.5 MPa, 465 bar).
- Always engage the trigger lock when not spraying. Verify the trigger lock is functioning properly.
- Verify that all connections are secure before operating the unit.
- Know how to stop the unit and bleed pressure quickly. Be thoroughly familiar with the controls.



EQUIPMENT MISUSE HAZARD

Misuse can cause death or serious injury.



- Always wear appropriate gloves, eye protection, and a respirator or mask when painting.
- Do not operate or spray near children. Keep children away from equipment at all times.
- Do not overreach or stand on an unstable support. Keep effective footing and balance at all times.
- Stay alert and watch what you are doing.
- Do not operate the unit when fatigued or under the influence of drugs or alcohol.
- Do not kink or over-bend the hose.
- Do not expose the hose to temperatures or to pressures in excess of those specified by Graco.
- Do not use the hose as a strength member to pull or lift the equipment.
- Do not spray with a hose shorter than 25 feet.
- Do not alter or modify equipment. Alterations or modifications may void agency approvals and create safety hazards.
- Make sure all equipment is rated and approved for the environment in which you are using it.

Warnings

WARNING



PRESSURIZED ALUMINUM PARTS HAZARD

Use of fluids that are incompatible with aluminum in pressurized equipment can cause serious chemical reaction and equipment rupture. Failure to follow this warning can result in death, serious injury, or property damage.

- Do not use 1,1,1-trichloroethane, methylene chloride, other halogenated hydrocarbon solvents or fluids containing such solvents.
- Do not use chlorine bleach.
- Many other fluids may contain chemicals that can react with aluminum. Contact your material supplier for compatibility.



MOVING PARTS HAZARD

Moving parts can pinch, cut or amputate fingers and other body parts.

- Keep clear of moving parts.
- Do not operate equipment with protective guards or covers removed.
- Pressurized equipment can start without warning. Before checking, moving, or servicing equipment, follow the **Pressure Relief Procedure** and disconnect all power sources.



ENTANGLEMENT HAZARD

Rotating parts can cause serious injury.

- Keep clear of moving parts.
- Do not operate equipment with protective guards or covers removed.
- Do not wear loose clothing, jewelry or long hair while operating equipment.
- Equipment can start without warning. Before checking, moving, or servicing equipment, follow the **Pressure Relief Procedure** and disconnect all power sources.



TOXIC FLUID OR FUMES HAZARD

Toxic fluids or fumes can cause serious injury or death if splashed in the eyes or on skin, inhaled, or swallowed.

- Read Safety Data Sheets (SDSs) to know the specific hazards of the fluids you are using.
- Store hazardous fluid in approved containers, and dispose of it according to applicable guidelines.



RECOIL HAZARD

Gun may recoil when triggered. If you are not standing securely, you could fall and be seriously injured.

WARNING



PERSONAL PROTECTIVE EQUIPMENT

Wear appropriate protective equipment when in the work area to help prevent serious injury, including eye injury, hearing loss, inhalation of toxic fumes, and burns. Protective equipment includes but is not limited to:

- Protective eyewear, and hearing protection.
- Respirators, protective clothing, and gloves as recommended by the fluid and solvent manufacturer.

CALIFORNIA PROPOSITION 65

The engine exhaust from this product contains a chemical known to the State of California to cause cancer, birth defects or other reproductive harm.

This product contains a chemical known to the State of California to cause cancer, birth defects or other reproductive harm. Wash hands after handling.

Component Identification

Component Identification

Models (EH/GH675)

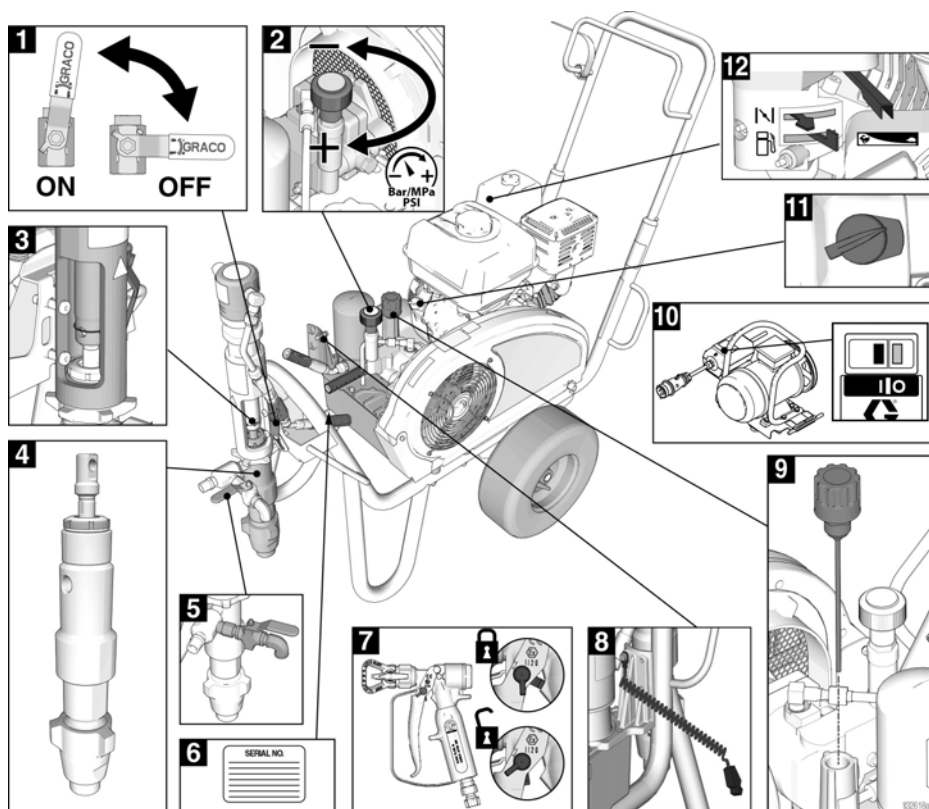

| | |
|---|--------------------------|
| 1 | Hydraulic Pump Valve |
| 2 | Pressure Control |
| 3 | Threaded Pump Connection |
| 4 | Displacement Pump |
| 5 | Prime/Drain Valve |
| 6 | Serial Number Tag |
| 7 | Gun Trigger Lock |

| | |
|----|------------------------------|
| 8 | Grounding Clamp |
| 9 | Hydraulic Oil Cap / Dipstick |
| 10 | Electric Motor ON/OFF Switch |
| 11 | Engine ON/OFF Switch |
| 12 | Engine Controls |

Grounding

Grounding Procedure for Gas Engine



The equipment must be grounded to reduce the risk of static sparking. Static sparking can cause fumes to ignite or explode. Grounding provides an escape wire for the electric current.

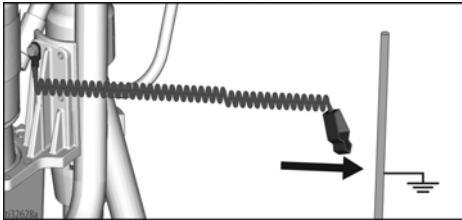

To ground sprayer: Attach sprayer grounding clamp to earth ground.

Air and fluid hoses: Use only electrically conductive hoses with a maximum of 500ft. (150 m) combined hose length to ensure grounding continuity. Check electrical resistance of hoses. If total resistance to ground exceeds 29 megaohms, replace hose immediately.

Spray gun: Ground through connection to a properly grounded fluid hose and pump.

Grounding Procedure for Electric Motor



The equipment must be grounded to reduce the risk of static sparking and electric shock. Electric or static sparking can cause fumes to ignite or explode. Improper grounding can cause electric shock. Grounding provides an escape wire for the electric current.

This sprayer is equipped with a cord having a ground wire with an appropriate grounding plug.

If using the electric motor, the plug must be plugged into an outlet that is properly installed and grounded in accordance with all local codes and ordinances.

Do not modify the plug provided; if it does not fit the outlet, have the proper outlet installed by a qualified electrician.

Power Requirements

- 380-400V units require 400 VAC, 50 Hz, 16A, 3 phase, 3P+N+E, 6h power connection
- To operate the EH675 sprayer, the generator needs to be sized for 15 kW output (minimum).

Grounding

Extension Cords

Use an extension cord with an undamaged ground contact.

NOTE: Smaller gauge or longer extension cords may reduce sprayer performance.

Grounding of Pails

Solvent pails used when flushing: Follow local code. Use only conductive metal pails, placed on a grounded surface. Do not place the pail on a non-conductive surface, such as paper or cardboard, which interrupts grounding continuity.



Always ground a metal pail: connect a ground wire to the pail. Clamp one end to the pail and the other end to a true earth ground such as a water pipe.

To maintain ground continuity when sprayer is flushed or pressure is relieved: hold metal part of spray gun firmly to the side of a grounded metal pail then trigger the gun.

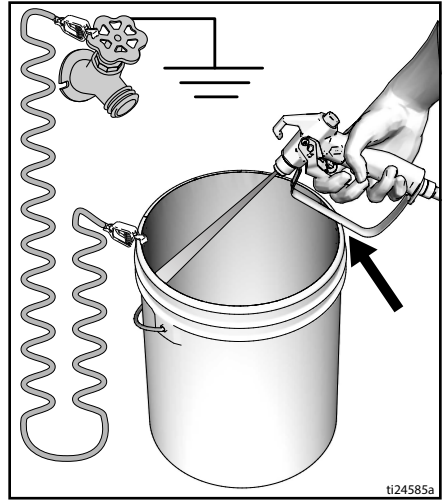

Circuit Protection

Connect sprayers only to circuits which have the properly sized circuit breaker and/or fuses (for unit power requirements see **DutyMax EH675**, page 43 technical data).

Setup

Change Engine or Motor

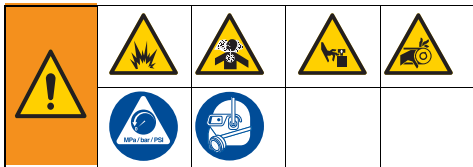

- 1 Turn motor OFF and unplug or turn engine to the OFF/STOP position. Loosen belt guard knob and motor clamp. Perform **Pressure Relief Procedure**, page 15.

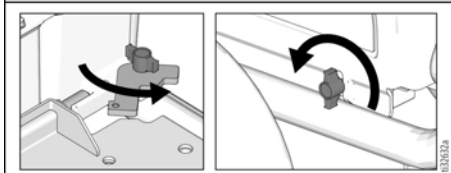
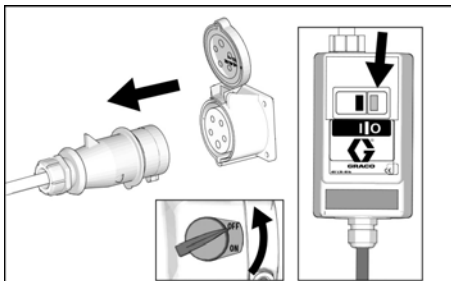

- 2 Lift belt guard. Remove belt. Tilt engine/motor and remove engine/motor.

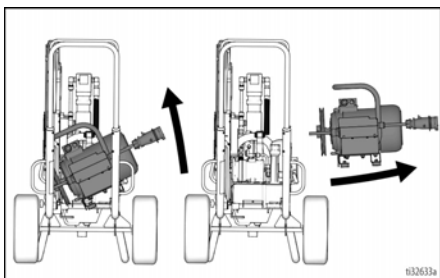

- 3 Tilt engine/motor. Install engine/motor. Install belt. Lower belt guard.

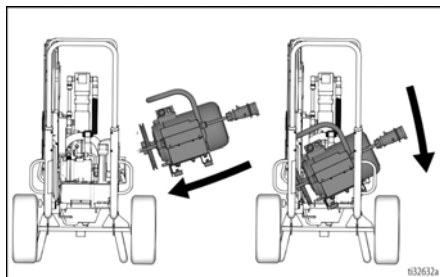

- 4 Swivel motor clamp. Tighten motor clamp and belt guard knob.

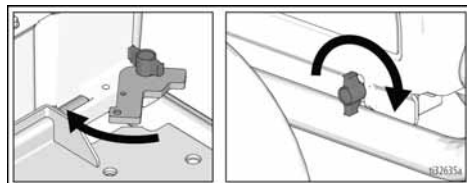

Setup

Complete Setup

1. Connect appropriate Graco high-pressure hose to sprayer.

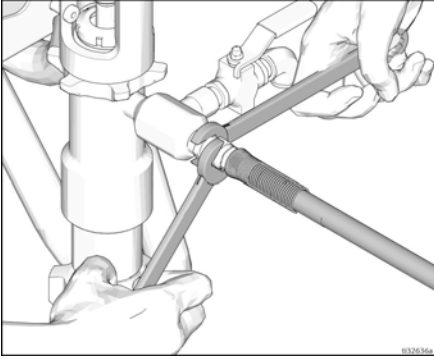

2. Install hose to spray gun and tighten securely.

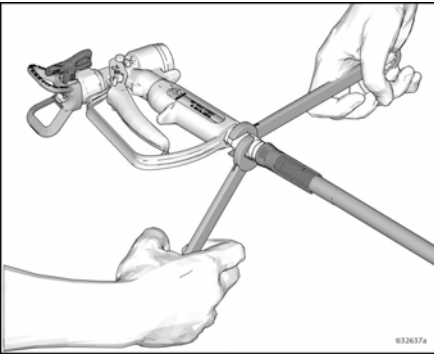

3. Engage gun trigger lock.

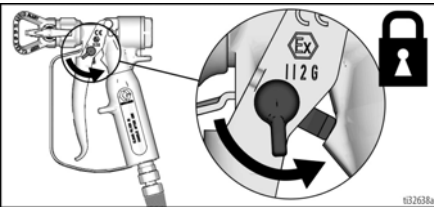

4. Remove Tip Guard.

5. Screw inlet strainer to bottom of pump and hand tighten securely.

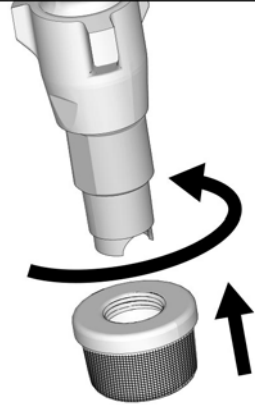

6. Fill throat packing nut with TSL to prevent premature packing wear. Do this each time you spray.

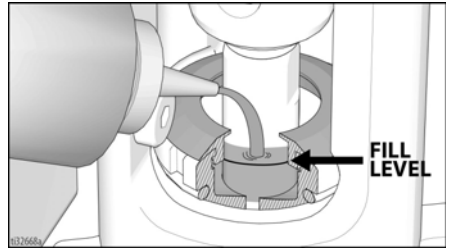

7. Check engine oil level.
GASOLINE ENGINE

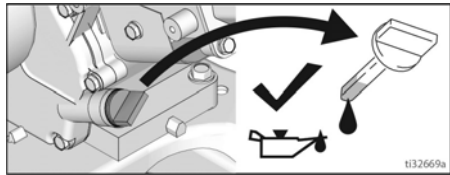

8. Fill fuel tank. GASOLINE ENGINE

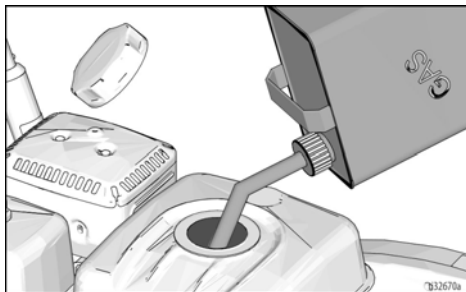

9. Check hydraulic oil level. Add only Graco Synthetic Hydraulic Oil, ISO Grade 46, 169236 (5 gallon/18.9 liter) or 207428 (1 gallon/3.8 liter). Hydraulic tank capacity is 1.25 gallon (4.75 liters).

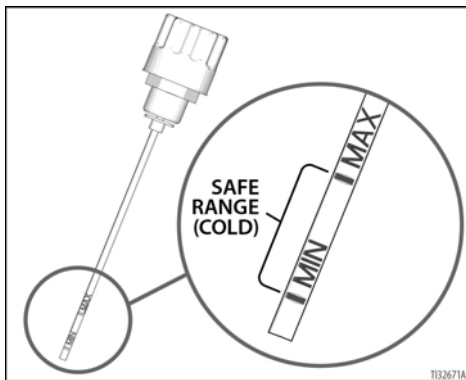

10. Attach sprayer grounding clamp to earth ground.

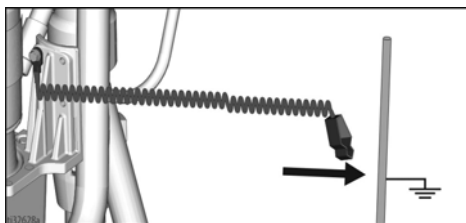

Pressure Relief Procedure



Follow the **Pressure Relief Procedure** whenever you see this symbol.

| | | | | |
|--|--|--|--|--|
| | | | | |
| | | | | |

This equipment stays pressurized until pressure is manually relieved. To help prevent serious injury from pressurized fluid, such as skin injection, splashing fluid and moving parts, follow the **Pressure Relief Procedure** when you stop spraying and before cleaning, checking, or servicing the equipment.

1. Engage trigger lock.
2. Turn sprayer OFF:
 - Turn gas engine or electric motor ON/OFF switch to OFF.
- OR
- Unplug power cord to electric motor.
3. Move pump valve to OFF and turn pressure control knob fully counter-clockwise to lowest setting.
4. Disengage trigger lock. Hold metal part of gun firmly to side of grounded metal pail, and trigger gun to relieve pressure.
5. Engage gun trigger lock.
6. Turn prime valve down to DRAIN position. Leave prime valve open until ready to spray again.
7. If you suspect the spray tip or hose is clogged or that pressure has not been fully relieved:
 - a. VERY SLOWLY loosen tip guard retaining nut or hose end coupling to relieve pressure gradually.
 - b. Loosen nut or coupling completely.
 - c. Clear the obstruction in the hose or tip.

Startup (Gasoline Model)

Startup (Gasoline Model)

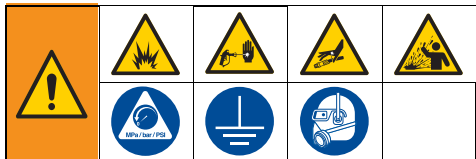

1. Place displacement pump in grounded metal pail partially filled with flushing fluid. Attach ground wire to pail and to earth ground.

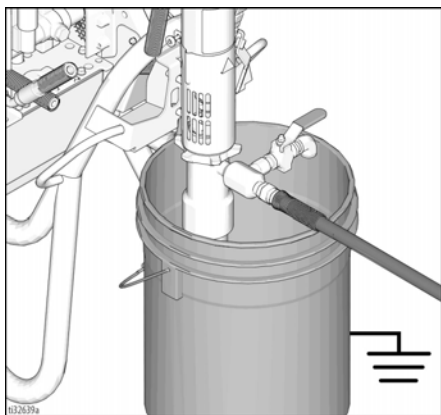

2. Turn prime valve to Drain position. Turn pressure control counterclockwise to lowest pressure.

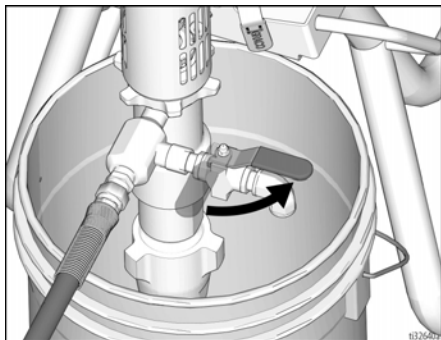

3. Set hydraulic pump valve OFF.

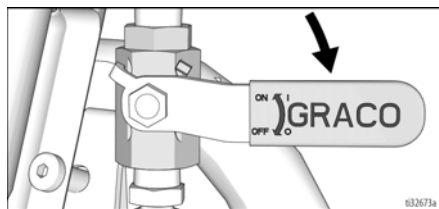

4. Start gasoline engine:
 - a. Move fuel valve to open.

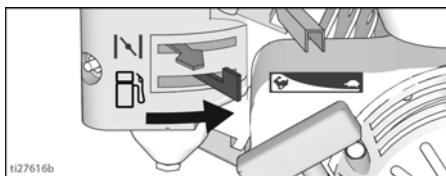

- b. Move choke to closed.

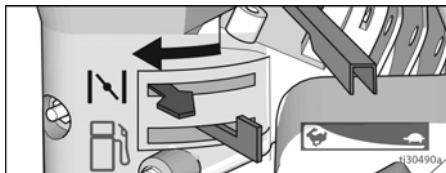

- c. Set throttle to fast.

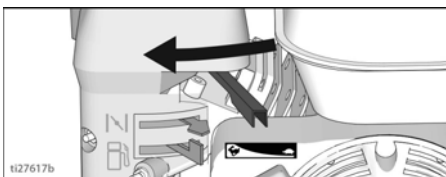

- d. Set engine switch to ON.

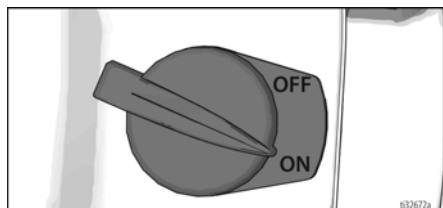

Startup (Gasoline Model)

- e. Pull starter rope.

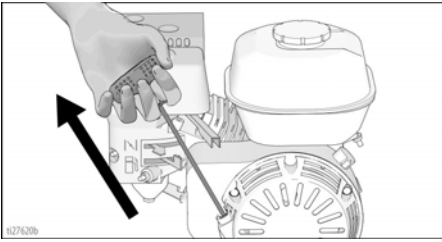

- f. After engine starts, move choke to open.

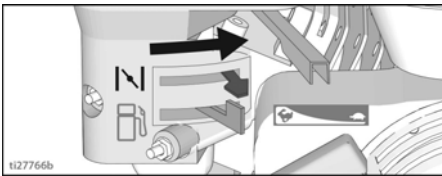

- g. Set throttle to desired setting.

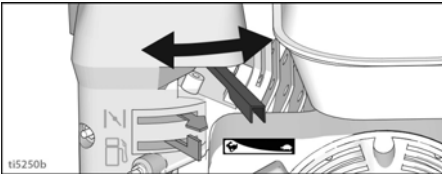

5. Set hydraulic pump valve ON (hydraulic motor is now active).

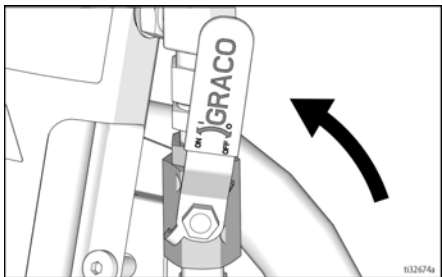

6. Increase pressure enough to start hydraulic motor stroking and allow fluid to circulate for 15 seconds; turn pressure down, turn prime valve to closed.

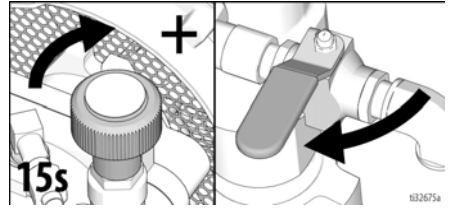

7. Disengage spray gun trigger lock.

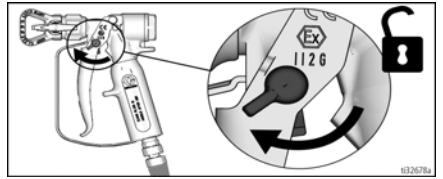

8. Hold gun against grounded metal flushing pail. Trigger gun and increase fluid pressure slowly until pump runs smoothly. Release trigger and allow sprayer to build pressure. Engage trigger lock.

| | | | | |
|---|---|---|---|--|
|  |  |  |  | |
| High-pressure spray is able to inject toxins into the body and cause serious bodily injury. Do not stop leaks with hand or rag. | | | | |

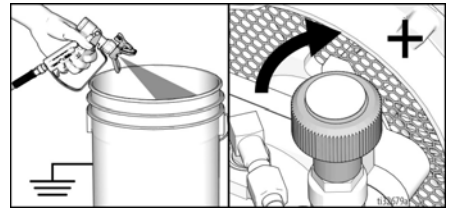

9. Inspect for leaks. If leaks occur, turn sprayer OFF immediately. Perform **Pressure Relief Procedure**, page 15. Tighten leaky fittings. Repeat **Startup** procedure steps 2-8. If no leaks, continue to trigger gun until system is thoroughly flushed.

Startup (Gasoline Model)

10. Place siphon tube in paint pail.

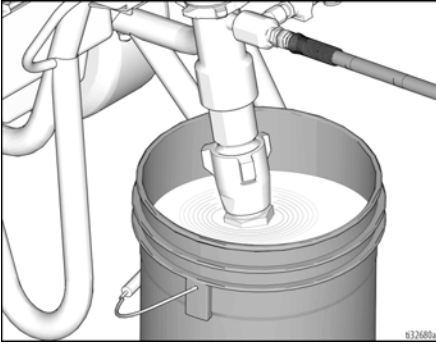

11. Trigger gun again into flushing fluid pail until paint appears.

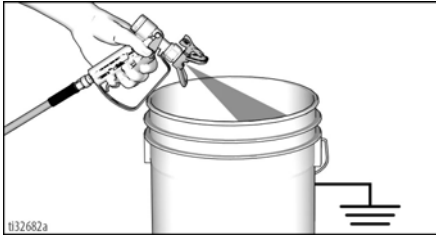

12. **How to Spray**, page 21.

Startup (Electric Model)

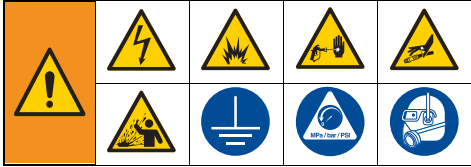

1. Place displacement pump in grounded metal pail partially filled with flushing fluid. Attach ground wire to pail and to earth ground.

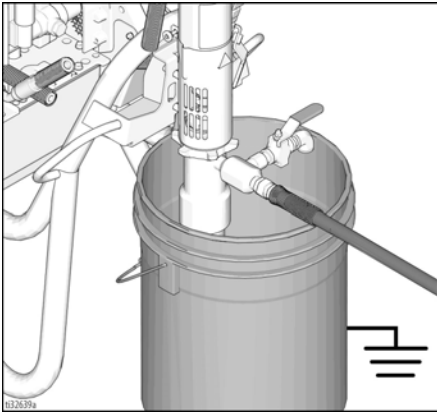

2. Turn prime valve to Drain position. Turn pressure control counterclockwise to lowest pressure.

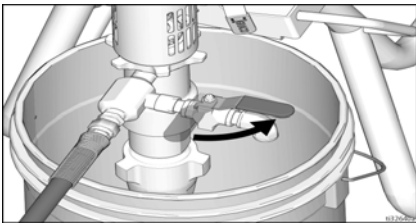

3. Set hydraulic pump valve OFF.

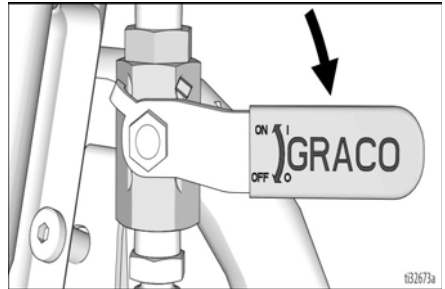

4. Plug cord into outlet.

For three phase electric motors: If red phase sequence light is on, remove plug from outlet and turn phase sequence screw 180°.

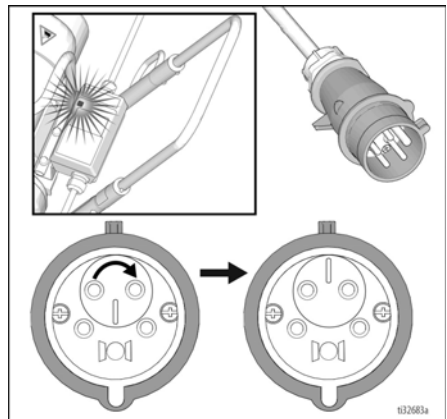

5. Turn motor ON.

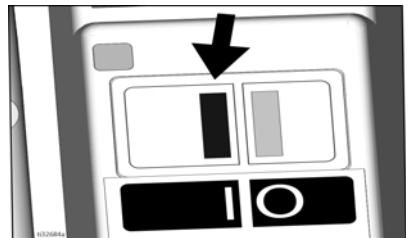

Startup (Electric Model)

6. Set hydraulic pump valve ON (hydraulic motor is now active).

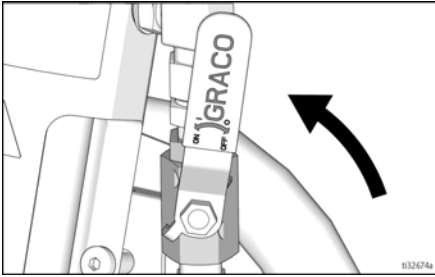

7. Increase pressure enough to start hydraulic motor stroking and allow fluid to circulate for 15 seconds; turn pressure down, turn prime valve to closed.

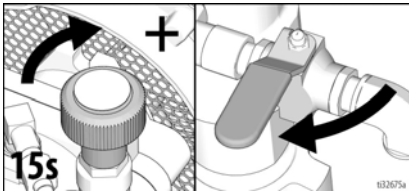

8. Disengage gun trigger lock.

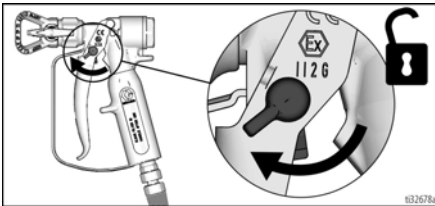

9. Hold gun against grounded metal flushing pail. Trigger gun and increase fluid pressure slowly until pump runs smoothly.

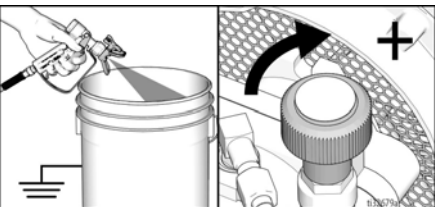

High-pressure spray is able to inject toxins into the body and cause serious bodily injury. Do not stop leaks with hand or rag.

10. Inspect fittings for leaks. If leaks occur, turn sprayer OFF immediately. Perform **Pressure Relief Procedure**, page 15. Tighten leaky fittings. Repeat **Startup** procedure steps 2-8. If no leaks, continue to trigger gun until system is thoroughly flushed.
11. Place displacement pump in paint pail.

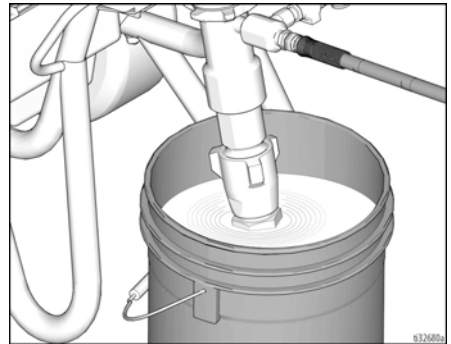

12. Trigger gun again into flushing fluid pail until paint appears.

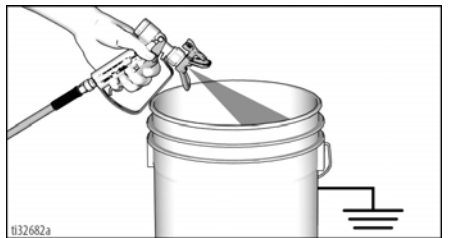

13. **How to Spray**, page 21.

How to Spray

Switch Tip™ and Guard Assembly



To avoid serious injury from skin injection do not put your hand in front of the spray tip when installing or removing the spray tip and tip guard.

To prevent spray tip leaks make certain spray tip and tip guard are installed properly.

1. Perform **Pressure Relief Procedure**, page 15.
2. Engage gun trigger lock. Insert Switch Tip. Insert seat and OneSeal™.

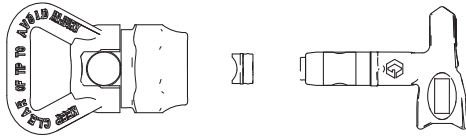

ti13023a

3. Insert Switch Tip and face forward.

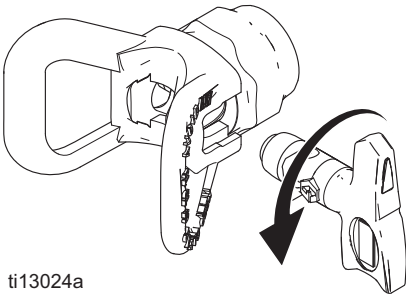

ti13024a

4. Screw assembly onto gun. Tighten.

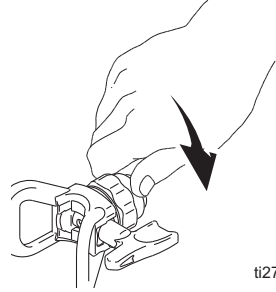

ti2710a

Spray

1. Spray test pattern. Increase pressure to eliminate heavy edges. Use smaller tip size if pressure adjustment can not eliminate heavy edges.

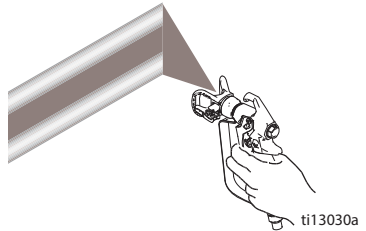

ti13030a

2. Hold gun perpendicular, 10-12 in. (25-30 cm) from surface. Spray back and forth. Overlap by 50%. Trigger gun

How to Spray

after moving and release before stopping.

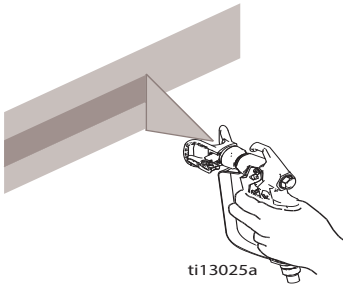

Clear Tip Clogs



1. Release trigger. Engage trigger lock. Rotate Switch Tip. Disengage trigger lock. Trigger gun to clear clog.

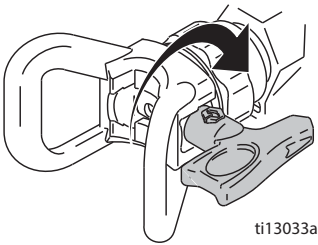

2. Engage trigger lock. Return Switch Tip to original position. Disengage trigger lock and continue spraying.

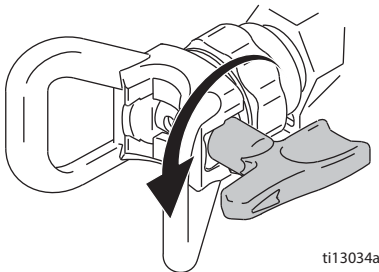

Clean Up



1. Perform **Pressure Relief Procedure**, page 15.
2. Remove Guard and SwitchTip.

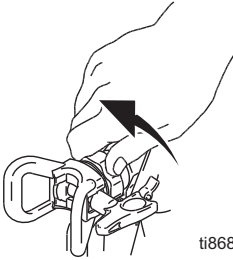

ti8687a

3. Remove displacement pump from paint and place in flushing fluid. Use water for water-based paint and mineral spirits for oil based paint.

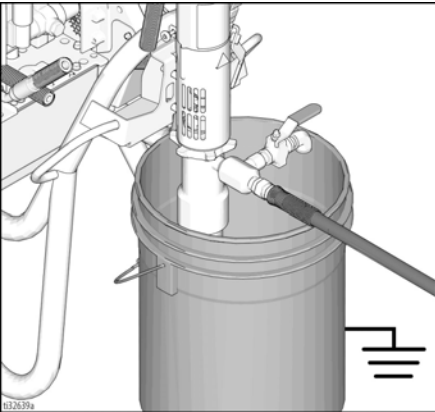

4. Turn motor switch ON or turn engine ON and start engine. Turn hydraulic

pump valve ON. Turn prime valve to SPRAY position.

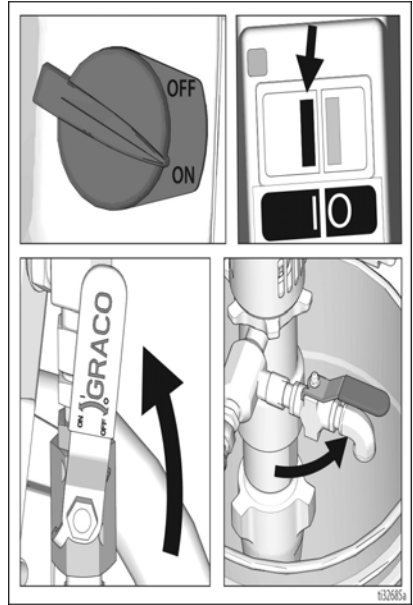

5. Hold gun against pail. Disengage trigger lock. Turn pressure control up until motor begins to drive pump. Trigger gun until flushing fluid appears.

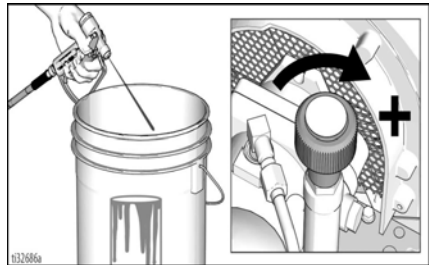

Clean Up

6. Move gun to waste pail, hold gun against pail, trigger gun to thoroughly flush system.

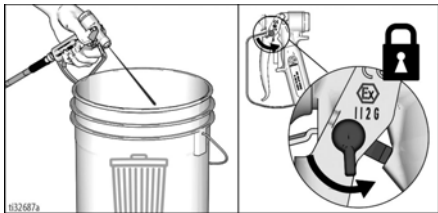

7. While continuing to trigger gun, turn prime valve to open. Then release gun trigger and engage trigger lock. Allow flushing fluid to circulate until fluid comes out of drain tube clear.

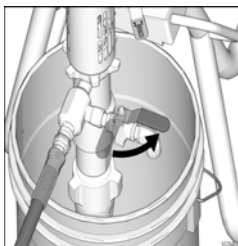

8. Raise displacement pump above flushing fluid and run sprayer for 15 to 30 seconds to drain fluid. Turn hydraulic valve OFF. Turn engine OFF or turn electric motor OFF and unplug.

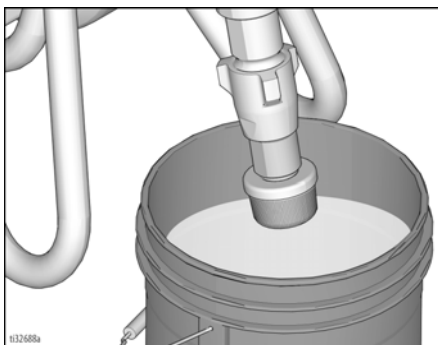

9. Unscrew and remove inlet strainer. Clean and replace strainer if necessary.

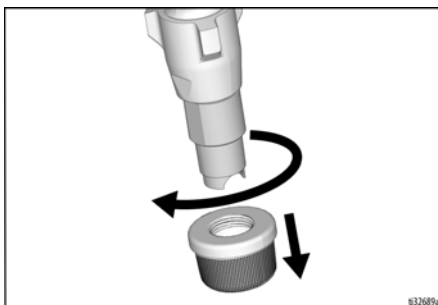

10. If flushing with water, flush again with mineral spirits, or Pump Armor™, to leave a protective coating to prevent freezing or corrosion.
11. Wipe sprayer, hose and gun with a rag soaked in water or mineral spirits.

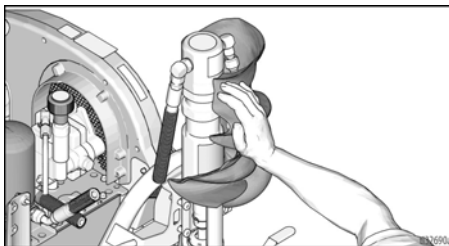

Maintenance



NOTE: For detailed engine maintenance and specifications, refer to separate Honda Engine Owner's Manual, supplied.

DAILY: Check engine oil level and fill as necessary.

DAILY: Check hydraulic oil level and fill as necessary.

DAILY: Check hose for wear and damage.

DAILY: Check gun trigger lock for proper operation.

DAILY: Check prime/drain valve for proper operation.

DAILY: Check and fill the fuel tank.

DAILY: Check that displacement pump is tight.

DAILY: Check level of Throat Seal Liquid (TSL) in displacement pump packing nut. Fill nut, if necessary. Keep TSL in nut to help prevent fluid buildup on piston rod and premature wear of packings and pump corrosion.

GASOLINE ENGINE, AFTER THE FIRST 20 HOURS OF OPERATION: Drain engine oil and refill with clean oil. Reference Honda Engine Owner's Manual for correct oil grade.

WEEKLY: Remove engine air filter cover and clean element. Replace element, if necessary. If operating in an unusually dusty environment: check filter daily and replace, if necessary.

Replacement elements can be purchased from your local HONDA dealer.

WEEKLY/DAILY: Remove any debris or media from hydraulic rod.

AFTER EACH 100 HOURS OF OPERATION: Change engine oil. Reference Honda Engines Owner's Manual for correct oil viscosity.

SEMI-ANNUALLY: Check belt wear. Replace if necessary.

AFTER EACH 500 HOURS OR 3 MONTHS OF OPERATION: Replace hydraulic oil and filter with Graco hydraulic oil 169236 (5 gallon/20 liter) or 207428 (1 gallon/3.8 liter) and filter 246173. Oil change interval dependent on environmental conditions.

YEARLY OR 2000 HOURS: Replace belt.

SPARK PLUG: Use only BPR6ES (NGK) or W20EPR-U (NIPPONDENSO) plug. Gap plug to 0.028 to 0.031 in. (0.7 to 0.8 mm). use spark plug wrench when installing and removing plug.

Troubleshooting



| Problem | Cause | Solution |
|---|--|---|
| Internal combustion engine pulls hard (won't start) | Hydraulic pressure is too high | Turn hydraulic pressure knob counterclockwise to lowest setting |
| Gasoline engine does not start | Switch OFF, low oil, no gasoline | Consult engine manual |
| | Fuel shut off valve closed | Open fuel shut off valve |
| Gasoline engine does not work properly | Faulty engine | Consult engine manual |
| | Elevation | Refer to Engine Repair Kit, 9.0 hp - 248945 |
| Internal combustion engine operates, but displacement pump does not operate | Hydraulic pump valve is OFF | Set hydraulic pump valve ON |
| | Pressure setting too low | Increase pressure, page 18 |
| | Tip or tip filter (if used) is clogged | Remove tip and/or filter and clean |
| | Hydraulic fluid too low | Shut off sprayer. Add fluid*. See page 16 |
| | Belt worn or broken or off | Replace. |
| | Hydraulic pump worn or damaged | Bring sprayer to Graco distributor for repair |
| | Dried paint seized paint pump rod | Service pump. See manual 3A5443 |
| Displacement pump operates, but output is low on upstroke | Hydraulic motor not shifting | Set pump valve OFF. Turn pressure down. Turn engine OFF. Pry rod up or down until hydraulic motor shifts. |
| | Piston ball check not seating properly | Service piston ball check. See manual 3A5443 |
| | Piston packings worn or damaged | Replace packings. See manual 3A5443 |

| Problem | Cause | Solution |
|---|---|--|
| Displacement pump operates, but output is low on down stroke and/or on both strokes | Piston packings worn or damaged | Tighten packing nut or replace packings. See manual 3A5443 |
| | Intake valve ball check not seating properly | Service intake valve ball check. See manual 3A5443 |
| | Suction tube air leak | |
| | Hydraulic oil filter is dirty | Replace filter. |
| Paint leaks and runs over side of wet cup | Loose wet cup | Tighten wet cup enough to stop leakage |
| | Throat packings worn or damaged | Replace packings. See manual 3A5443 |
| Excessive leakage around hydraulic motor piston rod wiper | Piston rod seal worn or damaged | Replace these parts. See manual 3A5443 |
| Fluid delivery is low | Pressure setting too low | Increase pressure, page 18 |
| | Displacement pump outlet filter (if used) is dirty or clogged | Clean or replace. |
| | Contractor gun filter (if used) is dirty or clogged | Clean or replace. |
| | Intake line to pump inlet is not tight | Tighten. |
| | Hydraulic motor is worn or damaged | Bring sprayer to Graco distributor for repair. |
| | Large pressure drop in fluid hose | Reduce length or increase diameter. |
| The sprayer overheats | Paint buildup on hydraulic components | Clean |
| | Oil level is low | Fill with oil. See page 16 |
| Spitting from gun | Air in fluid pump or hose | Check for loose connections on siphon assembly, tighten, then reprime pump |
| | Loose intake suction | Tighten |
| | Fluid supply is low or empty | Refill supply container |
| Pump noise | Low hydraulic fluid level | Turn sprayer OFF. Add fluid*. See page 16 |
| Electric motor does not operate | Power switch is not ON | Turn power switch ON |

Troubleshooting

| Problem | Cause | Solution |
|---|-------------------------|---|
| | Tripped circuit breaker | Check circuit breaker at power source. Reset motor switch |
| *Check hydraulic fluid level often. Do not allow it to become too low. Use only Graco hydraulic fluid, page 16. | | |

Pump Removal and Installation

Removal



See pump manual 3A5443 for pump repair.

1. Flush pump.
2. Perform **Pressure Relief Procedure**, page 15.
3. Remove strainer and paint hose.

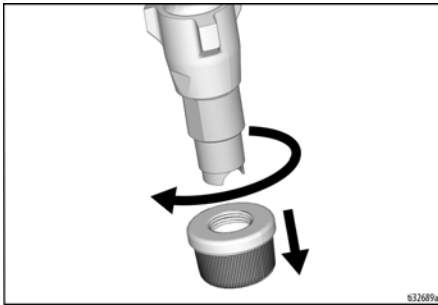

4. Push retaining ring up; push out pin.

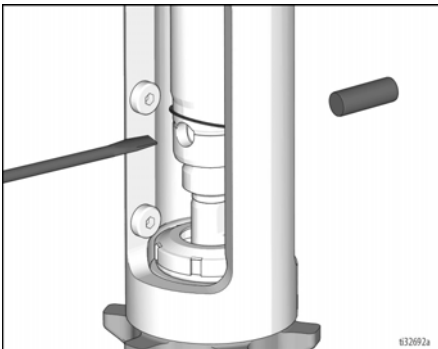

5. Loosen jam nut. Unscrew pump.

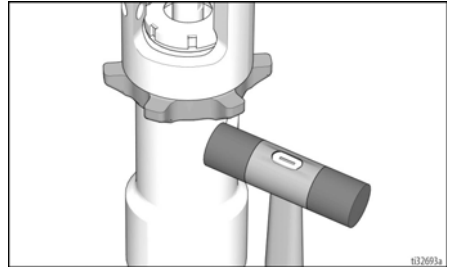

Pump Removal and Installation

Installation

NOTICE

If pump jam nut loosens during operation, the threads of the bearing housing and drive train will be damaged. Tighten jam nut as specified.

1. Screw jam nut to bottom of pump threads. Screw pump completely into manifold. Unscrew pump from manifold until pump outlet aligns with hose. Hand tighten jam nut, then tap 1/8 to 1/4 turn with hammer.

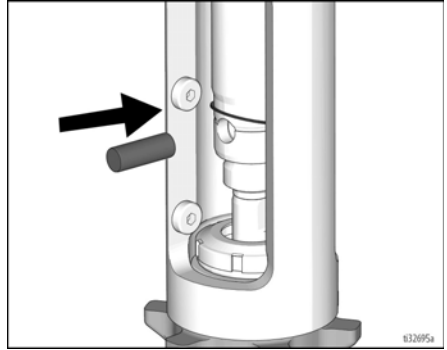
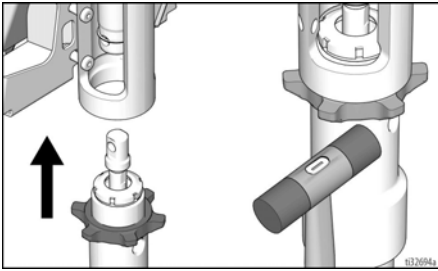

3. Fill packing nut with Graco TSL.

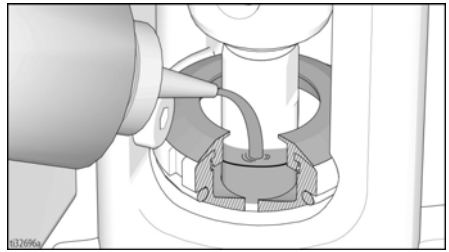

| | | | | |
|---|--|--|--|--|
| | | | | |
| <p>If pin is loose, parts could break off and project through the air, resulting in serious injury or property damage. Make sure pin is properly installed.</p> | | | | |

2. Slowly pull engine starter rope until pump rod pin hole is aligned with hydraulic rod hole. Push pin into hole. Push retaining ring into groove.



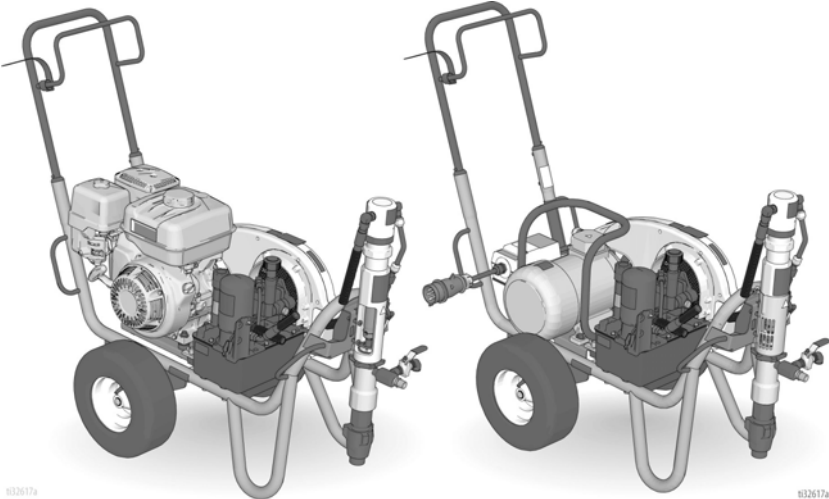

DutyMax EH/GH675 Standard Series Parts

DutyMax EH/GH675 Standard Series Parts



GH/EH675 Standard Series Frame and Belt

GH/EH675 Standard Series Frame and Belt Guard Parts List

| Ref. | Torque | Ref. | Torque |
|---|----------------|---|--|
|  | 25-35 in-lbs |  | Inflate tires to 25-35 psi (1.7-2.4 bar) |
|  | 125 ± 5 in-lbs |  | 25-32 in-lbs |

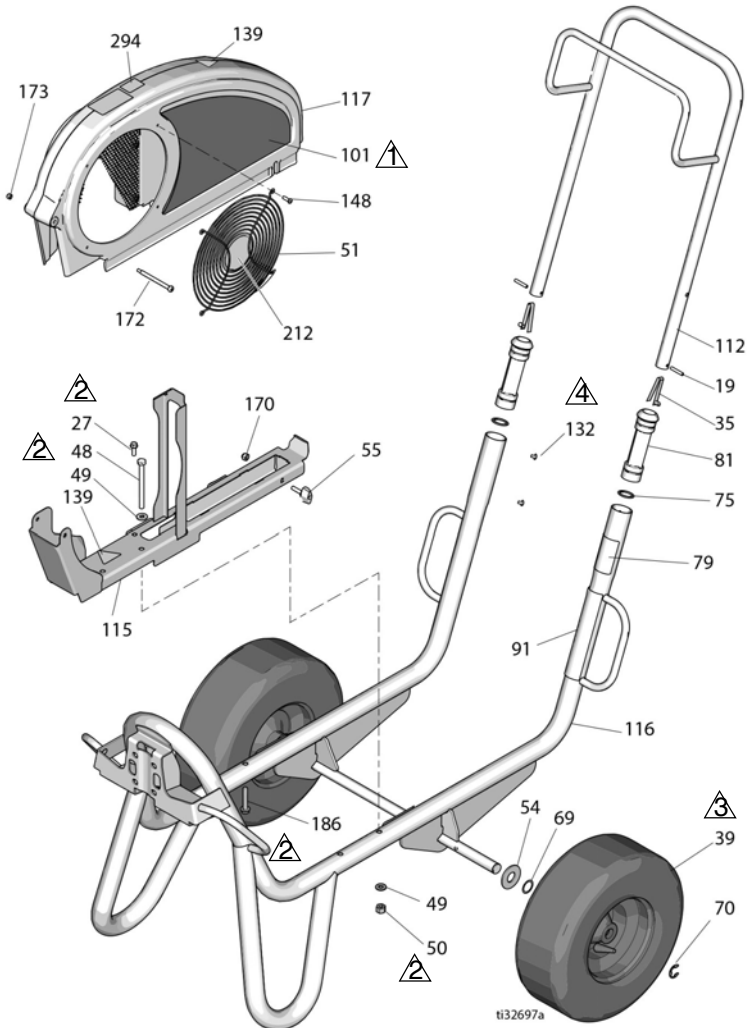

GH/EH675 Standard Series Frame and Belt

Parts List

| Ref. | Part | Description | Qty. | Ref. | Part | Description | Qty. |
|------|--------|---|------|------|--------|----------------------------------|------|
| | | | | 170 | 102040 | NUT, lock, hex | 1 |
| | | | | 172 | 119434 | SCRWE, shoulder, skt hd | 1 |
| 19 | 101354 | PIN, spring, straight | 2 | 173 | 116969 | NUT, lock | 1 |
| 27 | 260212 | SCREW, hex washer hd, thd form | 1 | 212 | 16N398 | LABEL, direction (EH/GH300DI) | 1 |
| 35 | 112827 | BUTTON, snap | 2 | 294 | 16D576 | LABEL, made in USA | 1 |
| 38 | 114271 | STRAP, retaining | 1 | 295 | 16X983 | LABEL, standard series | 1 |
| 39 | 119509 | WHEEL, pneumatic | 2 | | | | |
| 48 | 867539 | SCREW, cap, hex hd | 2 | | | | |
| 49 | 100527 | WASHER, plain | 4 | | | | |
| 50 | 110838 | NUT, lock | 2 | | | | |
| 51 | 117284 | GRILL, fan guard | 1 | | | | |
| 54 | 156306 | WASHER, flat | 2 | | | | |
| 55 | 17D813 | NUT, hand | 2 | | | | |
| 69 | 116038 | WASHER, wave spring | 2 | | | | |
| 70 | 120211 | RING, retaining, e-ring | 2 | | | | |
| 75 | 15J645 | WASHER | 2 | | | | |
| 79▲ | 189246 | LABEL, warning | 1 | | | | |
| | 17D947 | LABEL, warning, multi-languages | 1 | | | | |
| 81 | 192027 | SLEEVE, cart | 2 | | | | |
| 91▲ | 194317 | LABEL, warning | 1 | | | | |
| | 16N948 | LABEL, warning, ISO | 1 | | | | |
| | 17D947 | LABEL, warning, multi-languages | 1 | | | | |
| 101 | 17D042 | LABEL, brand, side (EH230DI) | 1 | | | | |
| | 17D044 | LABEL, brand, side (GH230DI) | 1 | | | | |
| | 17D046 | LABEL, brand, side (EH300DI) | 1 | | | | |
| | 17D048 | LABEL, brand, side (GH300DI) | 1 | | | | |
| 112 | 24M397 | HANDLE, cart | 1 | | | | |
| 115 | 24M086 | RAIL, belt guard, assy | 1 | | | | |
| 116 | 24M085 | FRAME, cart, weldment | 1 | | | | |
| 117 | 248973 | GUARD, belt assembly, painted (includes 51, 148, 172, 173) | 1 | | | | |
| 132 | 109032 | SCREW, mach, pnh | 4 | | | | |
| 139 | 16M768 | LABEL, warning | 2 | | | | |
| ▲ | | | | | | | |
| 141 | 15Y963 | LABEL, read instructions | 1 | | | | |
| ▲ | | | | | | | |
| 148 | 115477 | SCREW, mach, torx pan hd | 4 | | | | |

▲ *Danger and Warning labels are available at no cost.*

DutyMax EH675 Electric Motor Parts List

DutyMax EH675 Electric Motor Parts List

| Ref. | Torque | Ref. | Torque |
|------|-------------------|------|-----------------|
| 1 | 58-62 in-lb | 3 | 225 ± 10 in-lbs |
| 2 | Apply Loctite 242 | 4 | 14-18 in-lbs |

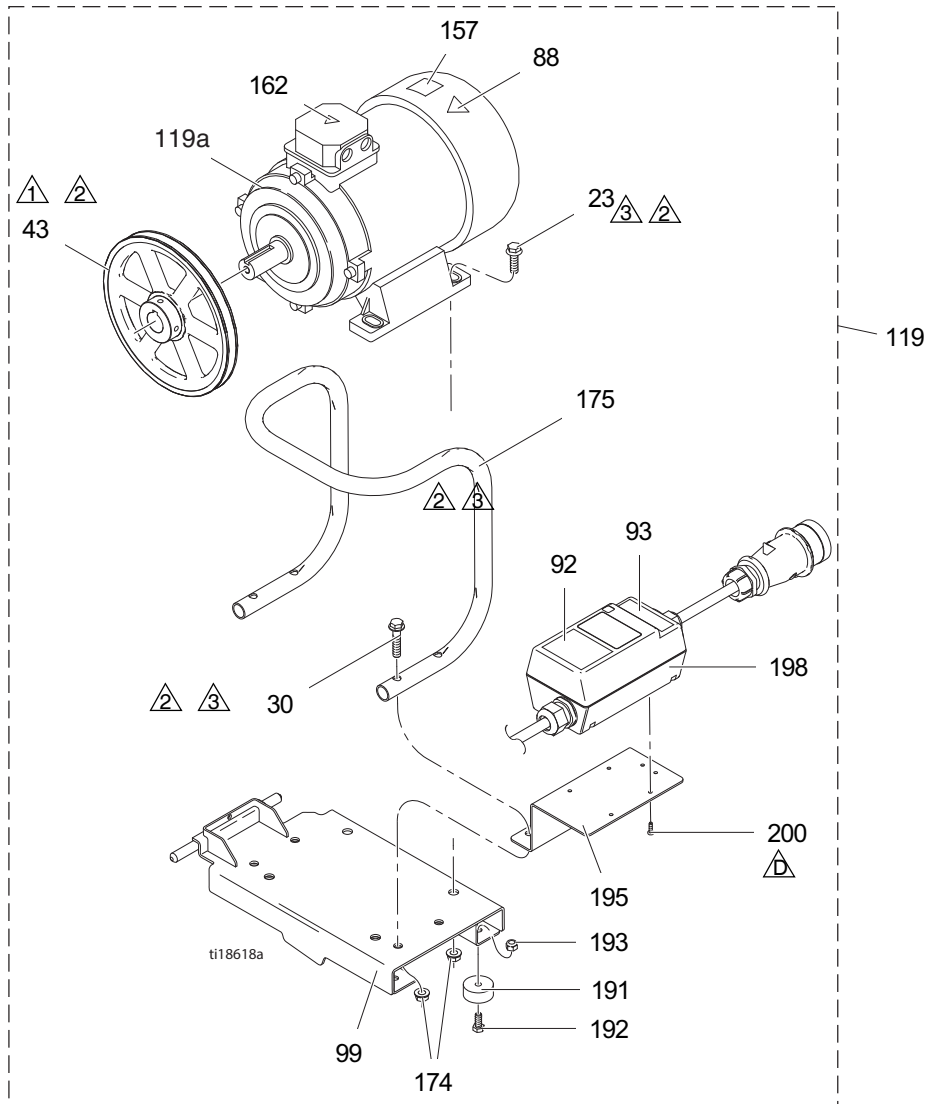

DutyMax EH675 Electric Motor Parts List

| Ref. | Part | Description | Qty. |
|------|--------|---|------|
| 23 | 111193 | SCREW, cap, flange head | 4 |
| 30 | 116780 | SCREW, hex, hd, flanged | 4 |
| 43 | 125811 | PULLEY, cast iron, 8.75 in | 1 |
| 88▲ | 15K61 | LABEL, caution | 1 |
| | 6 | | |
| 92 | 16N39 | LABEL, motor switch box on-off | 1 |
| | 9 | | |
| 93 | 16N40 | LABEL, red light indicator | 1 |
| | 0 | | |
| 99 | 16M46 | BRACKET, mounting, motor, EH300 | 1 |
| | 7 | | |
| 119 | 24M66 | KIT, motor (includes all parts listed on this page) | 1 |
| | 9 | | |
| 119 | 24N01 | MOTOR, elec., 400 VAC, 50 Hz, 7.3 hp | 1 |
| a | 9 | | |
| 162 | 189930 | LABEL, caution | 1 |
| ▲ | | | |
| 174 | 112958 | NUT, hex, flanged | 8 |
| 175 | 16M47 | TUBE, handle, conversion | 1 |
| | 3 | | |
| 191 | 113817 | BUMPER | 4 |
| 192 | 100057 | SCREW, cap, hex hd | 4 |
| 193 | 111040 | NUT, lock, insert, nylock, 5/16 | 4 |
| 195 | 16M47 | BRACKET, motor starter | 1 |
| | 4 | | |
| 198 | 24N06 | STARTER, motor assembly | 1 |
| | 4 | | |
| 200 | 119236 | SCREW, plastite | 4 |

▲Danger and Warning labels are available at no cost

DutyMax GH675 Gasoline Engine Parts List

DutyMax GH675 Gasoline Engine Parts List

| Ref. | Torque |
|---|----------------|
|  | 125 ± 5 in-lbs |

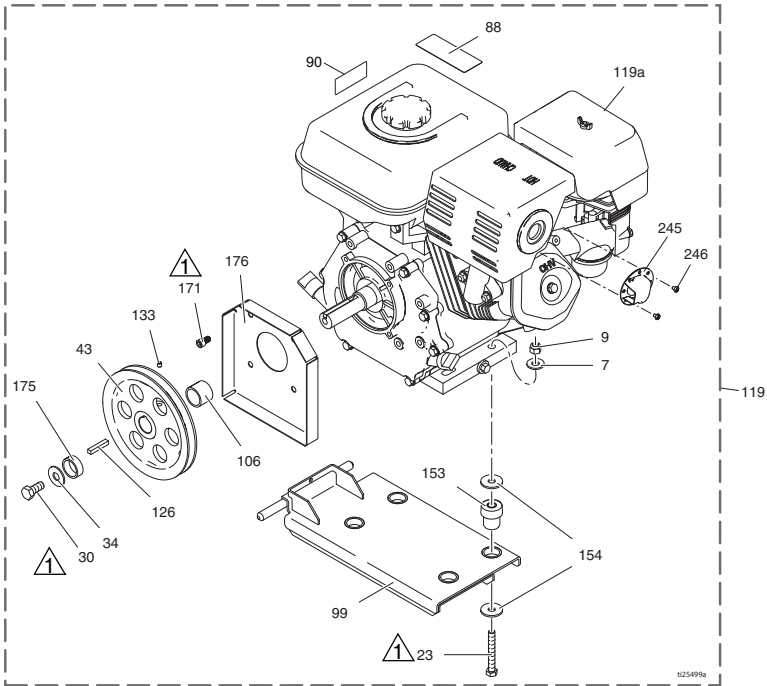

| Ref. | Part | Description | Qty. | Ref. | Part | Description | Qty. |
|------|--------|--------------------------------|------|------|--------|---|------|
| 7 | 100132 | WASHER, flat | 4 | 106 | 15E586 | SLEEVE, shaft, engine | 1 |
| 9 | 101566 | NUT, lock | 4 | 119 | 248945 | KIT, gas engine 9.0 hp (includes all parts listed on this page) | 2 |
| 23 | 106212 | SCREW, cap, hex hd | 4 | 119a | 803900 | ENGINE, gasoline, 9.0 hp (Honda) | 1 |
| 30 | 116645 | SCREW, cap, hex head | 1 | 126 | 119484 | KEY, parallel, square | 1 |
| 34 | 100696 | WASHER, wrought | 1 | 133 | 100002 | SCREW, set | 1 |
| 43 | 119401 | PULLEY | 1 | 153 | 195515 | DAMPENER, motor mount | 4 |
| 44 | 119432 | BELT, V-Grip-notch (not shown) | 1 | 154 | 108851 | WASHER, plain | 8 |
| 88▲ | 194126 | LABEL, warning | 1 | 171 | C20010 | SCREW, cap, socket head | 4 |
| 90▲ | 16Y720 | LABEL, warning, ISO engine | 1 | | | | |
| 99 | 15E583 | BRACKET, mounting, engine | 1 | | | | |

DutyMax GH675 Gasoline Engine Parts List

| Ref. | Part | Description | Qty. |
|------|--------|--------------------------|------|
| 175 | 15E764 | SPACER, shaft, engine | 1 |
| 176 | 15E973 | SHIELD, engine shaft | 1 |
| 245 | 124145 | DEFLECTOR, exhaust | 1 |
| 246 | 128101 | SCREW, tapping | 3 |

▲Danger and Warning labels are available
at no cost

Reservoir and Filter Parts List

Reservoir and Filter Parts List

| Ref. | Torque | Ref. | Torque |
|------|----------------|------|-----------|
| ① | 15 ft-lbs | ③ | 25 ft-lbs |
| ② | 115 ± 5 in-lbs | | |

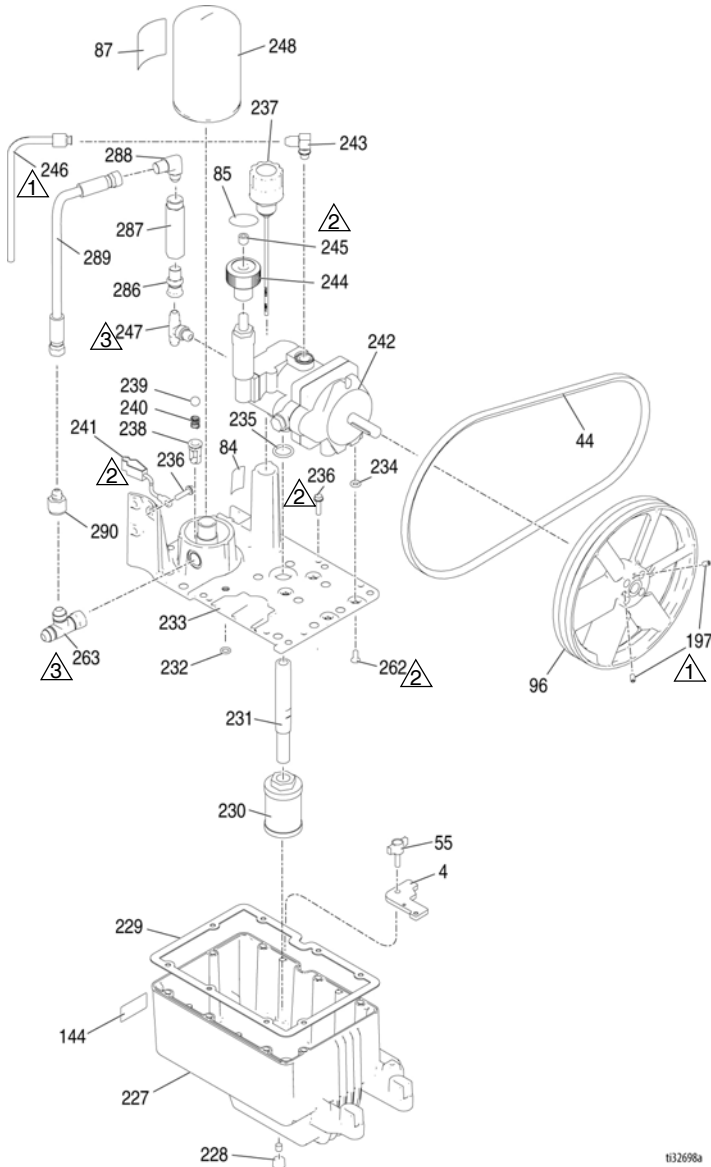

1132698a

Standard Series Reservoir and Filter Parts List

Standard Series Reservoir and Filter Parts List

| Ref. Part | Description | Qty. | Ref. Part | Description | Qty. | |
|-----------|-------------|-------------------------------------|-----------|-------------|----------------------------|---|
| 4 | 15E476 | BRACKET, retainer, motor | 1 | 288 261840 | FITTING, elbow, male | 1 |
| 44 | 116914 | BELT, V, AX42 (EH230DI) | 1 | 289 17V734 | HOSE, hydraulic, 3000 psi | 1 |
| | 119433 | BELT, V, AX41 (GH230DI) | 1 | 290 122398 | FITTING, reducer 6x8 (JIC) | 1 |
| | 125834 | BELT, V, AX48 (EH300DI) | 1 | | | |
| | 119432 | BELT, V, AX44 (GH300DI) | 1 | | | |
| 55 | 17D813 | NUT, hand | 2 | | | |
| 84 | 198585 | LABEL, hydraulic fluid, GH | 1 | | | |
| 85 | 15A464 | LABEL, control | 1 | | | |
| 87 | 189892 | LABEL, Graco | 1 | | | |
| 96 | 15E410 | PULLEY, fan | 1 | | | |
| 144 | 15K440 | LABEL, brand, GH/EH cooling | 1 | | | |
| 197 | 120087 | SCREW, set, 1/4 x 1/2 | 2 | | | |
| 227 | 15J513 | TANK, reservoir, blue | 1 | | | |
| 228 | 101754 | PLUG, pipe | 1 | | | |
| 229 | 120604 | GASKET, reservoir | 1 | | | |
| 230 | 116919 | FILTER | 1 | | | |
| 231 | 15E587 | TUBE, suction | 1 | | | |
| 232 | 154594 | PACKING, o-ring | 1 | | | |
| 233 | 15M056 | COVER, reservoir | 1 | | | |
| 234 | 107188 | PACKING, o-ring | 4 | | | |
| 235 | 156401 | PACKING, o-ring | 1 | | | |
| 236 | 119426 | SCREW, mach, hex washer hd | 11 | | | |
| 237 | 120726 | CAP, breather, filter | 1 | | | |
| 238 | 198841 | RETAINER, ball, pressure bypass | 1 | | | |
| 239 | 100084 | BALL, metallic | 1 | | | |
| 240 | 116967 | SPRING, compression | 1 | | | |
| 241 | 237686 | WIRE, ground assembly w clamp | 1 | | | |
| 242 | 249003 | PUMP, hydraulic (EH/GH230DI) | 1 | | | |
| 243 | 110792 | FITTING, elbow, male, 90° | 1 | | | |
| 244 | 15B438 | KNOB, pressure | 1 | | | |
| 245 | 117560 | SCREW, set, socket head | 1 | | | |
| 246 | 246167 | TUBE, hydraulic, case drain | 1 | | | |
| 247 | 17V730 | FITTING, elbow, hydraulic w/o rings | 1 | | | |
| 248 | 246173 | FILTER, oil, spin on | 1 | | | |
| 262 | 117471 | SCREW, mach, hex, flat head | 4 | | | |
| 263 | 124770 | FITTING, hydraulic | 1 | | | |
| 267 | 243683 | UNION, swivel | 1 | | | |
| 285 | 116618 | MAGNET | 1 | | | |
| 286 | 17V731 | FITTING, 37 degree flare | 1 | | | |
| 287 | 17V732 | VALVE, relief, direct acting, 3000 | 1 | | | |

* Included in Drain Valve Kit 245103

Hydraulic Motor and Displacement Pump Parts

Hydraulic Motor and Displacement Pump Parts List

| Ref. | Torque | Ref. | Torque |
|------|---------------|------|--------------|
| ① | 42 ± 2 ft-lbs | ⑤ | 150 in-lb |
| ② | 15 ft-lbs | ⑥ | 85 ± 4 in-lb |
| ③ | 90-110 in-lbs | ⑦ | 75 ft-lbs |
| ④ | 40 ft-lbs | ⑧ | 25 ft-lbs |

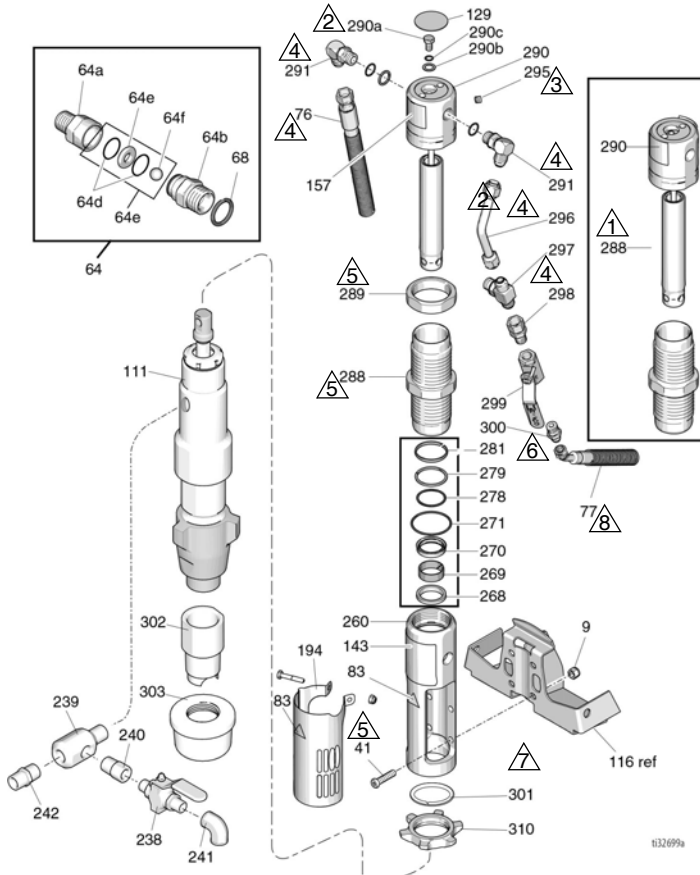

Hydraulic Motor and Displacement Pump Parts

Hydraulic Motor and Displacement Pump Parts List

| Ref. | Part | Description | Qty. | Ref. | Part | Description | Qty. |
|-------|--------|---|------|--|--------|----------------------------|------|
| 9 | 101566 | NUT, lock | 4 | 299 | 117441 | VALVE, ball | 1 |
| 41◆ | 107210 | SCREW | 4 | 300 | 116813 | FITTING, nipple, hydraulic | 1 |
| 64b | 16N462 | HOUSING, ball, check valve | 1 | 301 | 116551 | RING, retaining | 1 |
| 64c | 24M725 | KIT, repair, check valve (includes 64d, 64e, 64f, 68) | 1 | 302 | 17S992 | TUBE, inlet, suction | 1 |
| 64d* | 15B112 | O-RING | 2 | 303 | 237840 | STRAINER | 1 |
| 64e* | 15A968 | SEAT, valve | 1 | ▲ <i>Danger and Warning labels are available at no cost</i> | | | |
| 64f* | 119260 | BALL, ceramic | 1 | ◆ <i>Included in Hydraulic Motor Repair Kit 248977 (EH/GH300).</i> | | | |
| 65 | 109450 | PACKING, o-ring | 1 | + <i>Included in Seal Kit 246174</i> | | | |
| 68* | C20195 | PACKING, o-ring | 1 | * <i>Included in Check Valve Repair Kit 24M725</i> | | | |
| 76 | 15K642 | HOSE, hydraulic, return | 1 | | | | |
| 77 | 15K641 | HOSE, hydraulic, supply | 1 | | | | |
| 83▲◆ | 15H108 | LABEL, warning | 1 | | | | |
| 86 | 193394 | NUT, retaining, GH230/300 | 1 | | | | |
| 111 | 17U996 | PUMP, displacement | 1 | | | | |
| 129◆ | 15B063 | LABEL, warning | 1 | | | | |
| 143 | 17V145 | LABEL, brand, front (EH230DI) | 1 | | | | |
| | 17V147 | LABEL, brand, front (GH230DI) | 1 | | | | |
| 157◆ | 15B804 | LABEL, Graco | 2 | | | | |
| 194 | 24X474 | COVER, shield | 1 | | | | |
| 238 | 237304 | VALVE, ball | 1 | | | | |
| 239 | 15R873 | FITTING, tee | 1 | | | | |
| 240 | 121433 | FITTING, bushing | 1 | | | | |
| 241 | 165472 | ELBOW, pipe | 1 | | | | |
| 242 | 158491 | FITTING, nipple | 1 | | | | |
| 260◆ | 15E243 | MANIFOLD, adapter | 1 | | | | |
| 268◆+ | 117739 | WIPER, rod | 1 | | | | |
| 269◆+ | 112342 | BEARING, rod | 1 | | | | |
| 270◆+ | 112561 | PACKING, block | 1 | | | | |
| 271◆+ | 117283 | PACKING, o-ring | 1 | | | | |
| 278◆+ | 108014 | PACKING, o-ring | 1 | | | | |
| 279◆+ | 178226 | SEAL, piston | 1 | | | | |
| 281◆+ | 178207 | BEARING, piston | 1 | | | | |
| 288◆ | 248991 | SLEEVE, hydraulic | 1 | | | | |
| 289◆ | 15A726 | NUT, jam | 1 | | | | |
| 290◆ | 288755 | KIT, repair, trip rod (includes 129, 278, 279, 281, 282, 295) | 1 | | | | |
| 290a◆ | 106276 | SCREW, cap, hex head | 1 | | | | |
| 290b◆ | 155685 | PACKING, o-ring | 1 | | | | |
| 290c◆ | 178179 | WASHER, sealing | 1 | | | | |
| 291◆ | 117607 | FITTING, elbow std thd | 2 | | | | |
| 295◆ | 100139 | PLUG, pipe | 1 | | | | |
| 296◆ | 15E596 | TUBE, hydraulic, supply | 1 | | | | |
| 297◆ | 117609 | FITTING, tee, branch, str thd | 1 | | | | |
| 298 | 117328 | FITTING, nipple, straight | 1 | | | | |

DutyMax EH/GH675 Spray Gun and Hose

DutyMax EH/GH675 Spray Gun and Hose Parts List

| Ref. | Part No. | Description | Qty. |
|------|----------|--------------------------------------|------|
| 225a | 159238 | FITTING, nipple, pipe, rdcg | 2 |
| 225b | H73810 | HOSE, cpld, 3/8 in. x 10ft 7250 wp | 1 |
| 225d | 17V677 | KIT, accessory, gun | 1 |
| | 24P834 | SWIVEL, straight | 1 |
| 225f | H75050 | HOSE, cpld, 1/2 in. x 50 ft, 7250 wp | 1 |

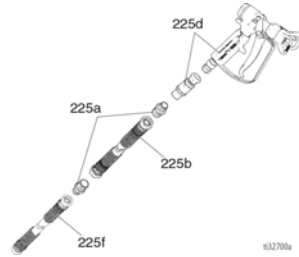

EH Technical Data

| DutyMax EH675 | | |
|---|------------------------------------|-----------------------------------|
| | US | Metric |
| Maximum fluid working pressure | 6750 psi | 46.5 MPa, 465 bar |
| Hydraulic reservoir capacity | 1.25 gallons | 4.75 liters |
| Motor | 7.5 HP | 5.5 kW |
| Voltage, Amperage Frequency Phase | 400 VAC, 11.0 A, 50 Hz, 3 phase | 400 VAC, 11.0 A 50 Hz, 3 phase |
| Maximum tip size | 0.33 | |
| Maximum free-flow delivery | 1.4 gpm | 5.3 l/min |
| Hose connection | 1/2 npsm (f) | |
| Cycles per gallon/liter | 101 cpg | 26.6 cpl |
| Sound Levels (Measured at maximum normal load conditions) | | |
| Sound pressure (per ISO9614) | 80 dBa | |
| Sound power (per ISO9614) | 95 dBa | |
| Inlet/Outlet Sizes | | |
| Fluid inlet size in. | 1 1/4 - 1 1/2 NPT (m) | |
| Fluid outlet size in. | 1/2 npt (m) | |
| Weight | | |
| | 230 lb. | 104 kg |
| Width | | |
| | 26.5 in. | 67 cm |
| Length (Handle bar retracted) | | |
| | 47.7 in. | 121 cm |
| Height (Handle bar retracted) | | |
| | 35.5 in. | 90 cm |

NOTE: Under voltage release coil in motor starter for EH675 will not energize if voltage is less than 85% of listed voltage in Technical Data table.

Under voltage release coil in motor starter for EH675 will de-energize and sprayer will stop if voltage drops to 85% of rated nominal voltage. Voltage will need to be increased and sprayer will need to be restarted.

NOTE: To operate the EH675 sprayer with a generator, the generator must be sized for 5 kW output (minimum).

GH Technical Data

| DutyMax GH675 | | |
|---|-------------------|-------------------|
| | US | Metric |
| Maximum fluid working pressure | 6750 psi | 46.5 MPa, 465 bar |
| Hydraulic reservoir capacity | 1.25 gallons | 4.75 liters |
| Maximum hydraulic pressure | 1855 psi | 12.8 MPa, 128 bar |
| Engine | 270 cc (9.0 HP) | |
| Maximum tip size | .033 | |
| Maximum free-flow delivery | 1.4 gpm | 5.3 l/min |
| Hose connection | 1/2 npsm (m) | |
| Sound Levels (Measured at maximum normal load conditions) | | |
| Maximum sound pressure (per ISO9614) | 96 dBa | |
| Maximum sound power (per ISO9614) | 110 dBa | |
| Inlet/Outlet Sizes | | |
| Fluid inlet size | 1 1/4 - 1 1/2 NPT | |
| Fluid outlet size | 1/2 NPT (f) | |
| Weight | | |
| | 207lbs | 94 kg |
| Width | | |
| | 26.5 in. | 67 cm |
| Length | | |
| | 47.7 in. | 121 cm |
| Height (Handle bar retracted) | | |
| | 35.5 in. | 90 cm |

Graco Standard Warranty

Graco warrants all equipment referenced in this document which is manufactured by Graco and bearing its name to be free from defects in material and workmanship on the date of sale to the original purchaser for use. With the exception of any special, extended, or limited warranty published by Graco, Graco will, for a period of twelve months from the date of sale, repair or replace any part of the equipment determined by Graco to be defective. This warranty applies only when the equipment is installed, operated and maintained in accordance with Graco's written recommendations.

This warranty does not cover, and Graco shall not be liable for general wear and tear, or any malfunction, damage or wear caused by faulty installation, misapplication, abrasion, corrosion, inadequate or improper maintenance, negligence, accident, tampering, or substitution of non-Graco component parts. Nor shall Graco be liable for malfunction, damage or wear caused by the incompatibility of Graco equipment with structures, accessories, equipment or materials not supplied by Graco, or the improper design, manufacture, installation, operation or maintenance of structures, accessories, equipment or materials not supplied by Graco.

This warranty is conditioned upon the prepaid return of the equipment claimed to be defective to an authorized Graco distributor for verification of the claimed defect. If the claimed defect is verified, Graco will repair or replace free of charge any defective parts. The equipment will be returned to the original purchaser transportation prepaid. If inspection of the equipment does not disclose any defect in material or workmanship, repairs will be made at a reasonable charge, which charges may include the costs of parts, labor, and transportation.

THIS WARRANTY IS EXCLUSIVE, AND IS IN LIEU OF ANY OTHER WARRANTIES, EXPRESS OR IMPLIED, INCLUDING BUT NOT LIMITED TO WARRANTY OF MERCHANTABILITY OR WARRANTY OF FITNESS FOR A PARTICULAR PURPOSE.

Graco's sole obligation and buyer's sole remedy for any breach of warranty shall be as set forth above. The buyer agrees that no other remedy (including, but not limited to, incidental or consequential damages for lost profits, lost sales, injury to person or property, or any other incidental or consequential loss) shall be available. Any action for breach of warranty must be brought within two (2) years of the date of sale.

GRACO MAKES NO WARRANTY, AND DISCLAIMS ALL IMPLIED WARRANTIES OF MERCHANTABILITY AND FITNESS FOR A PARTICULAR PURPOSE, IN CONNECTION WITH ACCESSORIES, EQUIPMENT, MATERIALS OR COMPONENTS SOLD BUT NOT MANUFACTURED BY GRACO. These items sold, but not manufactured by Graco (such as electric motors, switches, hose, etc.), are subject to the warranty, if any, of their manufacturer. Graco will provide purchaser with reasonable assistance in making any claim for breach of these warranties.

In no event will Graco be liable for indirect, incidental, special or consequential damages resulting from Graco supplying equipment hereunder, or the furnishing, performance, or use of any products or other goods sold hereto, whether due to a breach of contract, breach of warranty, the negligence of Graco, or otherwise.

FOR GRACO CANADA CUSTOMERS

The Parties acknowledge that they have required that the present document, as well as all documents, notices and legal proceedings entered into, given or instituted pursuant hereto or relating directly or indirectly hereto, be drawn up in English. Les parties reconnaissent avoir convenu que la rédaction du présente document sera en Anglais, ainsi que tous documents, avis et procédures judiciaires exécutés, donnés ou intentés, à la suite de ou en rapport, directement ou indirectement, avec les procédures concernées.

Graco Information

For the latest information about Graco products, visit www.graco.com.

For patent information, see www.graco.com/patents.

TO PLACE AN ORDER, contact your Graco distributor or call 1-800-690-2894 to identify the nearest distributor.

All written and visual data contained in this document reflects the latest product information available at the time of publication.

Graco reserves the right to make changes at any time without notice.

Original instructions. This manual contains English. MM 3A5369

Graco Headquarters: Minneapolis
International Offices: Belgium, China, Japan, Korea

GRACO INC. AND SUBSIDIARIES • P.O. BOX 1441 • MINNEAPOLIS MN 55440-1441 • USA

Copyright 2017, Graco Inc. All Graco manufacturing locations are registered to ISO 9001.

www.graco.com
Revision A, February 2018