

## FinishPro™ HVLP 7.0/9.0/9.5

313406L

EN

For portable spray applications of fine finish coatings. For professional use only.  
Not approved for use in European explosive atmosphere locations.

**120 Vac Models: 256847, 256848, 256849**

**240 Vac Models: 256851, 256852, 256853**

*Maximum Working Pressure: 10 psi (0,07 MPa, 0.7 bar)*



### Important Safety Instructions

Read all warnings and instructions in this manual. Save these instructions.

US Patent No.: 7,950,598, 7,971,806

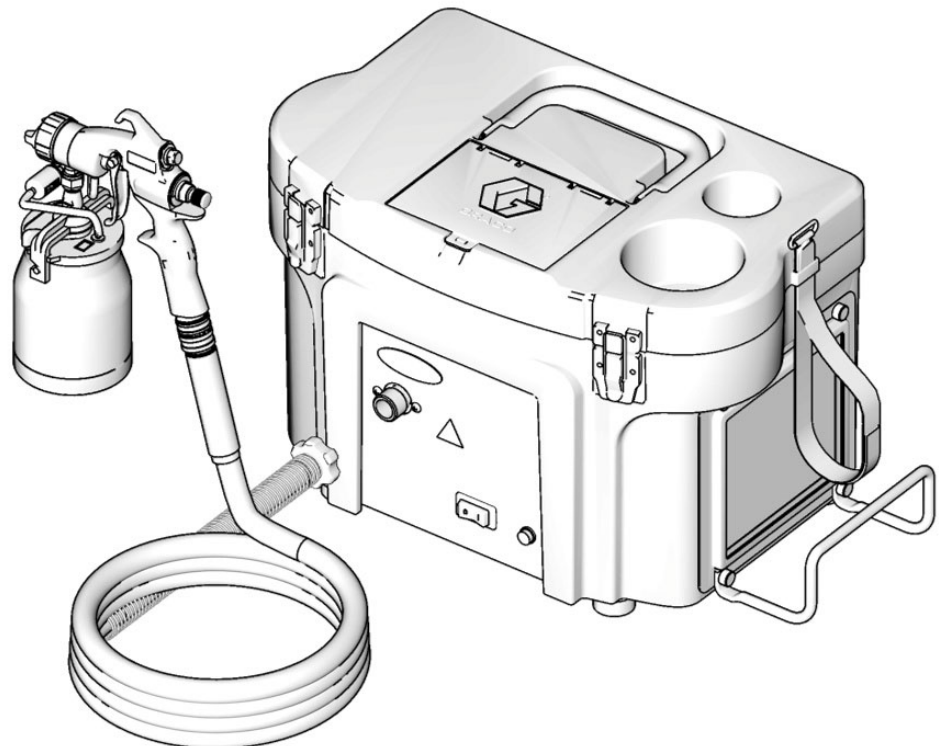

# Table of Contents

<b>Warnings</b> .....	<b>3</b>	<b>Turbine Replacement</b> .....	<b>11</b>
Grounding and Electric Requirements .....	5	<b>Wiring Diagrams</b> .....	<b>12</b>
<b>Component Identification</b> .....	<b>6</b>	<b>Technical Data</b> .....	<b>13</b>
<b>Setup</b> .....	<b>7</b>	<b>Parts</b> .....	<b>14</b>
Fluid Preparation .....	7	<b>Parts List</b> .....	<b>15</b>
Connect Fluid and Air Supply .....	7	<b>Parts Drawing</b> .....	<b>16</b>
Pressure Relief Procedure .....	7	<b>Parts List</b> .....	<b>17</b>
Operation Tips .....	7	<b>Graco Standard Warranty</b> .....	<b>18</b>
<b>Maintenance</b> .....	<b>8</b>		
<b>Troubleshooting</b> .....	<b>9</b>		
<b>Repair</b> .....	<b>10</b>		
Sprayer Disassembly .....	10		
Sprayer Assembly .....	10		

# Warnings

The following warnings are for the setup, use, grounding, maintenance and repair of this equipment. The exclamation point symbol alerts you to a general warning and the hazard symbol refers to procedure-specific risks. Refer back to these warnings. Additional, product-specific warnings may be found throughout the body of this manual where applicable.

## WARNING



### GROUNDING

This product must be grounded. In the event of an electrical short circuit, grounding reduces the risk of electric shock by providing an escape wire for the electric current. This product is equipped with a cord having a grounding wire with an appropriate grounding plug. The plug must be plugged into an outlet that is properly installed and grounded in accordance with all local codes and ordinances.

- Improper installation of the grounding plug is able to result in a risk of electric shock.
- When repair or replacement of the cord or plug is required, do not connect the grounding wire to either flat blade terminal.
- The wire with insulation having an outer surface that is green with or without yellow stripes is the grounding wire.
- Check with a qualified electrician or serviceman when the grounding instructions are not completely understood, or when in doubt as to whether the product is properly grounded.
- Do not modify the plug provided; if it does not fit the outlet, have the proper outlet installed by a qualified electrician.
- This product is for use on a nominal 120V circuit and has a grounding plug similar to the plug illustrated in the figure below.

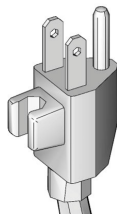









- Only connect the product to an outlet having the same configuration as the plug.
- Do not use an adapter with this product.

#### Extension Cords:

- Use only a 3-wire extension cord that has a 3-blade grounding plug and a 3-slot receptacle that accepts the plug on the product.
- Make sure your extension cord is not damaged. If an extension cord is necessary, use 12 AWG (2.5 mm<sup>2</sup>) minimum to carry the current that the product draws.
- An undersized cord results in a drop in line voltage and loss of power and overheating.

**WARNING**

  	<p><b>FIRE AND EXPLOSION HAZARD</b></p> <p>Flammable fumes, such as solvent and paint fumes, in work area can ignite or explode. To help prevent fire and explosion:</p> <ul style="list-style-type: none"> <li>• Do not spray flammable or combustible materials near an open flame or sources of ignition such as cigarettes, motors, and electrical equipment.</li> <li>• Paint or solvent flowing through the equipment is able to result in static electricity. Static electricity creates a risk of fire or explosion in the presence of paint or solvent fumes. All parts of the spray system, including the pump, hose assembly, spray gun, and objects in and around the spray area shall be properly grounded to protect against static discharge and sparks. Use Graco conductive or grounded high-pressure airless paint sprayer hoses.</li> <li>• Verify that all containers and collection systems are grounded to prevent static discharge.</li> <li>• Connect to a grounded outlet and use grounded extensions cords. Do not use a 3-to-2 adapter.</li> <li>• Do not use a paint or a solvent containing halogenated hydrocarbons.</li> <li>• Keep spray area well-ventilated. Keep a good supply of fresh air moving through the area. Keep pump assembly in a well ventilated area. Do not spray pump assembly.</li> <li>• Do not smoke in the spray area.</li> <li>• Do not operate light switches, engines, or similar spark producing products in the spray area.</li> <li>• Keep area clean and free of paint or solvent containers, rags, and other flammable materials.</li> <li>• Know the contents of the paints and solvents being sprayed. Read all Material Safety Data Sheets (MSDS) and container labels provided with the paints and solvents. Follow the paint and solvents manufacturer's safety instructions.</li> <li>• Fire extinguisher equipment shall be present and working.</li> <li>• Sprayer generates sparks. When flammable liquid is used in or near the sprayer or for flushing or cleaning, keep sprayer at least 20 feet (6 m) away from explosive vapors.</li> </ul>
 	<p><b>ELECTRIC SHOCK HAZARD</b></p> <p>Improper grounding, setup, or usage of the system can cause electric shock.</p> <ul style="list-style-type: none"> <li>• Turn off and disconnect power cord before servicing equipment.</li> <li>• Use only grounded electrical outlets.</li> <li>• Use only 3-wire extension cords.</li> <li>• Ensure ground prongs are intact on sprayer and extension cords.</li> <li>• Do not expose to rain. Store indoors.</li> </ul>
	<p><b>TOXIC FLUID OR FUMES HAZARD</b></p> <p>Toxic fluids or fumes can cause serious injury or death if splashed in the eyes or on skin, inhaled, or swallowed.</p> <ul style="list-style-type: none"> <li>• Read MSDS's to know the specific hazards of the fluids you are using.</li> <li>• Store hazardous fluid in approved containers, and dispose of it according to applicable guidelines.</li> </ul>
	<p><b>EQUIPMENT MISUSE HAZARD</b></p> <p>Misuse can cause death or serious injury.</p> <ul style="list-style-type: none"> <li>• Always wear appropriate gloves, eye protection, and a respirator or mask when painting.</li> <li>• Do not operate or spray near children. Keep children away from equipment at all times.</li> <li>• Do not overreach or stand on an unstable support. Keep effective footing and balance at all times.</li> <li>• Stay alert and watch what you are doing.</li> <li>• Do not operate the unit when fatigued or under the influence of drugs or alcohol.</li> <li>• Do not kink or over-bend the hose.</li> <li>• Do not expose the hose to temperatures or to pressures in excess of those specified by Graco.</li> <li>• Do not use the hose as a strength member to pull or lift the equipment.</li> </ul>
	<p><b>PRESSURIZED ALUMINUM PARTS HAZARD</b></p> <p>Do not use 1,1,1-trichloroethane, methylene chloride, other halogenated hydrocarbon solvents or fluids containing such solvents in pressurized aluminum equipment. Such use can cause serious chemical reaction and equipment rupture, and result in death, serious injury, and property damage.</p>
	<p><b>PERSONAL PROTECTIVE EQUIPMENT</b></p> <p>You must wear appropriate protective equipment when operating, servicing, or when in the operating area of the equipment to help protect you from serious injury, including eye injury, inhalation of toxic fumes, burns, and hearing loss. This equipment includes but is not limited to:</p> <ul style="list-style-type: none"> <li>• Protective eyewear and hearing protection</li> <li>• Gloves, clothing and respirator as recommended by the fluid and solvent manufacturer</li> </ul>

 **WARNING**

**CALIFORNIA PROPOSITION 65**

The engine exhaust from this product contains a chemical known to the State of California to cause cancer, birth defects or other reproductive harm.

## Grounding and Electric Requirements

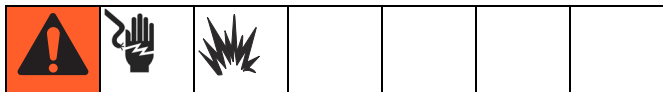

This equipment requires a 120 Vac, 60 Hz, 15A circuit, with a grounding receptacle.

Use 3-wire, 12 awg, 50 ft (15 m) or shorter, extension cords with ground prong.

Do not alter the ground prong or use an adapter.

### Sprayer Components Table

Sprayer	Model	Hose	Gun	Fluid Sets
FinishPro 7.0	256847, 256851	30-ft	256855 <i>EDGE</i>	#3
FinishPro 9.0	256848, 256852	30-ft	256855 <i>EDGE</i>	#3, #4
FinishPro 9.5	256849, 256853	30-ft and 4-ft	256855 <i>EDGE</i>	#2, #3, #4

# Component Identification

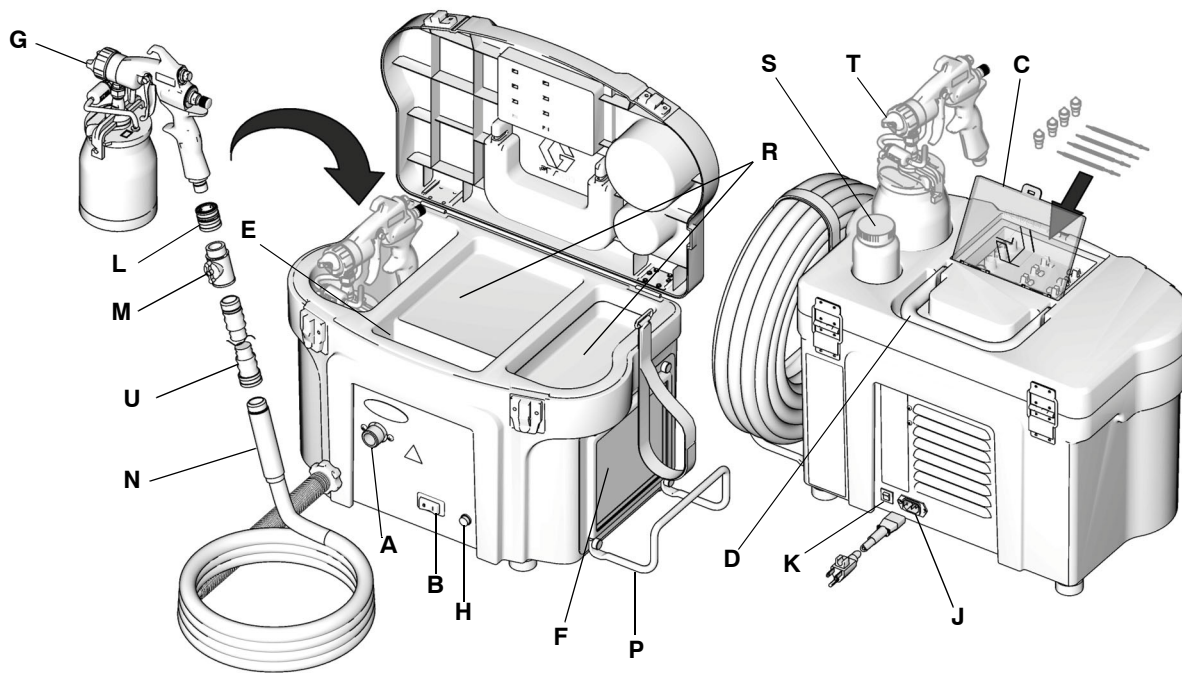

ti12858a

Item	Description
A	Sprayer air outlet HVLV connector for air supply to HVLV spray Gun
B	Sprayer power switch On/Off switch for sprayer motor
C	Fluid storage compartment Provides storage for up to four fluid sets
D	Sprayer handle Folds flat for minimum storage space
E	Power cord storage Provides storage for power cord
F	Air filters (pre-filter and main) Provides filtered air for spray gun and motor
G	Spray gun Graco <i>EDGE</i> <sup>™</sup> spray gun with <i>EasyGlide</i> <sup>™</sup> trigger
H	Air filter indicator Lights when air filter needs to be cleaned or replaced
J	Connector and power cord Provides power for sprayer (power cord provided with sprayer)

Item	Description
K	Resettable circuit breaker Provides protection for motor
L	Quick connect Enables quick connection to spray gun
M	Air valve Provides FinishPro 9.0 and 9.5 sprayers ability to shut off air to spray gun
N	Air hose Hose, 30 ft x 1 in., that connects spray gun and sprayer.
P	Hose wrap Provides storage for air hose when air hose is not in use
R	Storage tray Provides extra storage
S	Cleaning cup holder Provides storage for cleaning cup
T	<i>EDGE</i> spray gun holder Provides external storage for spray gun
U	Hose, 4-ft Allows increased flexibility for the FinishPro 9.5

# Setup

## Fluid Preparation

- Strain fluids before you spray. This includes color, reducers and hardeners.
- Use a slower drying reducer or thinner to compensate for the faster drying time caused by the warm air of the turbine. Do not over reduce
- Sprayer performance varies with the viscosity of the material sprayed and the length of the hose. To prevent pressure drop, use hose supplied with sprayer.
- Most material manufacturers provide recommendations for their materials. Follow these recommendations.

## Connect Fluid and Air Supply

### Spray Gun with Siphon Cup

1. Connect air hose to sprayer. Hand tighten.

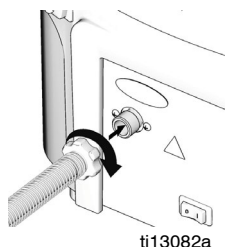

2. Connect air hose from sprayer to inlet fitting of gun.

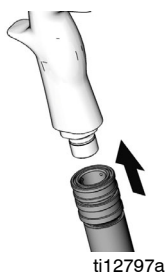

3. Fill cup 3/4 full. Install cover. Latch the gun cup cover to secure it to siphon cup. See HVLP *EDGE* Gun manual 313317 for operation instructions.



## Connect to Electric Supply

Plug sprayer power cord into grounded outlet. Grounding and Electric Requirements, page 5.

## Pressure Relief Procedure

<p>The spray gun siphon cup is pressurized by the gun air supply. To reduce the risk of serious injury from pressurized fluid or accidental spray from gun, always turn off the air supply to the spray gun before removing the siphon cup.</p>						

1. Turn off sprayer.
2. Unplug sprayer.
3. Unlatch cup cover; loosen or remove cup from cover to relieve pressure.

## Operation Tips

<p>Sparks can be expected during normal operation of motor. These sparks can ignite fumes from flammable liquids, dust particles, and other flammable substances in the spray area.</p> <ul style="list-style-type: none"> <li>• Use additional hose if necessary, and ensure the sprayer is operated in clean, dry, well ventilated area.</li> <li>• Never use sprayer inside spray booth.</li> </ul>						

- Turn sprayer on a few minutes before spraying to allow warm-up.
- Ensure sprayer filter is clean before operating. Clean filter, page 8.
- To adjust spray gun pattern, see HVLP *EDGE* Gun manual 313317.
- To get proper adhesion, ensure surface is completely clean.
- Always spray with the least amount of pressure required to provide the desired spray pattern and rate of application. Spraying at pressures higher than necessary wastes paint and can result in an orange peel finish.

# Maintenance

The sprayer system is lifetime lubricated. The only maintenance required is filter cleaning and replacement.

## Filter Operation

The sprayer filter must be clean at all times to provide sufficient air flow to cool the motor and atomize the fluid.

The sprayer has an air filter indicator light on the front panel. The indicator light illuminates if the filter is clogged or has low airflow.

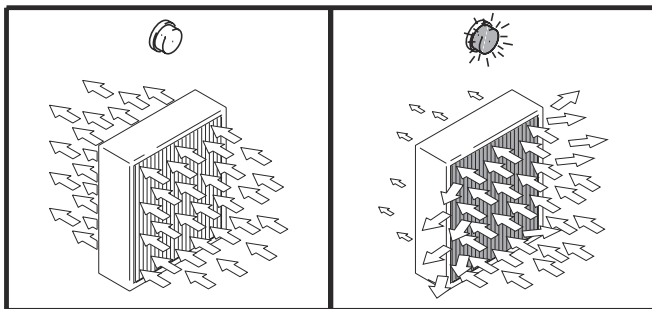

ti8049a

## Cleaning Filter

1. Turn off and unplug sprayer.
2. Loosen four screws (18), remove filter retainer (17) and pre-filter (20).
3. Remove main filter (21) and clean using one of the following methods:
  - Tap filter gently on flat surface, dirty side down.
  - Direct, compressed air 100 psi (7 bar, 70 MPa) (maximum) through filter panel in the opposite direction of arrows on side of filter from the clean side to the dirty side.
  - Soak filter for 15 minutes in water and mild detergent. Rinse filter until clean. Air dry.

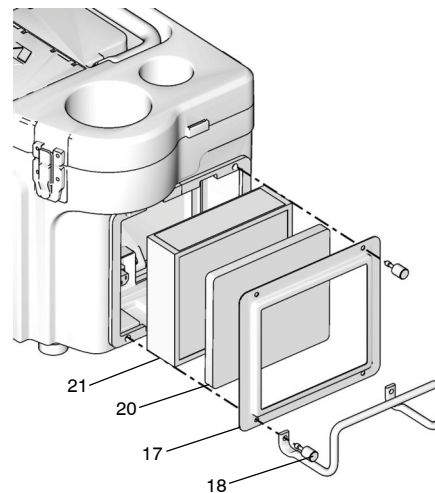
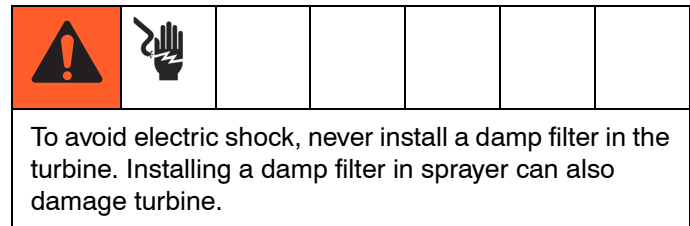

ti13061a



# Troubleshooting

Problem	Cause	Solution
No fluid delivery	No material, no remote cup pressurization, hose or pickup tube clogged	Check cup for material
		Check for leaks at the container gasket (1-quart remote cup cover). Tighten cover if loose.
		Check air flow (approximately 1/4 CFM) from male quick-disconnect at Compact outlet.
		Turn pressure regulator clockwise. Look for pressure on gauge. (If no pressure on gauge, check air line fittings.)
		Check hole in 1-quart remote cup cover at needle valve for blockage or dirt. Clean if necessary.
		Check for obstructions.
		Check if fluid pickup tube is loose. Tighten.
		Blow out and clear material hose.
		Clean check valve. See manual 313317
Sprayer not starting	No power	Check outlet for power. Cycle red rocker switch.
		Check that correct IEC (modular) cord is used and plugged in.
		Check circuit breaker (38). Push to reset.
Poor atomization	Dirty filter	Clean filter and replace as necessary.
	Extension cord too long	Extension cord must be 3-wire, 12 AWG, 50 ft (15 m) or shorter.
	Hose too long	Replace with shorter hose. See Graco Fine Finish Solutions brochure 300564, for hose part numbers.
Circuit breaker trips	Filter clogged	Clean filter and replace as necessary
	High ambient temperature	Move sprayer to cooler area.
	Excessive current draw	Return to authorized service center.

# Repair

## Sprayer Disassembly

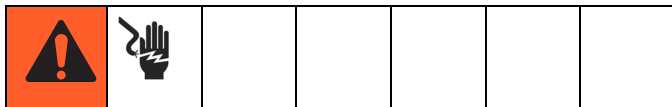

To avoid injury, including electric shock turn off sprayer and unplug power cord before performing any repair procedures on the turbine.

1. Remove four thumbscrews (18) and remove filter retainer (17), prefilter (20) and main filter (16). Parts, page 14.

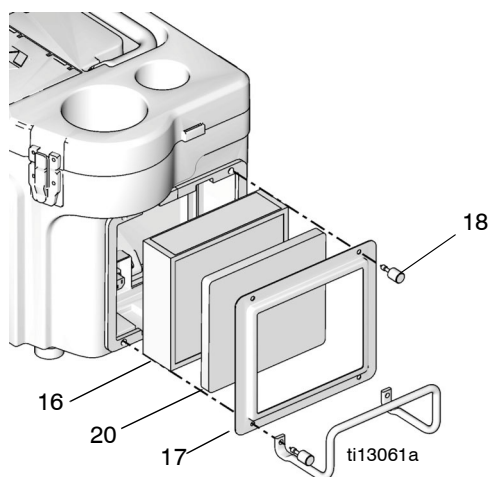

2. Remove two screws (101) and inlet plug (61) from HVLP box (1). Remove three motor wire connectors from inlet plug (61).

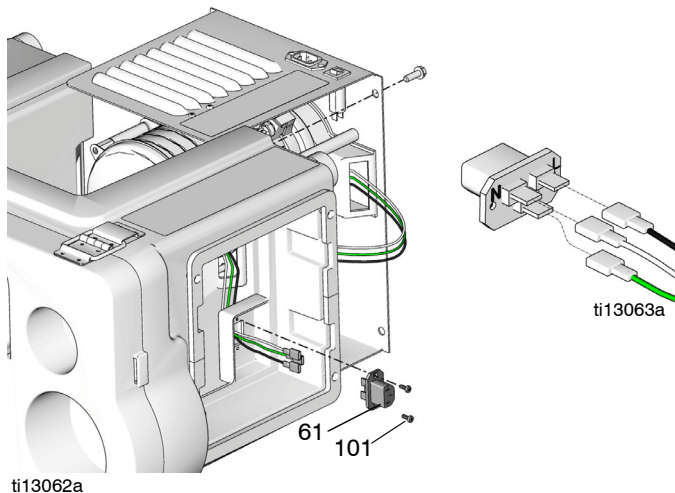

3. Place sprayer upside down. Remove four screws (77) from sprayer base plate (2).

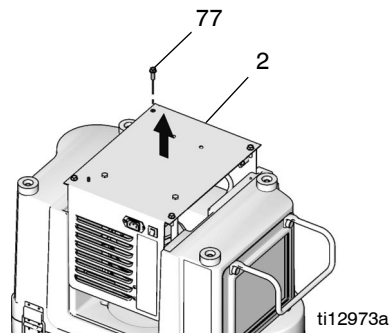

4. Pull up sprayer base plate and attached parts. Thread motor wires that connected to inlet plug through access in HVLP box.
5. Repair or replace any required parts.

## Sprayer Assembly

1. Replace duct gaskets (59, 60) and any other damaged or worn parts. Replace circuit breaker (32), if it has cycled. Remove residual adhesive from previous gaskets by wiping any sticky surfaces with mineral spirits solvent (also called white spirit). Let solvent evaporate thoroughly before installing replacement gasket.
2. Use an adjustable square with blade running full length of longest side of duct (22), to position duct perpendicular to the base (2). Hold duct in place to keep duct perpendicular to base edge and carefully remove square.
3. Turn sprayer upside-down. Carefully slip base plate and attached parts down into HVLP box (1). **NOTE:** Be sure duct to maintain duct alignment.
4. Thread motor wires that connect with plug (61) through access port in HVLP box.
5. Use four screws (77) to secure base plate to HVLP box (1). Use an adjustable clamp over the outside of HVLP box (1) to align screw holes if necessary.
6. Install three motor wire connectors onto plug (61). Install plug (61) with two screws (101) into HVLP box (1).
7. Install filter gaskets (19), main filter (16) with arrow facing into HVLP box (1), pre-filter (20), filter retainer (17), and hose rack (35) with four thumbscrews (18).

# Turbine Replacement

Refer to Parts Drawing, page 14.

1. Follow Sprayer Disassembly procedure, page 10.
2. Remove gasket (21).
3. Remove three screws (14) from spacer (38).
4. Remove plate (21) and three spacers (83).
5. Remove motor wires from spade connectors.
6. Rotate motor (11) from outlet fitting (29) and lift up from spacers (41).
7. Install new gaskets (21, 23, 24, 59 and 60). Use mineral spirits solvent (also called white spirit) to remove any adhesive remaining from old gaskets.
8. Reassemble turbine. Use an adjustable square with the blade running the full length of the longest side of the duct (22) to position duct perpendicular to base (2). Hold duct in place and carefully remove square to keep duct perpendicular to edge of base. With sprayer upside down, carefully slip base plate and attached parts (see page 16) down into HVLP box (1). **NOTE:** Be sure to maintain duct alignment.
9. Connect ground wire to motor housing.
10. Reconnect wires. Attach plug (61) to HVLP box with two screws (101).

# Wiring Diagrams

## USA

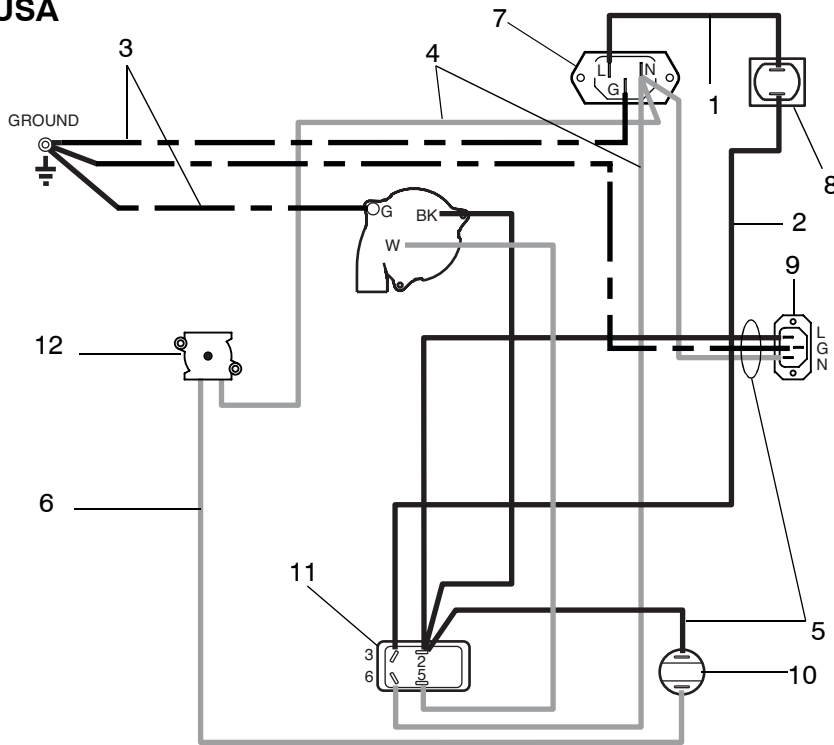

Ref. Part	Description	Qty
1	244273 Conductor, BK	1
2	15W486 Conductor, BK	1
3	15W485 Conductor, G/Y	1
4	15W484 Conductor, W	1
5	257333 Conductor, W, BK, G	1
6	240256 Conductor, W	1
7	114064 Plug, inlet	1
8	114403 Circuit Breaker, 15A	1
9	15V923 Plug, outlet, CompPack	1
10	114280 Light, indicator, 120V	1
11	120660 Switch, rocker	1
12	114279 Sensor, pressure	1

ti12765a

## International

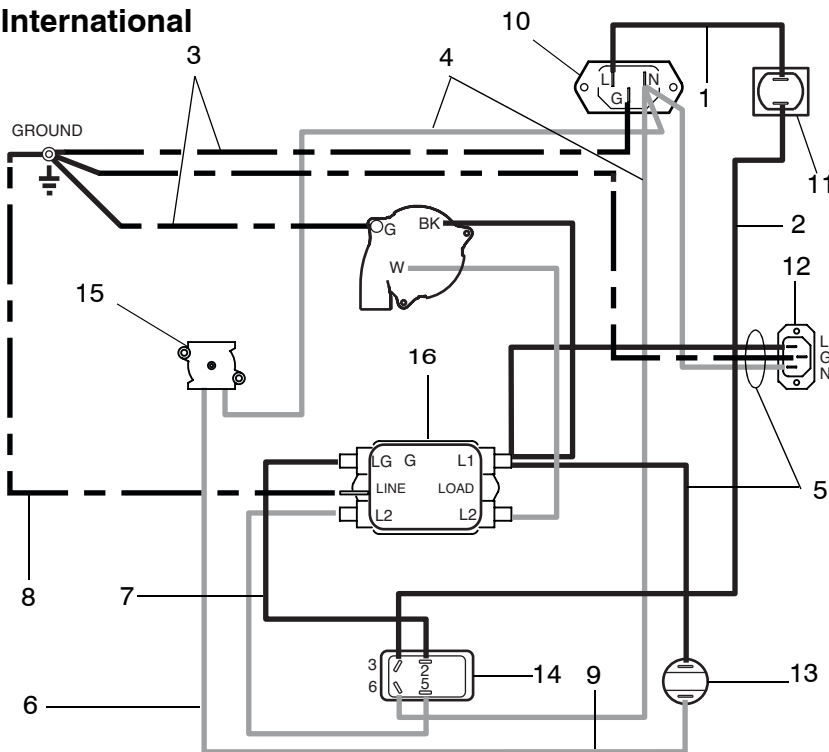

Ref. Part	Description	Qty
1	244273 Conductor, BK	1
2	15W486 Conductor, BK	1
3	15W485 Conductor, G/Y	1
4	15W484 Conductor, W	1
5	257333 Conductor, W, BK, G	1
6	15W488 Conductor, W	1
7	15W487 Conductor, BK	1
8	240558 Conductor, G/Y	1
9	240256 Conductor, W	1
10	114064 Plug, inlet	1
11	16A348 Circuit Breaker, 10A	1
12	15V923 Plug, outlet, CompPack	1
13	114286 Light, Indicator, 240V	1
14	120660 Switch, rocker	1
15	114279 Sensor, pressure	1
16	116168 Filter, suppression	1

ti12770a

# Technical Data

## 120 Vac, 60 Hz

	<b>Ampere</b>	<b>Watts</b>	<b>Maximum Hose Length ft (m)</b>	<b>Sprayer Weight lb (kg)</b>	<b>Total Weight lb (kg)</b>	<b>Sound Power*</b>	<b>Sound Pressure*</b>
FinishPro 7.0	11.0	200	40 (12,2)	28 (12,7)	38 (17,2)	94.9 dBa	82 dBa
FinishPro 9.0	11.0	250	60 (18,3)	29 (13,2)	39 (17,7)	95.9 dBa	83 dBa
FinishPro 9.5	13.6	300	60 (18,3)	30 (13,6)	40 (18,1)	96.3 dBa	83.4 dBa

## 240 Vac, 50 Hz

	<b>Ampere</b>	<b>Watts</b>	<b>Maximum Hose Length ft (m)</b>	<b>Sprayer Weight lb (kg)</b>	<b>Total Weight lb (kg)</b>	<b>Sound Power*</b>	<b>Sound Pressure*</b>
FinishPro 7.0	5,40	200	40 (12,2)	28 (12,7)	38 (17,2)	94.9 dBa	82 dBa
FinishPro 9.0	5,93	250	60 (18,3)	29 (13,2)	39 (17,7)	95.9 dBa	83 dBa
FinishPro 9.5	7,07	300	60 (18,3)	30 (13,6)	40 (18,1)	96.3 dBa	83.4 dBa

\* Sound Power and Sound Pressure are measured at  
1 meter per ISO 3744



# Parts List

Models 256847, 256848, 256849, 256851, 256852, 256853

Ref.	Part	Description	Qty.	Ref.	Part	Description	Qty.
1	277934	BOX, HVLP	1		240065	FinishPro 9.5	1
3	24B055	COVER, HVLP (includes 6)	1	61	15V923	PLUG, inlet	1
4	15V791	HANDLE	1	62 ▲	15W100	LABEL, safety	1
6	15V771	LID, accessory	1	63 ▲	15W223	LABEL, safety	1
8	15V926	LATCH	2	77	15W359	SCREW, mach, hex, washer hd	8
13	257159	HOSE, air, 30 ft, black	1	87	15W635	LABEL, FinishPro, HVLP	1
16	240273	FILTER, main	1	88		LABEL, FinishPro, HVLP	
17	15W794	RETAINER, filter	1		15W636	LABEL, FinishPro, HVLP 7.0	1
18	15W897	SCREW, captive	4		15W637	LABEL, FinishPro, HVLP 9.0	1
19	15W217	GASKET, filter	2		15W638	LABEL, FinishPro, HVLP 9.5	1
20	15W909	FILTER, foam	1	89	257161	HOSE, 4 ft, FinishPro 9.5	1
25	113817	BUMPER	4	100	15V927	HINGE	2
30	15W505	SCREW, mach, phillips pan hd	2	101	117317	SCREW, plastite, pan hd	2
33	256855	GUN, HVLP, with cup	1	102	15X227	SCREW, cap, hex hd	2
34	114271	STRAP, retaining	1	103	102040	NUT, lock, hex	2
35	15V862	HOSE, rack	1	104	116234	BOTTLE	1
49		VALVE, air control		105	M70402	QUICK DISCONNECT	1
		FinishPro 7.0 (not included)					
	240065	FinishPro 9.0	1				

▲ Extra Danger and Warning labels are available for free.

# Parts Drawing

Models 256847, 256848, 256849, 256851, 256852, 256853

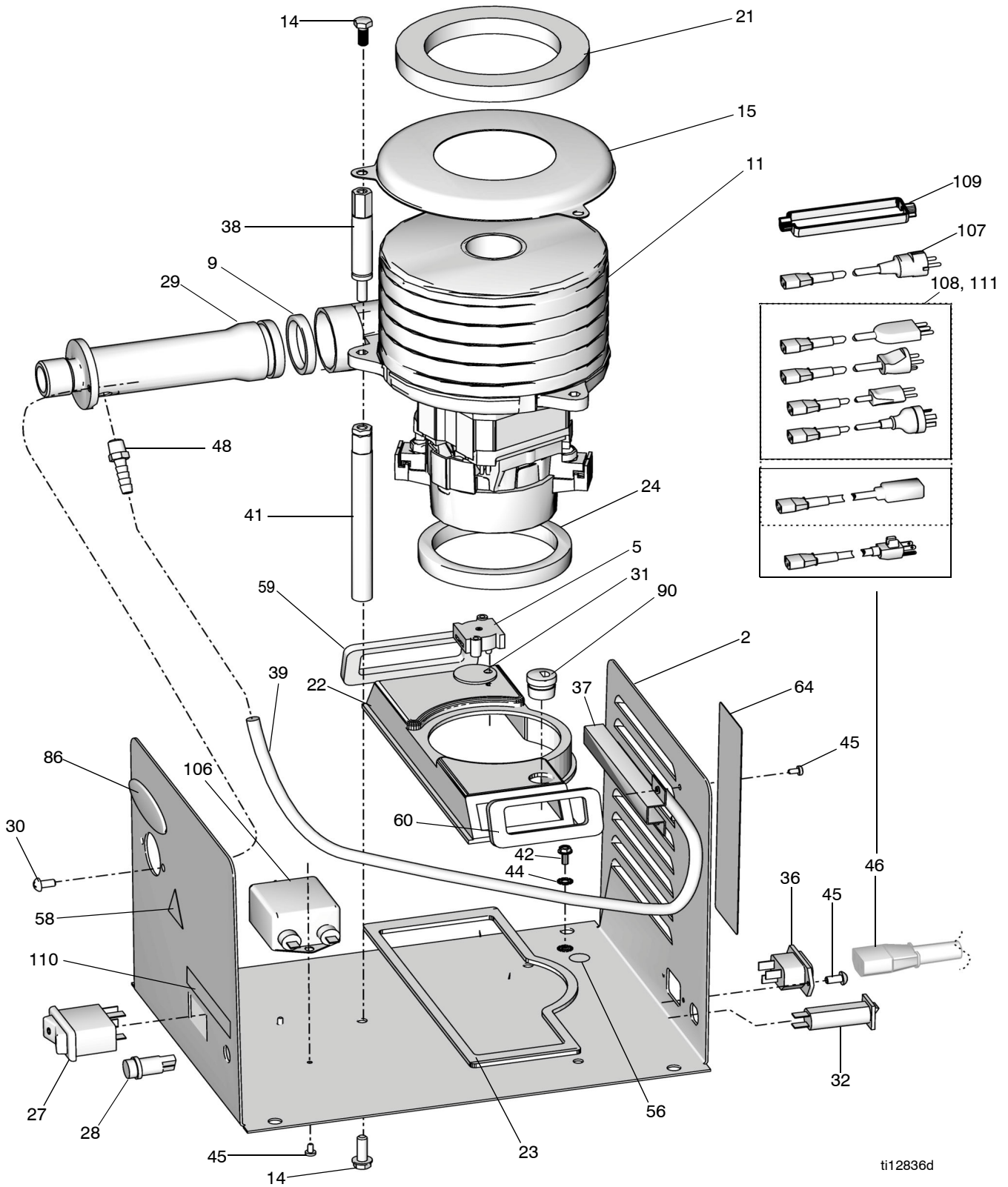



# Parts List

## Models 256847, 256848, 256849, 256851, 256852, 256853

Ref.	Part	Description	Qty.	Ref.	Part	Description	Qty.
2	257066	PLATE, base, turbine, painted	1	41	15X722	SPACER, turbine	3
5	114279	SENSOR, pressure	1	42	111593	SCREW, grounding	1
9	156698	O-RING	1	44	102063	WASHER, lock, ext	1
11+*		TURBINE		45		SCREW, mach, torx pan hd	
	15Y812	FinishPro 7.0, 3-stage, 120V	1		15W998	120V	4
	15Y813	FinishPro 9.0, 4-stage, 120V	1		15W998	240V	6
	15Y814	FinishPro 9.5, 5-stage, 120V	1	46		CORD, power	
	15Y815	FinishPro 7.0, 3-stage, 240V	1		15W126	USA, 6 ft. 15A, 120V	1
	15Y816	FinishPro 9.0, 4-stage, 240V	1		116281	Euro, 2 m, 8A, 240V	1
	15Y817	FinishPro 9.5, 5-stage, 240V	1	48	15Y606	FITTING, barbed	1
14	114670	SCREW, cap, hex hd	6	56	186620	LABEL, ground	1
15	194094	PLATE, turbine	1	58▲	15K616	LABEL, brand, hot surface	1
21		GASKET, turbine		59◆✓	16E351	GASKET, duct, left	1
	15W153	FinishPro 7.0	1	60◆✓	16E353	GASKET, duct, right	1
	15W152	FinishPro 9.0	1	64▲	15W224	LABEL, safety	1
	192788	FinishPro 9.5	1	86	15W640	LABEL, brand, TurboForce	1
22	15W274	DUCT, turbine	1	90	114689	BUSHING, strain relief	1
23◆✓	16P954	GASKET, DUCT	1	106	116168	FILTER, suppression, EMI, 240V	1
24	192845	GASKET, DUCT	1	107	242001	CORDSET, adapter, Europe	1
27	120660	SWITCH, rocker	1	108	287121	CORDSET, adapter, 220V, global, includes 108a through 108d	1
28		LIGHT, indicator		108a		CORDSET, adapter, Italy	1
	114280	120V	1	108b		CORDSET, adapter, Denmark	1
	114286	240V	1	108c		CORDSET, adapter, Switzerland	1
29	16A180	FITTING, outlet	1	109	195551	RETAINER, plug adapter	1
30	114669	SCREW, mach, phillips pan hd	2	110	15X254	SWITCH INDICATOR	1
31	193059	GASKET, sensor	1	111	242005	CORDSET, adapter, Australia	1
32◆✓		CIRCUIT Breaker					
	114403	120V, 15A	1				
	16A348	240V, 10A	1				
36	114064	PLUG, INLET	1				
37	192905	PLATE, deflector	1				
38◆✓		SPACER, turbine					
	15W148	FinishPro 7.0	3				
	15W149	FinishPro 9.0	3				
	15W150	FinishPro 9.5	3				
39	192810	HOSE, air	1				

\* Cleaning Brush Kits 256953 and 256954 are also available.

▲ Extra Danger and Warning labels are available for free.

+ Turbine kit includes items 9, 15, 21, 23, 24, 59 and 60

◆ Gasket/Breaker Kit 15 Amp 24F670 includes items 23, 32, 59, 60

✓ Gasket/Breaker Kit 10 Amp 24F671 includes items 23, 32, 59, 60

# Graco Standard Warranty

Graco warrants all equipment referenced in this document which is manufactured by Graco and bearing its name to be free from defects in material and workmanship on the date of sale to the original purchaser for use. With the exception of any special, extended, or limited warranty published by Graco, Graco will, for a period of twelve months from the date of sale, repair or replace any part of the equipment determined by Graco to be defective. This warranty applies only when the equipment is installed, operated and maintained in accordance with Graco's written recommendations.

This warranty does not cover, and Graco shall not be liable for general wear and tear, or any malfunction, damage or wear caused by faulty installation, misapplication, abrasion, corrosion, inadequate or improper maintenance, negligence, accident, tampering, or substitution of non-Graco component parts. Nor shall Graco be liable for malfunction, damage or wear caused by the incompatibility of Graco equipment with structures, accessories, equipment or materials not supplied by Graco, or the improper design, manufacture, installation, operation or maintenance of structures, accessories, equipment or materials not supplied by Graco.

This warranty is conditioned upon the prepaid return of the equipment claimed to be defective to an authorized Graco distributor for verification of the claimed defect. If the claimed defect is verified, Graco will repair or replace free of charge any defective parts. The equipment will be returned to the original purchaser transportation prepaid. If inspection of the equipment does not disclose any defect in material or workmanship, repairs will be made at a reasonable charge, which charges may include the costs of parts, labor, and transportation.

**THIS WARRANTY IS EXCLUSIVE, AND IS IN LIEU OF ANY OTHER WARRANTIES, EXPRESS OR IMPLIED, INCLUDING BUT NOT LIMITED TO WARRANTY OF MERCHANTABILITY OR WARRANTY OF FITNESS FOR A PARTICULAR PURPOSE.**

Graco's sole obligation and buyer's sole remedy for any breach of warranty shall be as set forth above. The buyer agrees that no other remedy (including, but not limited to, incidental or consequential damages for lost profits, lost sales, injury to person or property, or any other incidental or consequential loss) shall be available. Any action for breach of warranty must be brought within two (2) years of the date of sale.

**GRACO MAKES NO WARRANTY, AND DISCLAIMS ALL IMPLIED WARRANTIES OF MERCHANTABILITY AND FITNESS FOR A PARTICULAR PURPOSE, IN CONNECTION WITH ACCESSORIES, EQUIPMENT, MATERIALS OR COMPONENTS SOLD BUT NOT MANUFACTURED BY GRACO.** These items sold, but not manufactured by Graco (such as electric motors, switches, hose, etc.), are subject to the warranty, if any, of their manufacturer. Graco will provide purchaser with reasonable assistance in making any claim for breach of these warranties.

In no event will Graco be liable for indirect, incidental, special or consequential damages resulting from Graco supplying equipment hereunder, or the furnishing, performance, or use of any products or other goods sold hereto, whether due to a breach of contract, breach of warranty, the negligence of Graco, or otherwise.

## **ADDITIONAL WARRANTY COVERAGE**

Graco does provide extended warranty and wear warranty for products described in the "Graco Contractor Equipment Warranty Program".

## Graco Information

For the latest information about Graco products, visit [www.graco.com](http://www.graco.com).

**TO PLACE AN ORDER**, contact your Graco distributor or call 1-800-690-2894 to identify the nearest distributor.

*All written and visual data contained in this document reflects the latest product information available at the time of publication.  
Graco reserves the right to make changes at any time without notice.*

*For patent information, see [www.graco.com/patents](http://www.graco.com/patents).*

Original instructions. This manual contains English. MM 313406

**Graco Headquarters:** Minneapolis

**International Offices:** Belgium, China, Japan, Korea

**GRACO INC. AND SUBSIDIARIES • P.O. BOX 1441 • MINNEAPOLIS MN 55440-1441 • USA**

**Copyright 2008, Graco Inc. All Graco manufacturing locations are registered to ISO 9001.**

[www.graco.com](http://www.graco.com)

Revised October 2013