

Safety Precautions

This manual contains information that must be read and understood before using the equipment. When you come to an area that has one of the following symbols, pay particular attention and make certain to heed the safeguard.

⚠ WARNING

This symbol indicates a potential hazard which may cause serious injury or loss of life. Important safety information will follow.

⚠ CAUTION

This symbol indicates a potential hazard to you or to the equipment. Important information that tells how to prevent damage to the equipment or how to avoid causes of minor injuries will follow.

NOTE: Notes give important information which should be given special attention.

⚠ WARNING

HAZARD: Injection injury - A high pressure stream produced by this equipment can pierce the skin and underlying tissues, leading to serious injury and possible amputation. See a physician immediately.

DO NOT TREAT AN INJECTION INJURY AS A SIMPLE CUT! Injection can lead to amputation. See a physician immediately.

The maximum operating range of the gun is 3600 PSI/248BAR fluid pressure.

PREVENTION:

- NEVER aim the gun at any part of the body.
- NEVER allow any part of the body to touch the fluid stream. DO NOT allow body to touch a leak in the fluid hose.
- NEVER put your hand in front of the gun. Gloves will not provide protection against an injection injury.
- ALWAYS lock the gun trigger, shut the pump off, and release all pressure before servicing, cleaning the tip or guard, changing tip, or leaving unattended. Pressure will not be released by turning off the motor. The PRIME/SPRAY valve must be turned to PRIME to relieve the pressure. Refer to the PRESSURE RELIEF PRESSURE described in the pump manual.
- ALWAYS keep the tip guard in place while spraying. The tip guard provides some protection but is mainly a warning device.
- ALWAYS remove the spray tip before flushing or cleaning the system.
- The paint hose can develop leaks from wear, kinking and abuse. A leak can inject material into the skin. Inspect the hose before each use.
- NEVER use a spray gun without a trigger lock and trigger guard in place and in good working order.
- All accessories must be rated at or above 3600 PSI/248 BAR. This includes spray tips, guns, extensions, and hose.

NOTE TO PHYSICIAN:

Injection into the skin is a traumatic injury. It is important to treat the injury as soon as possible. DO NOT delay treatment to research toxicity. Toxicity is a concern with some coatings injected directly into the blood stream. Consultation with a plastic surgeon or reconstructive hand surgeon may be advisable.

HAZARD: EXPLOSION OR FIRE - Solvent and paint fumes can explode or ignite. Severe injury and/or property damage can occur.

PREVENTION:

- Provide extensive exhaust and fresh air introduction to keep the air within the spray area free from accumulation of flammable vapors.
- Avoid all ignition sources such as static electric sparks, open flames, pilot lights, and hot objects. Connecting or disconnecting power cords or working light switches can make sparks.
- Do not smoke in spray area.
- Fire extinguisher must be present and in good working order.
- Place paint pump at a minimum of 3 feet (preferably more) into a separate, well ventilated room from the spray object or at least 20 feet from the spray object in a well ventilated area (add more hose if necessary). Flammable vapors are often heavier than air. Floor area must be extremely well ventilated. The paint pump contains arcing parts that emit spark and can ignite vapors.
- The equipment and objects in and around the spray area must be properly grounded to prevent static sparks.
- Use only conductive or grounded high pressure fluid hose. Gun must be grounded through hose connections.
- Power cord must be connected to a grounded circuit.
- Always flush unit into a separate metal container, at low pump pressure, with spray tip removed. Hold gun firmly against side of container to ground container and prevent static sparks.
- Follow the material and solvent manufacturer's warnings and instructions.
- Use extreme caution when using materials with a flashpoint below 70° F (21° C). Flashpoint is the temperature that a fluid can produce enough vapors to ignite.
- Plastic can cause static sparks. Never hang plastic to enclose a spray area. Do not use plastic drop cloths when spraying flammable materials.
- Use lowest possible pressure to flush equipment.

GAS ENGINE (WHERE APPLICABLE)

Always place pump outside of structure in fresh air. Keep all solvents away from the engine exhaust. Never fill fuel tank with a running or hot engine. Hot surface can ignite spilled fuel. Always attach ground wire from pump unit to a grounded object, such as a metal water pipe. Refer to engine owner's manual for complete safety information.

HAZARD: EXPLOSION HAZARD DUE TO INCOMPATIBLE MATERIALS - Will cause severe injury or property damage. This equipment contains aluminum and cannot be used with halogenated hydrocarbon solvents.

PREVENTION:

- Do not use materials containing bleach or chlorine.
- Do not use halogenated hydrocarbon solvents such as mildewcide, methylene chloride and 1,1,1 - trichloroethane. They are not compatible with aluminum.
- Contact your coating supplier about the compatibility of material with aluminum.

HAZARD: HAZARDOUS VAPORS - Paints, solvents, insecticides, and other materials can be harmful if inhaled or come in contact with the body. Vapors can cause severe nausea, fainting, or poisoning.

PREVENTION:

- Use a respirator or mask if vapors can be inhaled. Read all instructions supplied with the mask to be sure it will provide the necessary protection.

- Wear protective eyewear.
- Wear protective clothing as required by coating manufacturer.

HAZARD: GENERAL - This product can cause severe injury or property damage.

PREVENTION:

- Read all instructions and safety precautions before operating equipment.
- Always disconnect the motor from the power supply before working on the equipment.
- Follow all appropriate local, state, and national codes governing ventilation, fire prevention, and operation.
- The United States Government Safety Standards have been adopted under the Occupational Safety and Health Act (OSHA). These standards, particularly part 1910 of the General Standards and part 1926 of the Construction Standards should be consulted.
- Use only manufacturer authorized parts. User assumes all risks and liabilities when using parts that do not meet the minimum specifications and safety devices of the pump manufacturer.
- Before each use, check all hoses for cuts, leaks, abrasion or bulging of cover. Check for damage or movement of couplings. Immediately replace the hose if any of these conditions exist. Never repair a paint hose. Replace it with another grounded high-pressure hose.
- All hoses, swivels, guns, and accessories must be pressure rated at or above 3600PSI/248 BAR.
- Do not spray outdoors on windy days.
- Wear clothing to keep paint of skin and hair.

Installation



Always use a tip safety guard for added protection against injection. Beware that the guard alone will not prevent injection. Never cut off tip guard! Always engage gun trigger lock when the gun is not in use. Before servicing equipment, consult owner's manuals and observe all warnings.

Pressure Relief Procedure



Never attempt to install, change, or clean the tip or tip guard without first performing the "Pressure Relief Procedure."

1. Move the spray unit's ON/OFF switch to the OFF position.
2. Turn the spray unit's pressure control knob counterclockwise to its lowest setting.
3. Hold the metal part of the gun firmly to the side of a metal container to ground the gun and avoid a build up of static electricity.
4. Trigger the gun into the container to remove any pressure that may still be in the hose.
5. Lock the gun by turning the gun trigger lock to the locked position.
6. Turn the spray unit's PRIME/SPRAY valve to the PRIME position.

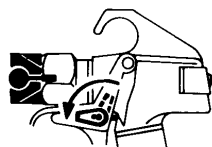
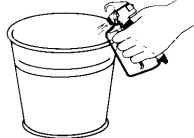

Trigger lock in locked position.

Assembling the Gun and Tip Assembly



Before attaching a gun to a grounded high pressure airless hose, make sure that the airless spray unit is turned off and that fluid pressure has been relieved from the system.

Assembling the Gun

1. Connect a high pressure fluid hose to the material inlet on the gun. Tighten securely with a wrench.
2. With the tip and tip guard off the gun, start the spray unit. Flush the system according to the manufacturer's recommendation. Inspect the unit to make sure that all fittings are secure and that there are no leaks.
3. Perform the "Pressure Relief Procedure" described earlier in this manual.

Assembling the Tip

1. Using the tip handle, insert the tip seal and tip gasket into the back of the tip guard. Press in for final adjustment.
2. Insert the tip into the slot on the tip guard.
3. Thread the tip guard onto the gun. Position the tip guard in the desired spraying position, then tighten securely by hand.

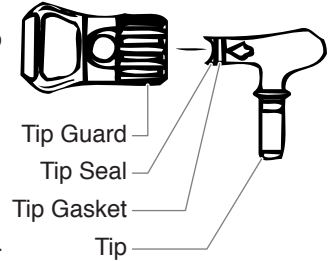

NOTE: The arrow on the tip handle should be pointing in the forward direction for spraying.

Operation

1. Make sure the arrow on the tip handle is pointing in the forward direction for spraying.
2. Start the spray unit.
3. Adjust the fluid pressure on the spray unit until the spray is completely atomized. Always spray at the lowest pressure necessary to get the desired results.

NOTE: The spray tip determines the size of spray pattern and coverage. When more coverage is needed, use a larger tip instead of increasing fluid pressure.

4. To clear a clogged tip:
 - a. Rotate the tip 180° so that the arrow on the tip handle is pointing opposite the spray direction.
 - b. Trigger the gun once so that the pressure can blow the clog out.



Never pull the trigger more than once at time with the tip in the reverse position.

- c. Continue this procedure until the tip is clear of the clog.

Changing a Tip

Tips can be removed and replaced easily without disassembling the gun.



Never attempt to install, change, or clean the tip or tip guard without first performing the "Pressure Relief Procedure."

1. Perform the "Pressure Relief Procedure" described earlier in this manual.
2. Remove the tip from the slot on the tip guard.
3. Insert the new tip into the slot on the tip guard. The arrow on the tip handle should be pointing in the forward direction for spraying.

Removing the Gasket and Seal

1. Remove the tip from the tip guard.
2. Insert the tip handle through the front of the tip guard.
3. Push the gasket and seal out through the back of the tip guard.

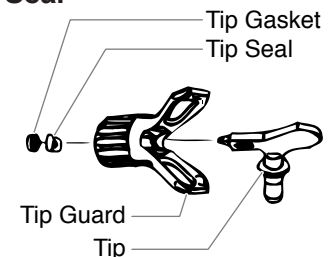

Identifying Tip Sizes

To identify tip sizes, use the following formula. A "517" tip size will be used in this example.

The first digit multiplied by two represents the size of the spray pattern when spraying 12" away from the work surface:

$$5 \times 2 = 10" \text{ spray pattern}$$

The second two digits represent the diameter of the orifice on the tip:

$$17 = .017" \text{ orifice}$$

NOTE: Worn spray tips will adversely affect the spray pattern and result in reduced production, poor finish, and wasted material. Replace worn tips immediately.

Cleanup

Maintaining a clean gun is important to ensure trouble-free operation. Flush the gun after each use and store in a dry location. Do not leave the gun or any of its parts in water or solvents.

⚠ WARNING

Special cleanup instructions for use with flammable solvents:

- Always flush spray gun preferably outside and at least one hose length from spray pump.
- If collecting flushed solvents in a one gallon metal container, place it into an empty five gallon container, then flush solvents.
- Area must be free of flammable vapors.
- Follow all cleanup instructions.

⚠ CAUTION

The pump, hose, and gun should be cleaned thoroughly after daily use. Failure to do so permits material to cake, seriously affecting the performance of the unit.

⚠ WARNING

Always spray at minimum pressure with the gun nozzle tip removed when using mineral spirits or any other solvent to clean the pump, hose, or gun. Static electricity buildup may result in a fire or explosion in the presence of flammable vapors.

⚠ WARNING

Always remove the tip/tip guard, adjust the pressure to its lowest setting, and hold the gun firmly against a metal container while flushing.

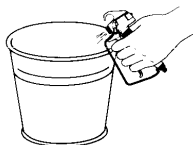

Maintenance

⚠ WARNING

Follow all safety precautions as described in the Safety Precautions section of this manual before proceeding.

Replacing/Serviceing the Seal Assembly

If your spray gun leaks or spits at the tip when you release the trigger, the needle or seat is worn, damaged, or dirty and must be replaced or cleaned. Refer to the Parts List section on the back of this manual for part identification.

⚠ WARNING

Never attempt to perform maintenance on the spray gun without first performing the "Pressure Relief Procedure."

1. Disconnect the spray hose from the gun.
2. Remove the tip and tip guard.
3. With the trigger depressed, remove the diffuser and the diffuser washer from the front of the gun.
4. Remove the lock nut, rear housing, and retractor pins from the rear of the gun head.
5. Remove the seal assembly from the front of the gun head by pushing or gently tapping at the back of the seal assembly.
6. Soak the removed parts in the appropriate solvent and wipe clean.
7. Inspect the parts for wear or damage and use new parts during reassembly of the gun, when necessary.

NOTE: Lubricate all packings and moving parts before reassembly with a lithium-based grease.

8. Install the seal assembly into the front of the gun head.
9. Install the retractor pins into the rear of the gun head. Slide the rear housing onto the retractor pins and secure in position with the lock nut.
10. With the trigger depressed, install the diffuser washer followed by the diffuser into the front of the gun head and tighten securely with a wrench.
11. Perform the "Adjusting the Seal Assembly" procedure described below.

Adjusting the Seal Assembly

⚠ WARNING

Proper adjustment of the seal assembly is essential to ensure positive shut-off when the trigger is released.

1. Tighten the lock nut until the rear housing is flush against the gun head.
2. Unscrew the lock nut 3/4 of a turn.

NOTE: To check the adjustment of the seal assembly:

1. Move the gun trigger lock to the locked position.
2. Pull the trigger.

With the trigger lock engaged, there should be 1/32" of movement between the locknut and the rear housing while pulling the trigger.

Replacing/Removing the Filter

1. Move the gun trigger lock to the unlocked position.
2. Loosen and remove the handle from the gun head.
3. Turning clockwise, unscrew the filter from the gun head.

NOTE: Left-handed threads require turning the filter clockwise to remove.

4. Turning counterclockwise, screw the new or cleaned filter into the gun body.
5. Make sure the handle seal is in position and thread the handle into the gun head until secure.
6. Move the gun trigger lock to the locked position.

Accessories

Part #	Description
611-111	6" Gun Extension
611-121	12" Gun Extension
611-131	18" Gun Extension
611-141	24" Gun Extension
611-630	Gun Extension Swivel Head Assy.
310-354-1	3' Pole Extension
310-654-1	6' Pole Extension
711-600	Gun Extension Swivel Head Assy.
316-505	1/4" x 50' Airless Hose, 3300 PSI
711-612	1/8" Airless Tip Gaskets
310-110	Spray/Roll Accessories Kit
310-950	9" Telescoping Roller Kit
310-955	12" Telescoping Roller Kit

Parts List

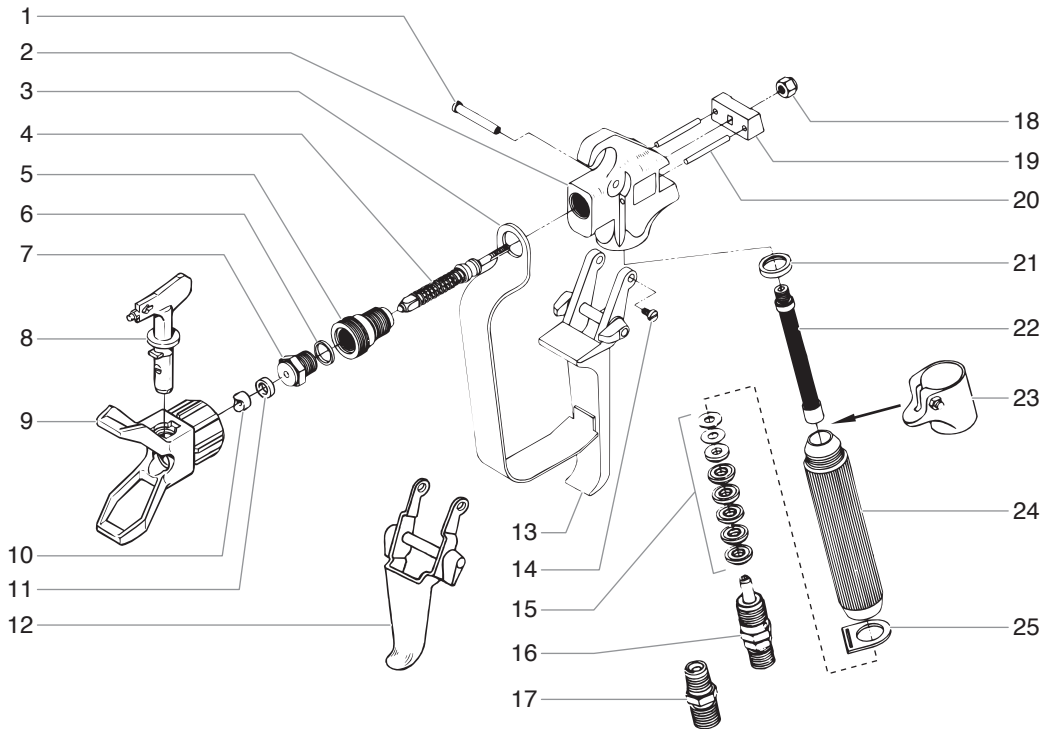

Item	Part #	Description	Quantity	Item	Part #	Description	Quantity
1	581-087	Trigger pin screw	1	16	500-052	Swivel fitting (gun with swivel fitting only) .	1
2	580-005	Gun head.....	1	17	570-008	Straight fitting (gun with straight fitting only).....	1
3	580-023	Trigger guard	1	18	226-001	Lock nut	1
4	580-017	Seal assembly	1	19	580-003	Rear housing	1
5	580-032	Retaining nut housing.....	1	20	580-025	Retractor pin	2
6	520-020	Diffuser washer.....	1	21	560-038	Handle seal.....	1
7	520-018	Diffuser	1	22	500-200-060	Filter.....	1
8	661-517	Tip complete (includes items 10 and 11)	1	23	581-081	Separator (two finger gun only)	1
9	661-012	Tip guard.....	1	24	580-021	Handle (gun with swivel fitting).....	1
10	651-040	Tip seal	1		581-021	Handle (gun with straight fitting)	
11	651-020	Tip gasket	1	25	580-031	Trigger bracket (gun with swivel fitting)	1
12	581-078	Trigger, two finger	1		581-033	Trigger bracket (gun with straight fitting)	
13	580-071	Trigger, four finger (includes items 1 and 14)	1		500-051	Swivel assembly (gun with swivel fitting only, includes items 15 and 16)	1
14	580-019	Trigger screw	1		580-034	Gun repair kit (includes items 4, 6, 7, and 18)	1
15	500-053	Swivel repacking kit (gun with swivel fitting only).....	1				

Limited Warranty

Titan Tool, Inc., ("Titan") warrants that at the time of delivery to the original purchaser for use ("End User"), the equipment covered by this warranty is free from defects in material and workmanship. Titan's obligation under this warranty is limited to replacing or repairing without charge those parts which, to Titan's reasonable satisfaction, are shown to be defective within twelve (12) months after sale to the End User. This warranty applies only when the unit is installed and operated in accordance with the recommendations and instructions of Titan.

This warranty does not apply in the case of damage or wear caused by abrasion, corrosion or misuse, negligence, accident, faulty installation, substitution of non-Titan component parts, or tampering with the unit in a manner to impair normal operation.

Defective parts are to be returned to an authorized Titan sales/service outlet. All transportation charges, including return to the factory, if necessary, are to be borne and prepaid by the End User. Repaired or replaced equipment will be returned to the End User transportation prepaid.

THERE IS NO OTHER EXPRESS WARRANTY. TITAN HEREBY DISCLAIMS ANY AND ALL IMPLIED WARRANTIES INCLUDING, BUT NOT LIMITED TO, THOSE OF MERCHANTABILITY AND FITNESS FOR A PARTICULAR PURPOSE, TO THE EXTENT PERMITTED BY LAW. THE DURATION OF ANY IMPLIED WARRANTIES WHICH CANNOT BE DISCLAIMED IS LIMITED TO THE TIME PERIOD SPECIFIED IN THE EXPRESS WARRANTY. IN NO CASE SHALL TITAN LIABILITY EXCEED THE AMOUNT OF THE PURCHASE PRICE. LIABILITY FOR CONSEQUENTIAL, INCIDENTAL OR SPECIAL DAMAGES UNDER ANY AND ALL WARRANTIES IS EXCLUDED TO THE EXTENT PERMITTED BY LAW.

TITAN MAKES NO WARRANTY AND DISCLAIMS ALL IMPLIED WARRANTIES OF MERCHANTABILITY AND FITNESS FOR A PARTICULAR PURPOSE WITH RESPECT TO ACCESSORIES, EQUIPMENT, MATERIALS OR COMPONENTS SOLD BUT NOT MANUFACTURED BY TITAN. THOSE ITEMS SOLD, BUT NOT MANUFACTURED BY TITAN (SUCH AS GAS ENGINES, SWITCHES, HOSES, ETC.) ARE SUBJECT TO THE WARRANTY, IF ANY, OF THEIR MANUFACTURER. TITAN WILL PROVIDE THE PURCHASER WITH REASONABLE ASSISTANCE IN MAKING ANY CLAIM FOR BREACH OF THESE WARRANTIES.

	United States Sales & Service 1-800-526-5362 Fax 1-800-528-4826	Canadian Branch 1-800-565-8665 Fax 1-905-856-8496	International 1-201-337-1240 Fax 1-201-405-7449
	556 Commerce Street Franklin Lakes, NJ 07417	200 Trowers Road, Unit 7B Woodbridge, L4L 5Z8	556 Commerce Street Franklin Lakes, NJ 07417 USA
	www.titantool.com		www.titan-tools.com
			